



# Kinetix 5700, 5500, 5300, and 5100 Servo Drives Specifications

Kinetix 5700, Kinetix 5500, Kinetix 5300, Kinetix 5100, and ArmorKinetix

Topic	Page
Summary of Changes	2
Servo Drive Compatibility	2
Kinetix 5700 Servo Drives	3
ArmorKinetix System	43
Kinetix 5500 Servo Drives	71
Kinetix 5300 Single-axis EtherNet/IP Servo Drives	91
Kinetix 5100 EtherNet/IP Indexing Servo Drives	110
Common Accessories	135
Motor Overload Protection	146
Additional Resources	147

This document provides catalog numbers and product specifications, including power, performance, environmental, certifications, dimension drawings, and accessories for Allen-Bradley® servo drives.

Use this publication with the Kinetix® Motion Control Selection Guide, publication [KNX-SG001](#), to help make decisions selecting the motion control products that are best suited for your system requirements.

## Summary of Changes

This publication contains the following new or updated information. This list includes substantive updates only and is not intended to reflect all changes.

Topic	Page
Added vibration and shock information for ArmorKinetix® system to the Environmental Specifications table.	69

## Servo Drive Compatibility

Servo Drive Family	Servo Motor Families														
	Kinetix VPL	Kinetix VPC	Kinetix VPF	Kinetix VPH	Kinetix VPS	Kinetix MPL	Kinetix MPM	Kinetix MPF	Kinetix MPS	Kinetix TLP	Kinetix TL	Kinetix TLY	Kinetix RDB	Kinetix MMA	Kinetix HPK
Kinetix 5700	X	X	X	X	X	X	X	X	X	—	—	—	X	X	X
Kinetix 5500	X	—	X	X	X	X	X	X	X	—	—	—	—	—	—
Kinetix 5300	—	—	—	—	—	X	X	X	X	X	X	X	—	—	—
Kinetix 5100	—	—	—	—	—	X	X	X	X	X	X	X	—	—	—
ArmorKinetix	X	—	X	X	X	X	X	X	X	—	—	—	—	—	—

Servo Drive Family	Integrated Linear Thrusters	Integrated Linear Stages		Electric Cylinders			Linear Motors	
	Kinetix LDAT	Kinetix MPAS	Kinetix MPMA	Kinetix VPAR	Kinetix MPAR	Kinetix MPAI	Kinetix LDC	Kinetix LDL
Kinetix 5700	X	X	X	X	X	X	X	—
Kinetix 5500	X (absolute encoder)	X (ballscrew)	X (ballscrew)	X	X	X	—	—
Kinetix 5300	X	X	X	—	X	X	X	X
Kinetix 5100	X (incremental)	X	X	—	X	X	X	X
ArmorKinetix	X	—	—	X	X	—	X	—

# Kinetix 5700 Servo Drives



The Kinetix 5700 drive family helps expand the value of integrated motion on EtherNet/IP™ to large, custom machine-builder applications. Drive modules connect and operate by using ControlLogix® controllers, GuardLogix® controllers, CompactLogix™ controllers, or Compact GuardLogix controllers.

With the Logix Designer application as a single control engine, and one design environment – Studio 5000® – machine builders now have more flexibility to scale, design, and control to help meet their needs. Kinetix 5700 servo drives can help reduce commissioning time and improve machine performance. They offer the simplicity, power, and space savings you need to help get your machine up and running faster.

Kinetix 5700 servo drives are designed for machines with high axis-counts and high-power requirements. Single and dual-axis inverters are available with integrated (drive-based and controller-based) safety functions and hardwired (drive-based) safety functions.

The iTRAK® power supply integrates the iTRAK system with the Kinetix 5700 drive family.

# Kinetix 5700 Drive Module Features and Indicators

## DC-bus Power Supply Features and Indicators

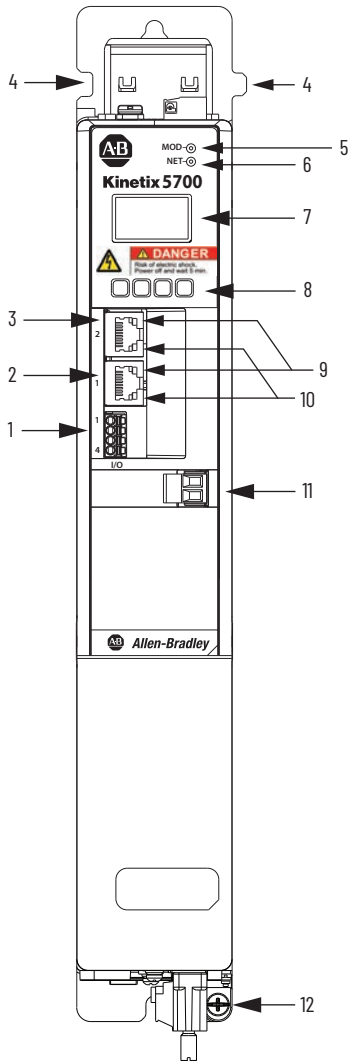

DC-bus Power Supply, Front View  
(2198-P031 module is shown)

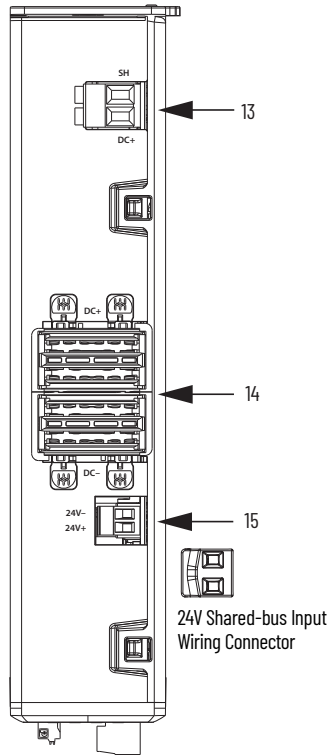

DC-bus Power Supply, Top View  
(2198-P031 module is shown)

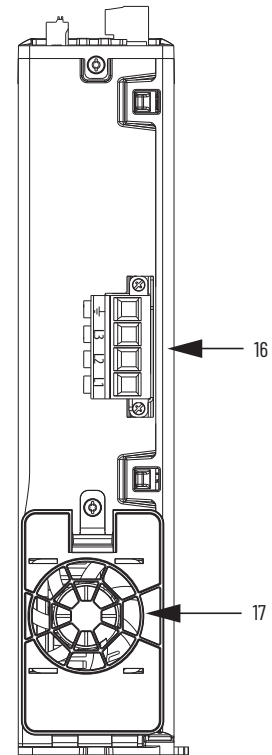

DC-bus Power Supply, Bottom View  
(2198-P031 module is shown)

Item	Description
1	Digital inputs (IOD) connector
2	Ethernet (PORT1) RJ45 connector
3	Ethernet (PORT2) RJ45 connector
4	Zero-stack mounting tab/cutout
5	Module status indicator
6	Network status indicator

Item	Description
7	LCD display
8	Navigation pushbuttons
9	Link speed status indicators
10	Link/Activity status indicators
11	Contactor enable (EN) connector
12	Ground terminal

Item	Description
13	Shunt resistor (RC) connector
14	DC bus (DC) connector
15	24V control input power (CP) connector
16	AC Input power (IPD) connector
17	Cooling fan



### Regenerative Bus Supply Features and Indicators

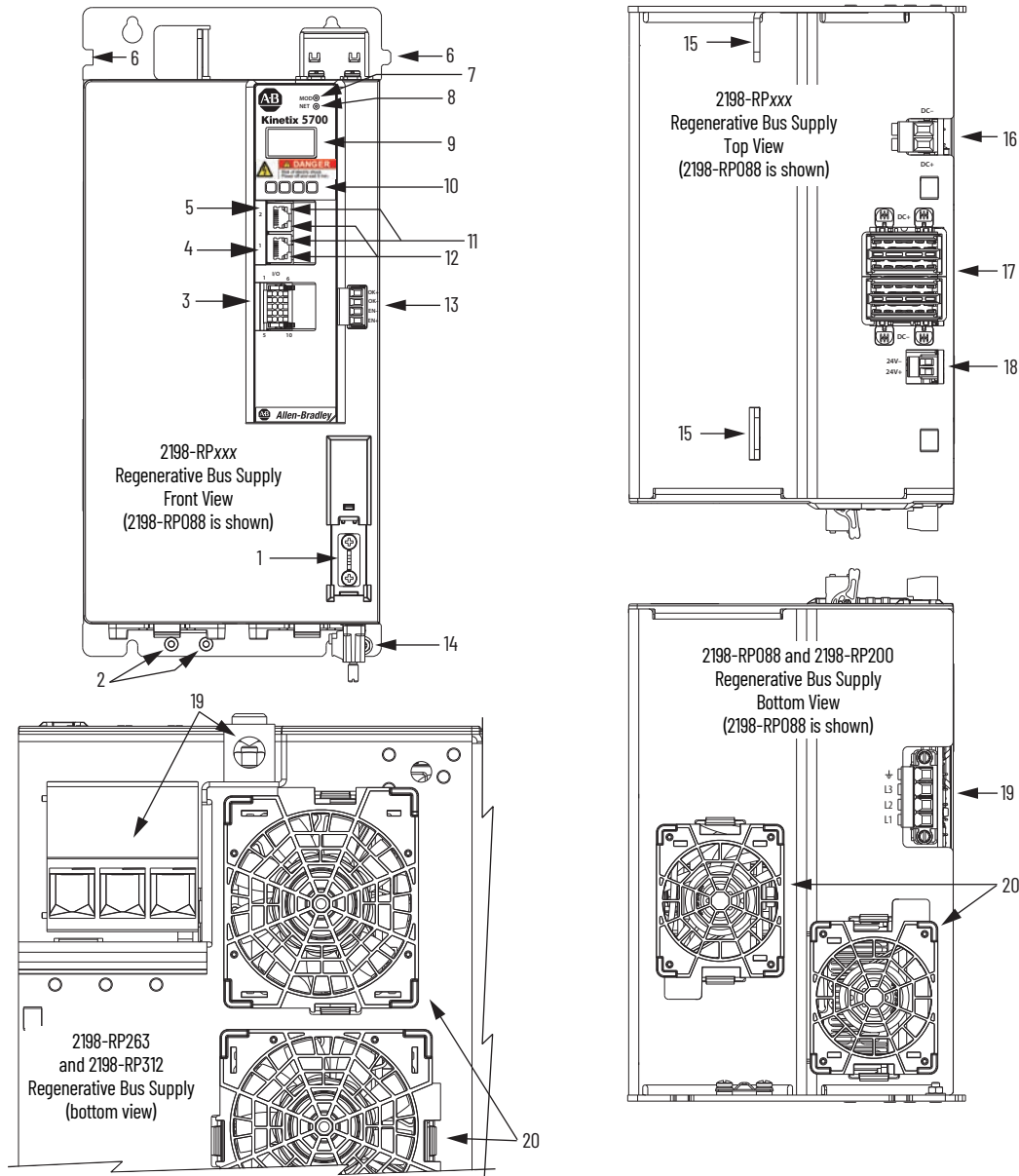

### Regenerative Bus Supply Features and Indicators

Item	Description
1	Ground jumper in operation
2	Ground jumper in storage
3	Digital inputs (IOD) connector
4	Ethernet (PORT1) RJ45 connector
5	Ethernet (PORT2) RJ45 connector
6	Zero-stack mounting tab/cutout
7	Module status indicator

Item	Description
8	Network status indicator
9	LCD display
10	Navigation push buttons
11	Link speed status indicators
12	Link/Activity status indicators
13	Contacter enable (CED) connector
14	Ground lug (partially obscured by input plug)

Item	Description
15	Lifting points
16	Active shunt (RC) connector
17	DC bus (DC) connector
18	24V control input power (CP) connector
19	AC Input power (IPD) connector <sup>(1)</sup>
20	Cooling fans

(1) Connector plug orientation applies to 2198-RP088 and 2198-RP200 modules (2198-RP200 connector size is larger). See adjacent figure for 2198-RP263 and 2198-RP312 connector plug size and orientation.

Dual-axis Inverter Features and Indicators

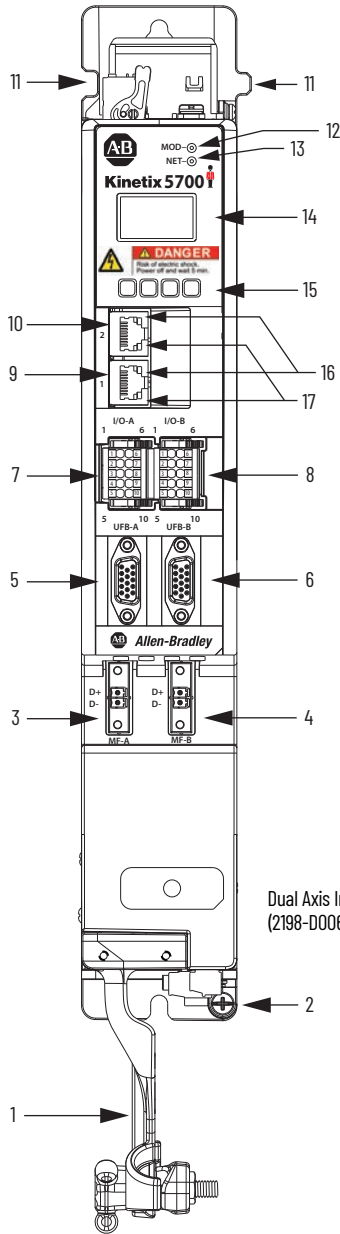

Dual Axis Inverter, Front View  
(2198-D006-ERS4 module is shown)

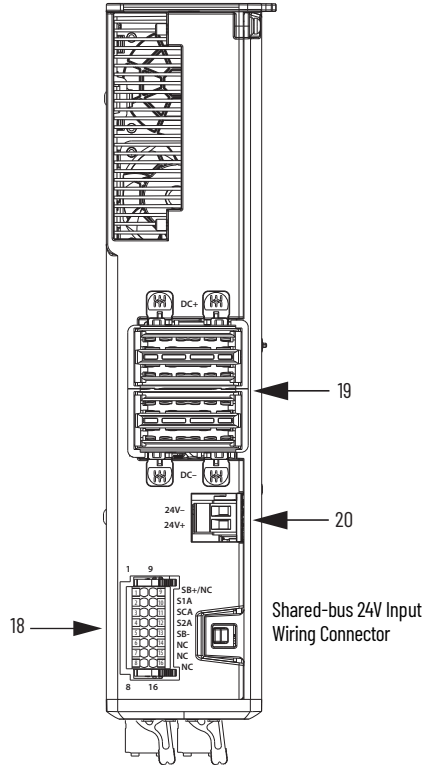

Dual Axis Inverter, Top View  
(2198-D006-ERS4 module is shown)

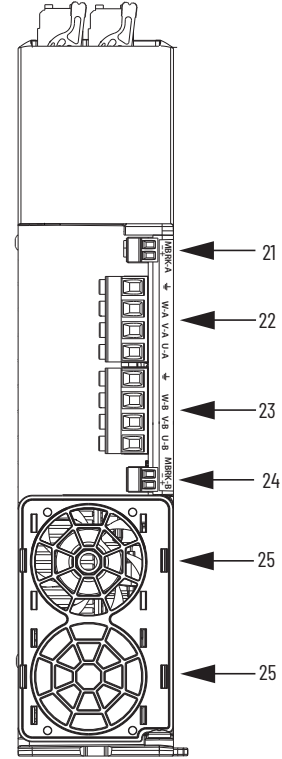

Dual Axis Inverter, Bottom View  
(2198-D006-ERS4 module is shown)

Item	Description
1	Motor cable clamp
2	Ground terminal
3	Motor feedback (MF) connector - A
4	Motor feedback (MF) connector - B
5	Universal feedback (UFB) connector - A
6	Universal feedback (UFB) connector - B
7	Digital inputs (IOD) connector - A
8	Digital inputs (IOD) connector - B
9	Ethernet (PORT1) RJ45 connector

Item	Description
10	Ethernet (PORT2) RJ45 connector
11	Zero-stack mounting tab/cutout
12	Module status indicator
13	Network status indicator
14	LCD display
15	Navigation pushbuttons
16	Link speed status indicators
17	Link/Activity status indicators
18	Safe Torque Off (STO) connector

Item	Description
19	DC bus (DC) connector
20	24V control input power (CP) connector
21	Motor brake (BC) connector - A
22	Motor power (MP) connector - A
23	Motor power (MP) connector - B
24	Motor brake (BC) connector - B
25	Cooling fan

Single-axis Inverter Features and Indicators (catalog numbers 2198-S086-ERSx, 2198-S130-ERSx, and 2198-S160-ERSx)

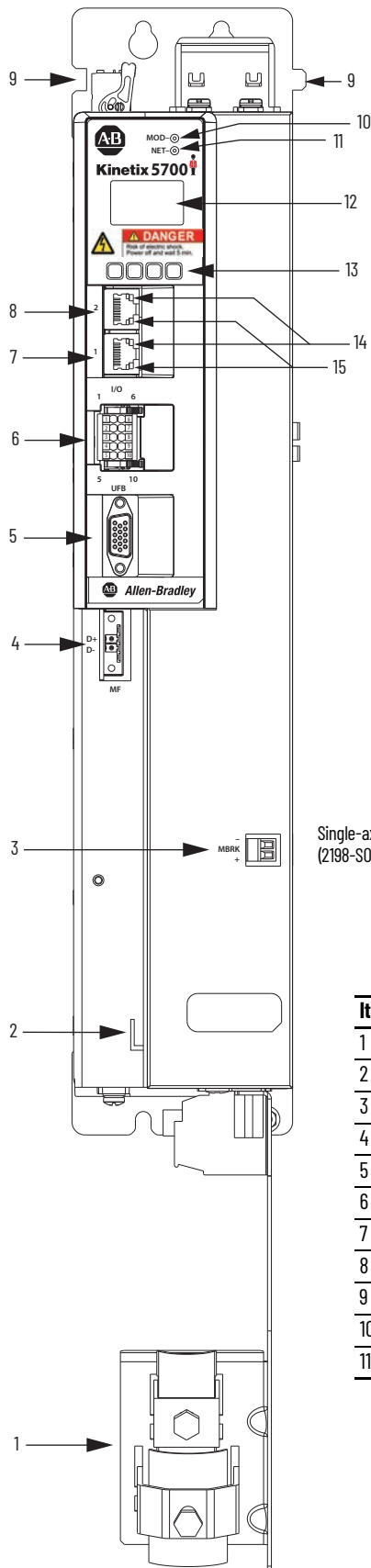

Single-axis Inverter, Front View  
(2198-S086-ERS4 module is shown)

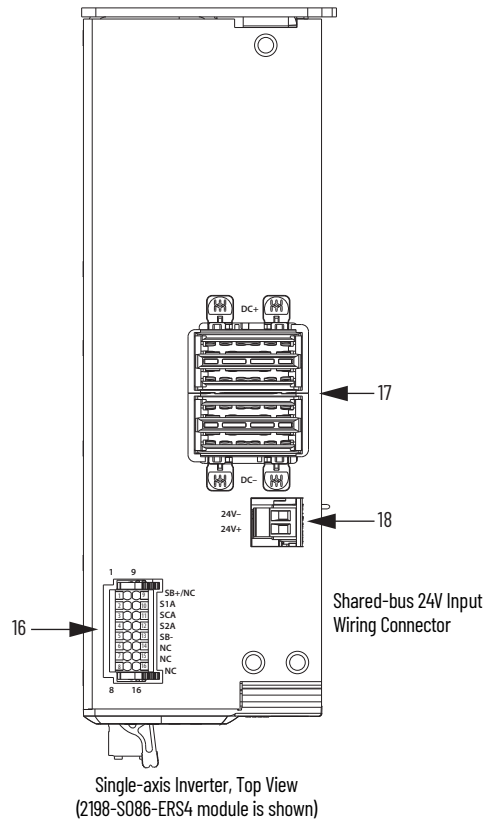

Single-axis Inverter, Top View  
(2198-S086-ERS4 module is shown)

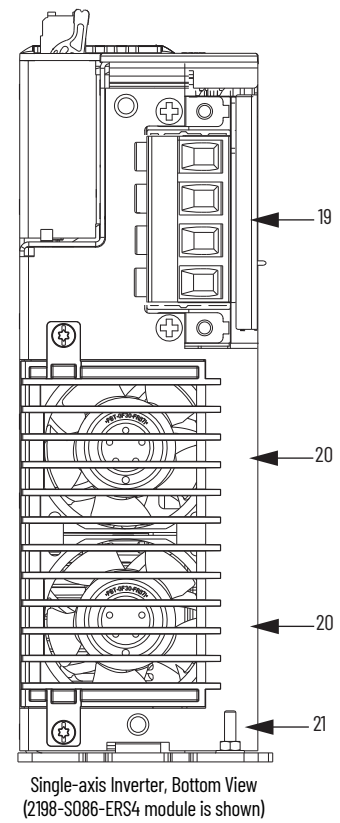

Single-axis Inverter, Bottom View  
(2198-S086-ERS4 module is shown)

Item	Description
1	Motor cable clamp
2	Motor feedback cable tie-wrap bracket
3	Motor brake (BC) connector
4	Motor feedback (MF) connector
5	Universal feedback (UFB) connector
6	Digital inputs (IOD) connector
7	Ethernet (PORT1) RJ45 connector
8	Ethernet (PORT2) RJ45 connector
9	Zero-stack mounting tab/cutout
10	Module status indicator
11	Network status indicator

Item	Description
12	LCD display
13	Navigation pushbuttons
14	Link speed status indicators
15	Link/Activity status indicators
16	Safe Torque Off (STO) connector
17	DC bus (DC) connector
18	24V control input power (CP) connector
19	Motor power (MP) connector
20	Cooling fans
21	Ground terminal

Single-axis Inverter Features and Indicators (catalog numbers 2198-S263-ERSx and 2198-S312-ERSx)

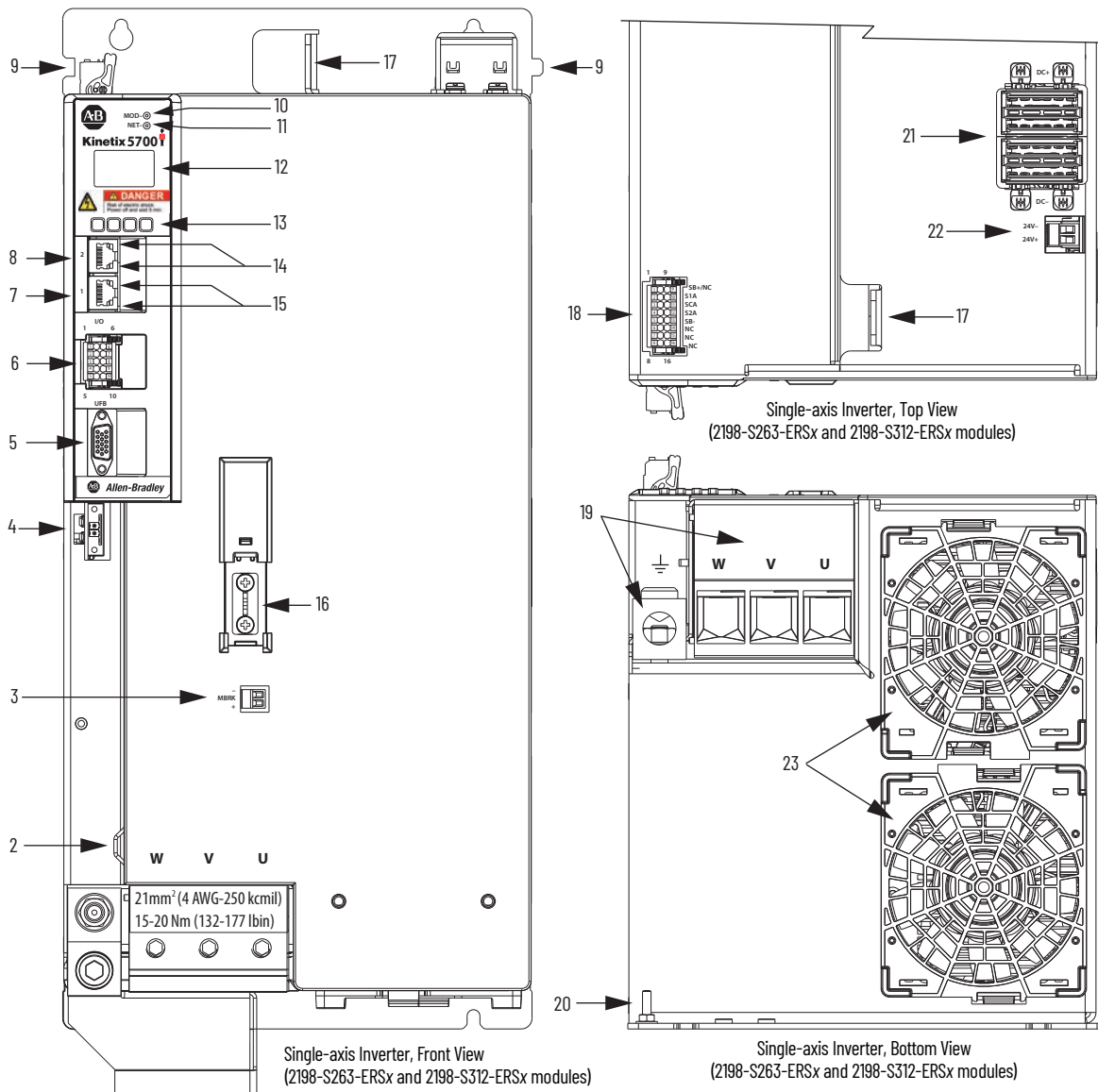

Single-axis Inverter, Front View  
(2198-S263-ERSx and 2198-S312-ERSx modules)

Single-axis Inverter, Top View  
(2198-S263-ERSx and 2198-S312-ERSx modules)

Single-axis Inverter, Bottom View  
(2198-S263-ERSx and 2198-S312-ERSx modules)

Item	Description
1	Motor cable clamp
2	Tie-wrap bracket for feedback cable
3	Motor brake (BC) connector
4	Motor feedback (MF) connector
5	Universal feedback (UFB) connector
6	Digital inputs (IOD) connector
7	Ethernet (PORT1) RJ45 connector
8	Ethernet (PORT2) RJ45 connector
9	Zero-stack mounting tab/cutout
10	Module status indicator
11	Network status indicator
12	LCD display

Item	Description
13	Navigation pushbuttons
14	Link speed status indicators
15	Link/Activity status indicators
16	Ground jumper in operation
17	Safe torque-off (STO) connector
18	Lifting points
19	Motor power (MP) connector
20	Ground terminal
21	DC bus (DC) connector
22	24V control input power (CP) connector
23	Cooling fans (replacement kits available)

iTRAK Power Supply Features and Indicators

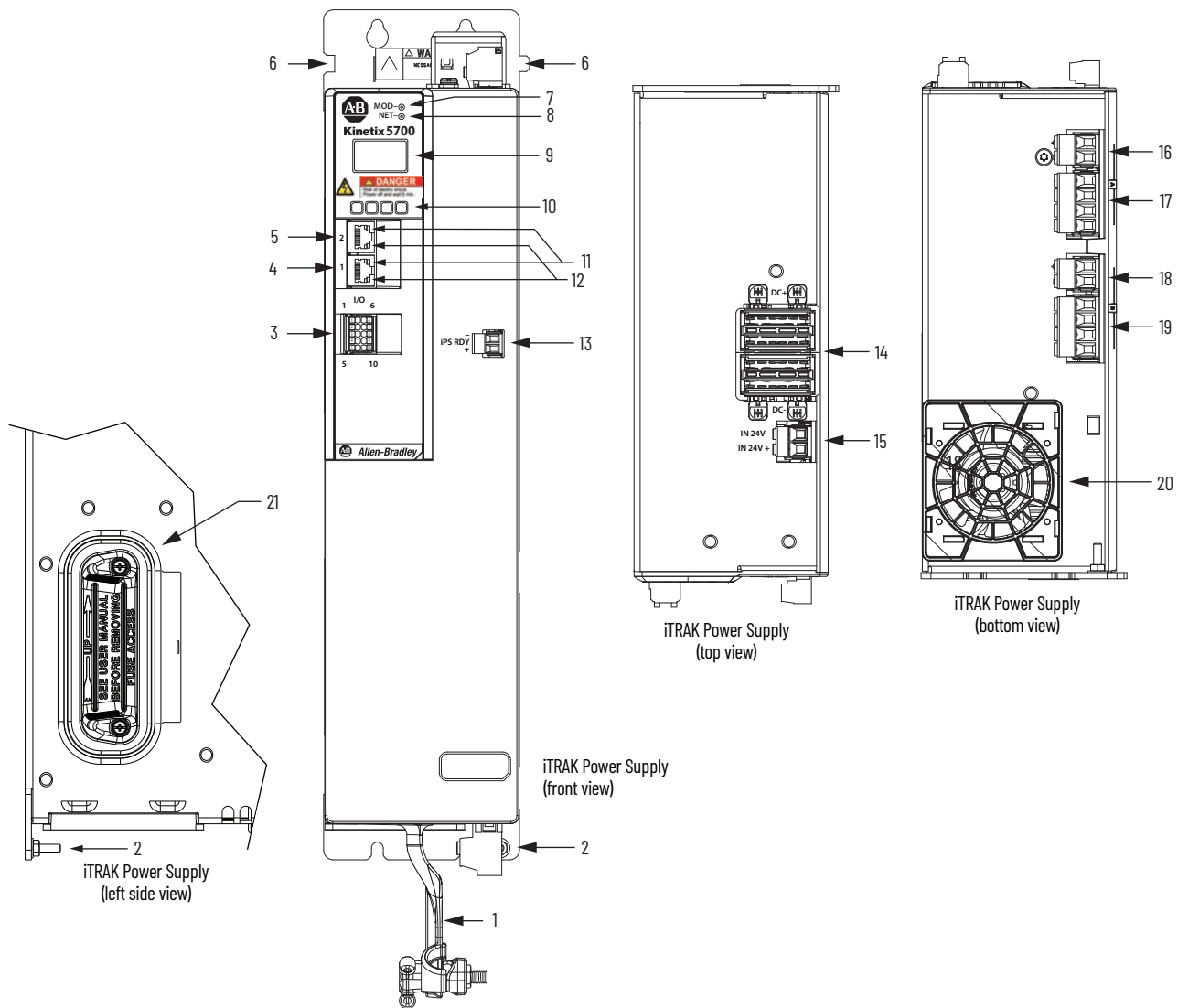

Item	Description
1	Power bus cable clamp
2	Ground lug (partially obscured by output plugs)
3	Digital inputs (IOD) connector
4	Ethernet (PORT1) RJ45 connector
5	Ethernet (PORT2) RJ45 connector
6	Zero-stack mounting tab/cutout
7	Module status indicator

Item	Description
8	Network status indicator
9	LCD display
10	Navigation push buttons
11	Link speed status indicators
12	Link/Activity status indicators
13	iTRAK PS ready (IR) connector
14	DC bus input (DC) connector

Item	Description
15	24V control input power (CP) connector
16	24V control output power (ICP) connector -A
17	DC bus output (IDC) connector - A
18	24V control output power (ICP) connector - B
19	DC bus output (IDC) connector - B
20	Cooling fan
21	Power supply internal fuse

See [Additional Resources](#) on [page 147](#) for the publications that support the iTRAK system.

## Technical Specifications - Kinetix 5700 Drive Modules

### DC-bus Power Supply Specifications

Attribute	2198-P031	2198-P070	2198-P141	2198-P208
AC input voltage	195...528V rms, three-phase (240/480V nom)			
AC input frequency	47...63 Hz			
Main AC input current <sup>(1)</sup> 195...528V (rms) three-phase	11.2A	27.0 A	49.6 A	73.1 A
Max inrush (0...pk)	33.0 A	33.0 A	33.0 A	33.0 A
Peak AC input current 195...528V (rms) three-phase	33.4 A	74.3 A	148.7 A	219.2 A
Line loss ride through	20 ms			
Control power DC input voltage	24V DC $\pm$ 10%			
Control power DC input current <sup>(1) (2)</sup>	0.8 A <sub>DC</sub>		1.9 A <sub>DC</sub>	
Nominal bus output voltage	276...747V DC			
Continuous output current to bus Three-phase	10.5 A <sub>DC</sub>	25.5 A <sub>DC</sub>	46.9 A <sub>DC</sub>	69.2 A <sub>DC</sub>
Peak output current to bus Three-phase	31.6 A <sub>DC</sub>	70.3 A <sub>DC</sub>	140.8 A <sub>DC</sub>	207.6 A <sub>DC</sub>
Peak output current duration <sup>(3)</sup>	1.0 s	1.0 s	1.0 s	0.1 s
Continuous output power to bus Nom (240V rms, three-phase at 1/2 power) Nom (480V rms, three-phase)	3.5 kW 7.0 kW	8.5 kW 17.0 kW	15.5kW 31.0 kW	23.0 kW 46.0 kW
Peak output power to bus Nom (240V rms, three-phase at 1/2 power) Nom (480V rms, three-phase)	10.5 kW 21.0 kW	23.0 kW 46.0 kW	46.5 kW 93.0 kW	69.0 kW 138.0 kW
Bus overvoltage 240V, nom AC input 480V, nom AC input	460V DC 832V DC			
Internal shunt resistance	37.5 $\Omega$		13.5 $\Omega$	
Internal shunt power	75 W		200 W	
Shunt on 240V, nom AC input 480V, nom AC input	400V plus 30V x bus regulator capacity/utilization <sup>(4)</sup> 775V plus 30V x bus regulator capacity/utilization <sup>(4)</sup>			
Shunt off 240V, nom AC input 480V, nom AC input	390V plus 30V x bus regulator capacity/utilization <sup>(4)</sup> 765V plus 30V x bus regulator capacity/utilization <sup>(4)</sup>			
Efficiency	99%			
Internal Capacitance	585 $\mu$ F	780 $\mu$ F	1640 $\mu$ F	2050 $\mu$ F
Capacitive energy absorption	129 J	172 J	362 J	453 J
Short-circuit current rating	200,000 A (rms) symmetrical			

(1) All modules are limited to 1 power cycle per minute.

(2) For current values when motors include a holding brake and additional information, refer to [Control Power Current Specifications](#) on [page 13](#).

(3) Peak output current duration with 10% duty cycle.

(4) The shunt on and shunt off voltages increase during periods of shunting activity to promote sharing of shunt power in multi-axis configurations. Shunt utilization is equivalent to the BusRegulatorCapacity tag in the Logix Designer application.

### Regenerative Bus Supply Specifications

Attribute	2198-RP088	2198-RP200	2198-RP263	2198-RP312
AC input voltage <sup>(1)</sup>	324...506V rms, three-phase (480V nom)			
AC input frequency	47...63 Hz			
Main AC input current <sup>(2)</sup> 324...506V (rms) three-phase	30.0 A	85.0 A	150.0 A	192.0 A
Max inrush (0-pk)	76.0 A	176.0 A	362.0 A	362.0 A
Peak AC input current 324...506V (rms) three-phase	75.0 A	170.0 A	225.0 A	288.9 A

## Regenerative Bus Supply Specifications (Continued)

Attribute	2198-RP088	2198-RP200	2198-RP263	2198-RP312
Line loss ride through	20 ms			
Control power DC input voltage	24V DC $\pm$ 10%			
Control power DC input current <sup>(2)</sup> <sup>(3)</sup>	4.3 A <sub>DC</sub>	5.4 A <sub>DC</sub>	9.1 A <sub>DC</sub>	
Nominal bus output voltage	458...747V DC			
Continuous output current to bus	35.3 A <sub>DC</sub>	100.0 A <sub>DC</sub>	176.4 A <sub>DC</sub>	207.0 A <sub>DC</sub>
Peak output current to bus	88.0 A <sub>DC</sub>	200.0 A <sub>DC</sub>	263.0 A <sub>DC</sub>	312.0 A <sub>DC</sub>
Peak output current duration <sup>(4)</sup>	1.0 s/3.0 s			
Continuous output power to bus Nom (480V rms, three-phase)	24.0 kW	67.0 kW	119.0 kW	140.0 kW
Peak output power to bus Nom (480V rms, three-phase)	60.0 kW	135.8 kW	179.7 kW	211.4 kW
Bus overvoltage - 480V, nom AC input	832V DC			
Internal shunt resistance <sup>(5)</sup>	-		-	
Efficiency	98%			
Internal Capacitance	940 $\mu$ F	2460 $\mu$ F	4510 $\mu$ F	5740 $\mu$ F
Capacitive energy absorption	207 J	542 J	994 J	1265 J
Short-circuit current rating	200,000 A (rms) symmetrical			

(1) Applies when DC-bus voltage regulation is enabled. If DC-bus voltage regulation is not enabled, the input voltage range is 324...528V AC. For more information on these two modes of operation, see the Kinetix 5700 Servo Drives User Manual, publication [2198-UM002](#).

(2) All modules are limited to 1 power cycle per minute.

(3) For current values when motors include a holding brake and additional information, refer to [Control Power Current Specifications](#) on [page 13](#).

(4) 1.0 second peak output current duration with 10% duty cycle. 3.0 second peak output current duration with 5% duty cycle.

(5) The 2198-RPxxx regenerative bus supply has no internal shunt resistor.

## Single-axis Inverter Power Specifications

Attribute	2198-S086-ERS3 2198-S086-ERS4	2198-S130-ERS3 2198-S130-ERS4	2198-S160-ERS3 2198-S160-ERS4	2198-S263-ERS3 2198-S263-ERS4	2198-S312-ERS3 2198-S312-ERS4
Bandwidth <sup>(1)</sup> Velocity loop, max Current loop	400 Hz 1000 Hz				
PWM frequency	4 kHz				
Continuous output current (rms)	43.0 A	65.0 A	85.0 A	150.0 A	192.0 A
Continuous output current (0-pk)	60.8 A	91.9 A	120.2 A	212.1 A	271.5 A
Peak output current (rms)	86.0 A <sup>(2)</sup>	130.0 A <sup>(2)</sup>	160.0 A <sup>(2)</sup>	263.0 A@ 1 and 3 s duration 183.0 A@ 60 s duration	312.0 A@ 1 and 3 s duration 234.0 A@ 60 s duration
Peak output current (0-pk)	121.6 A <sup>(2)</sup>	183.8 A <sup>(2)</sup>	226.2 A <sup>(2)</sup>	371.9 A@ 1 and 3 s duration 258.8 A@ 60 s duration	441.2 A@ 1 and 3 s duration 330.9 A@ 60 s duration
Continuous power out (nom) Nom (240V rms, three-phase at 1/2 power) Nom (480V rms, three-phase)	14.9 kW 29.7 kW	22.5 kW 44.9 kW	30.1 kW 60.1 kW	45.0 kW 90.0 kW	56.0 kW 112.0 kW
DC input current @ 276...747V DC	45.7 A <sub>DC</sub>	69.0 A <sub>DC</sub>	92.3 A <sub>DC</sub>	164.0 A <sub>DC</sub>	207.0 A <sub>DC</sub> <sup>(3)</sup>
Internal Capacitance	560 $\mu$ F	840 $\mu$ F	1120 $\mu$ F	2050 $\mu$ F	2050 $\mu$ F

(1) Bandwidth values vary based on tuning parameters and mechanical components.

(2) Peak current duration ( $T_{PK(max)}$ ) equals 1.0 second.

(3) UL tested to 175.0 A<sub>DC</sub>.

## Dual-axis Inverter Power Specifications

Attribute	Per Axis <sup>(1)</sup>	2198-D006-ERS3 2198-D006-ERS4	2198-D012-ERS3 2198-D012-ERS4	2198-D020-ERS3 2198-D020-ERS4	2198-D032-ERS3 2198-D032-ERS4	2198-D057-ERS3 2198-D057-ERS4
Bandwidth <sup>(2)</sup> Velocity loop, max Current loop		400 Hz 1000 Hz				
PWM frequency		4 kHz				
Continuous output current (rms)	X	2.5 A	5.0 A	8.0 A	13.0 A	23.0 A
Continuous output current (0-pk)	X	3.5 A	7.0 A	11.3 A	18.3 A	32.5 A
Peak output current (rms) <sup>(3)</sup>	X	6.3 A	12.5 A	20.0 A	32.5 A	57.5 A
Peak output current (0-pk) <sup>(3)</sup>	X	8.8 A	17.6 A	28.2 A	45.9 A	81.3 A
Continuous power out (nom) Nom (240V rms, three-phase at 1/2 power) Nom (480V rms, three-phase)	X	0.9 kW 1.7 kW	1.7 kW 3.4 kW	2.8 kW 5.5 kW	4.5 kW 8.9 kW	8.0 kW 15.9 kW
DC input current @ 276...747V DC	X	2.7 A <sub>DC</sub>	5.3 A <sub>DC</sub>	8.5 A <sub>DC</sub>	13.7 A <sub>DC</sub>	24.5 A <sub>DC</sub>
Internal Capacitance		165 µF		330 µF	390 µF	705 µF

(1) These attributes apply to both of the axes in each dual-axis inverter.

(2) Bandwidth values vary based on tuning parameters and mechanical components.

(3) Peak current duration (T<sub>PKmax</sub>) equals 1.0 second.

## iTRAK Power Supply Specifications

Attribute	2198T-W25K-ER
Input voltage	458...747V DC
Continuous output current (per output)	12.5 A
Peak output current	25 A
Continuous power output DC-bus output (low voltage) DC-bus output (high voltage)	4.1 kW 165V DC 330V DC
DC input current <sup>(1)</sup> @ 458V DC in @ 747V DC in	10 A 6.2 A
Internal capacitance	390 µF

(1) Because the iTRAK power supply is a DC-DC converter with a constant output rating, input current varies linearly with input voltage.



## Control Power Current Specifications

Kinetix 5700 servo drives, the accessory modules, and iTRAK power supply have different 24V DC power consumption. Factors to consider when calculating the combined current demand from your 24V DC power supply include the following:

- Catalog number for each drive in the system
- Whether servo motors include the holding brake option
- Whether the system includes capacitor modules or DC-bus conditioner modules
- Whether the system includes 2198T-W25K-ER iTRAK power supplies and the number of iTRAK motor modules supported

### Control Power Current Specifications

Drive Module	Drive Module Cat. No.	24V Current Per Module (non-brake motor) <sup>(1)</sup> A <sub>DC</sub>	24V Inrush Current <sup>(2)</sup> A
DC-bus Power Supplies	2198-P031	0.8	4.0
	2198-P070		
	2198-P141	1.9	
	2198-P208		
Regenerative Bus Supplies	2198-RP088	4.3	4.0
	2198-RP200	5.4	
	2198-RP263	9.1	
	2198-RP312		
Dual-axis Inverters	2198-D006-ERSx	1.4 <sup>(3)</sup>	4.0
	2198-D012-ERSx		
	2198-D020-ERSx	1.7 <sup>(3)</sup>	
	2198-D032-ERSx		
	2198-D057-ERSx		
Single-axis Inverters	2198-S086-ERSx	4.6	4.0
	2198-S130-ERSx		
	2198-S160-ERSx		
	2198-S263-ERSx		
	2198-S312-ERSx		
iTRAK Power Supply <sup>(4)</sup>	2198T-W25K-ER	1.3	2.2
Capacitor Module	2198-CAPMOD-2240	0.1	7.0
Extension Module	2198-CAPMOD-DCBUS-IO	-	-
DC-bus Conditioner Module	2198-DCBUSCOND-RP312	0.1	7.0

(1) For motor-brake current values, see the Kinetix Rotary Motion Specifications Technical Data, publication [KNX-TD001](#).

(2) Inrush current duration is less than 30 ms.

(3) Values are base current per module.

(4) These values represent only the iTRAK power supply. They do not include the iTRAK motor modules that are connected to the iTRAK power supply and also draw current from this 24V control power input. For more information regarding 24V control power requirements, see iTRAK System with TriMax Bearings User Manual, publication [2198T-UM002](#), or iTRAK 5730 System User Manual, publication [2198T-UM003](#).



When the Kinetix 5700 inverter catalog number ends in -ERSx, for example 2198-D057-ERSx, the variable (x) indicates that the inverter (using this example) can be 2198-D057-ERS3 or 2198-D057-ERS4.

## Peak Current Specifications

### Load Duty-cycle Profile Example

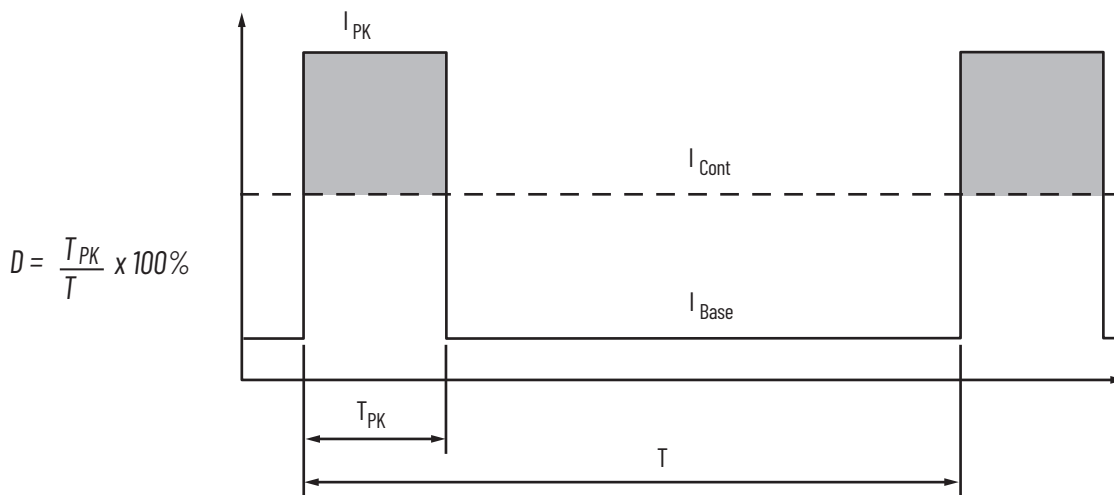

The 2198-S263-ERSx and 2198-S312-ERSx single-axis inverters have overload ratings for 1, 3, and 60 second durations to simplify migration from Kinetix 7000 high-power servo drives.

### Overload Ratings for 2198-S263-ERSx and 2198-S312-ERSx Servo Drives

Drive Cat. No.	1 Second Overload Rating, max		3 Second Overload Rating, max		60 Second Overload Rating, max			
	Current for 1 s	Current for Off Period	Current for 3 s	Current for Off Period	Current for 60 s	Current for Off Period	Current for 3 s	Current for Off Period
2198-S263-ERSx	263 A rms	30 A for ≤9 s	263 A rms	30 A for ≤57 s	183 A rms	98 A for ≤540 s	183 A rms	98 A for ≤540 s
2198-S312-ERSx	312 A rms	30 A for ≤9 s	312 A rms	30 A for ≤57 s	234 A rms	98 A for ≤540 s	234 A rms	98 A for ≤540 s

### Peak Duty Cycle Definition of Terms

Term	Definition (1)
Continuous Current Rating ( $I_{Cont}$ )	The maximum value of current that can be output continuously.
Peak Current Rating ( $I_{PKmax}$ )	The maximum value of peak current that the drive can output. This rating is valid only for overload times less than $T_{PKmax}$ .
Duty Cycle (D)	The ratio of time at peak to the Application Period is defined as: $D = \frac{T_{PK}}{T} \times 100\%$
Time at Peak ( $T_{PK}$ )	The time at peak current ( $I_{PK}$ ) for a given loading profile. Must be less than or equal to $T_{PKmax}$ .
Peak Current ( $I_{PK}$ )	The level of peak current for a given loading profile. $I_{PK}$ must be less than or equal to the Peak Current Rating ( $T_{PKMAX}$ ) of the drive.
Base Current ( $I_{Base}$ )	The level of current between the pulses of peak current for a given loading profile. $I_{Base}$ must be less than or equal to the continuous current rating ( $I_{Cont}$ ) of the drive.
Loading Profile	The loading profile is composed of $I_{PK}$ , $I_{Base}$ , $T_{PK}$ , and D (or T) values and completely specify the operation of the drive in an overload situation. These values are collectively defined as the Loading Profile of the drive.
Application Period (T)	The sum of the times at $I_{PK}$ ( $T_{PK}$ ) and $I_{Base}$ .

(1) All current values are specified as RMS.

Peak Single-axis Inverter Overload ( $T_{PK} < 1.0$  s)

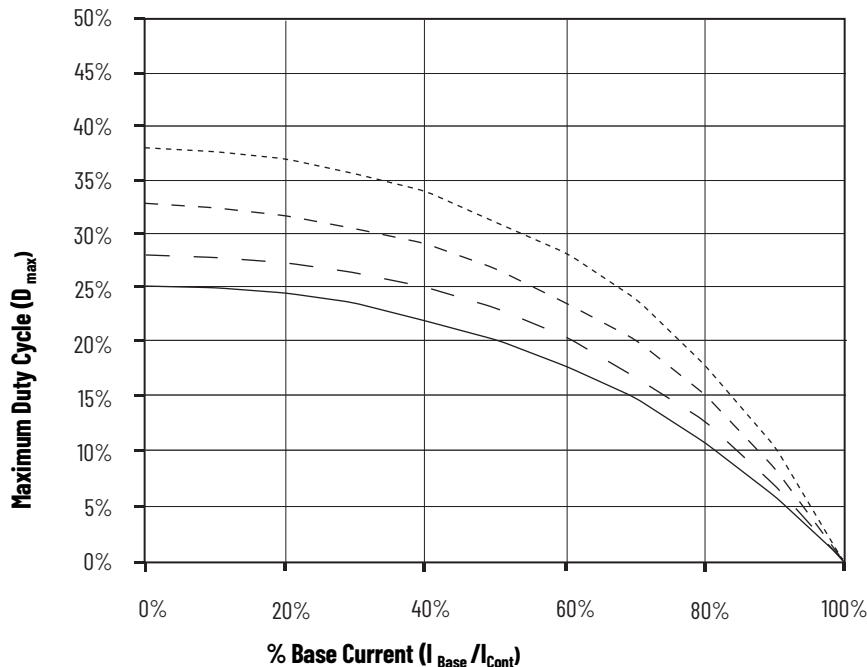

Legend (1)

- $I_{pk} = 162.5\%$   
Applies to 2198-S312-ERSx single-axis inverters.
- $I_{pk} = 175\%$   
Applies to 2198-S263-ERSx single-axis inverters.
- $I_{pk} = 188\%$   
Applies to 2198-S160-ERSx single-axis inverters.
- $I_{pk} = 200\%$   
Applies to 2198-S086-ERSx and 2198-S130-ERSx single-axis inverters.

(1) Base current ( $I_{Base}$ ) and peak current ( $I_{pk}$ ) are a percentage of the continuous drive current rating ( $I_{Cont}$ ).

Peak Dual-axis Inverter and iTRAK Power Supply Overload ( $T_{PK} < 1.0$  s)

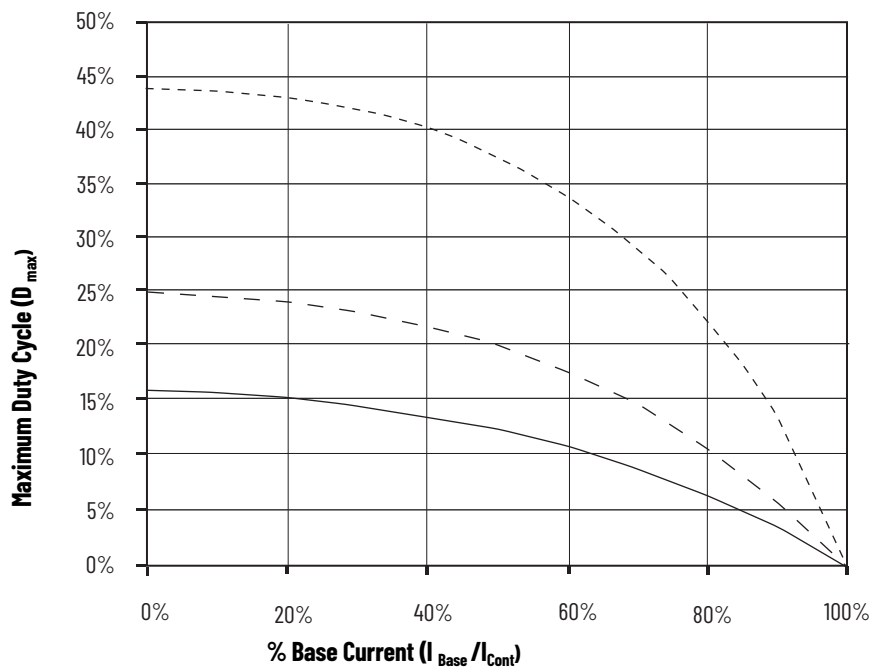

Legend (1)

- $I_{pk} = 150\%$
  - $I_{pk} = 200\%$
  - $I_{pk} = 250\%$
- Applies to all 2198-Dxxx-ERSx dual-axis inverters and 2198T-W25K-ER iTRAK power supply.

(1) Base current ( $I_{Base}$ ) and peak current ( $I_{pk}$ ) are a percentage of the continuous drive current rating ( $I_{Cont}$ ).

## Circuit Breaker/Fuse Specifications

The Kinetix 5700 drives use internal solid-state motor short-circuit protection and, when protected by suitable branch circuit protection, are rated for use on a circuit capable of delivering up to 200,000 A (fuses) and 65,000 A (circuit breakers).

### DC-bus Power Supply UL/CSA Circuit-protection Specifications

DC-bus Power Supply Cat. No.	Input Voltage (three-phase) nom	Bussmann Fuses <sup>(1)</sup> Cat. No.	Miniature CB <sup>(2)</sup> Cat. No.	Motor Protection CB, <sup>(2)</sup> <sup>(3)</sup> Self Protected CMC Cat. No.	Molded Case CB Cat. No.
2198-P031	195...528V AC	LPJ-15SP (15 A)	1489-M3D250	140M-D8E-C25 140MT-D9E-C25	140G-G6C3-C25
2198-P070		LPJ-40SP (40 A)	N/A	140M-F8E-C45	140G-G6C3-C50
2198-P141		LPJ-70SP (70 A)	N/A	N/A	140G-G6C3-C90
2198-P208		LPJ-100SP (100 A)	N/A	N/A	140G-G6C3-D12

- (1) For applications requiring CSA certification, fuses (Bussmann catalog number 170M1760) must be added to the DC link between the two drive clusters when circuit breakers are used for branch circuit protection. The DC bus fuses are not required when AC line fuses are used for branch circuit protection.
- (2) These Bulletin 140M/MT Motor Protection Circuit Breakers, when used as self-protected (Type E) devices, and Bulletin 1489 circuit breakers can be used on only WYE power systems (480Y/277V).
- (3) The AIC ratings of the Bulletin 140M/MT devices can vary. See publication [140-TD005](#) or [140M-TD002](#).

### Regenerative Bus Supply UL/CSA Circuit-protection Specifications

Cat. No.	Input Voltage <sup>(1)</sup> (three-phase) nom	Bussmann Fuses <sup>(2)</sup> Cat. No.	Mersen Fuses Cat. No.	Miniature CB Cat. No.	Molded Case CB Cat. No.
2198-RP088	324...506V AC rms	LPJ-45SP (45 A)	AJT45 (45 A)	-	140G-G6C3-C60
2198-RP200		LPJ-125SP (125 A)	AJT125 (125 A)	-	140G-J6F3-D15
2198-RP263		LPJ-200SP (200 A)	AJT200 (200 A)	-	140G-K6F3-D30
2198-RP312		LPJ-250SP (250 A)	AJT250 (250 A)	-	140G-K6F3-D40

- (1) Applies when DC-bus voltage regulation is enabled. If DC-bus voltage regulation is not enabled, then the input voltage range is 324...528V AC. For more information on these two modes of operation, see the Kinetix 5700 Servo Drives User Manual, publication [2198-UM002](#).
- (2) For applications requiring CSA certification, fuses (Bussmann catalog number 170M1760) must be added to the DC link between the two drive clusters when circuit breakers are used for branch circuit protection. The DC bus fuses are not required when AC line fuses are used for branch circuit protection.

### DC-bus Power Supply IEC (non-UL/CSA) Circuit-protection Specifications

DC-bus Power Supply Cat. No.	Input Voltage (three-phase) nom	DIN gG Fuses Amps, max	Miniature CB Cat. No.	Motor Protection CB Cat. No. <sup>(1)</sup>	Molded Case CB Cat. No.
2198-P031	195...528V AC	16	1489-M3D250	N/A	140M-D8E-C25 140MT-D9E-C25
2198-P070		40	N/A	1492-SPM3D400	140M-F8E-C45
2198-P141		75	N/A	1492-SPM3D630	140MG-H8E-C60
2198-P208		110	N/A	N/A	140MG-H8E-D10

- (1) The AIC ratings of the Bulletin 140M/MT devices can vary. See publication [140-TD005](#) or [140M-TD002](#).

### Regenerative Bus Supply IEC (non-UL/CSA) Circuit-protection Specifications

Regenerative Bus Supply Cat. No.	Input Voltage <sup>(1)</sup> (three-phase) nom	DIN gG Fuses Amps, max	Miniature CB Cat. No.	Motor Protection CB Cat. No.	Molded Case CB Cat. No.
2198-RP088	324...506V AC rms	50	1489-M3C600	1492-SPM3C630	140MG-H8E-C60
2198-RP200		125	-	-	140MG-J8E-D15
2198-RP263		200	-	-	-
2198-RP312		250	-	-	-

- (1) Applies when DC-bus voltage regulation is enabled. If DC-bus voltage regulation is not enabled, then the input voltage range is 324...528V AC. For more information on these two modes of operation, see the Kinetix 5700 Servo Drives User Manual, publication [2198-UM002](#).

## Contactor Specifications

The DC-bus power supply contactor enable relay (CED connector) is rated at 24V DC and 1.0 A, max.

### DC-bus Power Supply Contactor Specifications

DC-bus Power Supply Cat. No.	Contactor <sup>(1)</sup> <sup>(2)</sup> Cat. No.	Intermediate Relay <sup>(3)</sup> Cat. No.
2198-P031	100-C16EJ10	N/A
2198-P070	100-C37EJ10	
2198-P141	100-C72DJ10	700-HB32Z24 (relay) 700-HN153 (socket)
2198-P208	100-C97DJ10	
2198-P208 (2 in parallel)	100-E190KJ11	
2198-P208 (3 in parallel)	100-E305KJ11	

(1) Auxiliary contact configuration (10) is for 1 = N.O. or 0 = N.C. Other configurations are available.

(2) For contactors that are not Bulletin 100-E type, the integrated diode is required with the contactor coil.

(3) These DC-bus power supplies require an additional intermediate relay used with the contactor.

The regenerative power supply contactor enable relay (CED connector) is rated at 24V DC.

### Regenerative Bus Supply Contactor Specifications

Regenerative Bus Supply <sup>(1)</sup> Cat. No.	Contactor <sup>(2)</sup> <sup>(3)</sup> Cat. No.	Intermediate Relay Cat. No.
2198-RP088	100-C43EJ10	N/A
2198-RP200	100-E116KJ11	
2198-RP263	100-E205KJ11	
2198-RP312	100-E285KJ11	

(1) These regenerative bus supplies can require an additional intermediate relay to be used with the contactor. Verify the peak current rating of the main contactor coil.

(2) Auxiliary contact configuration (10) is for 1 N.O. 0 N.C. Other configurations are available.

(3) For contactors that are not Bulletin 100-E type, the integrated diode is required with the contactor coil.

## Power Dissipation Specifications

Use this table to size an enclosure and calculate required ventilation for your Kinetix 5700 drive system.

DC-bus Power Supply Cat. No.	Usage as % of Rated Power Output (watts)				
	20%	40%	60%	80%	100%
2198-P031	97	101	105	109	113
2198-P070	108	119	130	140	151
2198-P141	249	267	286	304	323
2198-P208	265	294	323	352	380
Regenerative Bus Supply Cat. No.					
2198-RP088	253	399	544	690	835
2198-RP200	532	832	1132	1432	1732
2198-RP263	850	1261	1672	2083	2494
2198-RP312	1037	1576	2115	2654	3193
Dual-axis Inverter Cat. No. <sup>(1)</sup>					
2198-D006-ERSx	17	29	41	53	65
2198-D012-ERSx	34	58	82	106	130
2198-D020-ERSx	52	84	116	148	180
2198-D032-ERSx	100	155	210	265	320
2198-D057-ERSx	252	354	456	558	660
Single-axis Inverter Cat. No.					
2198-S086-ERSx	190	255	325	400	475
2198-S130-ERSx	225	340	460	590	725
2198-S160-ERSx	270	420	570	760	950
2198-S263-ERSx	556	759	989	1245	1529
2198-S312-ERSx	610	883	1200	1561	1965
iTRAK Power Supply Cat. No.					
2198T-W25K-ER	206	272	338	404	470
Capacitor Module Cat. No.					
2198-CAPMOD-2240	28	34	42	51	62
2198-CAPMOD-DCBUS-IO	1.1	1.4	1.6	2.1	2.5
DC-bus Conditioner Module Cat. No.					
2198-DCBUSCOND-RP312	1.4	2.1	3.2	4.7	6.7

(1) Values for the dual-axis inverters are based on both axes (each axis dissipates half the rated power output). For example, the 2198-D006-ERSx dual-axis inverter (axis A) with usage of 20% ( $17/2=8.5$  W) and (axis B) with usage of 60% ( $41/2=20.5$  W) dissipates a total of 29 W.

## Weight Specifications

DC-bus Power Supply Cat. No.	Weight, approx kg (lb)
2198-P031	4.33 (9.55)
2198-P070	4.42 (9.74)
2198-P141	6.91 (15.2)
2198-P208	7.04 (15.5)

Dual-axis Inverter Cat. No.	Weight, approx kg (lb)
2198-D006-ERSx	4.16 (9.17)
2198-D012-ERSx	
2198-D020-ERSx	
2198-D032-ERSx	
2198-D057-ERSx	6.76 (14.9)

Regenerative Bus Supply Cat. No.	Weight, approx kg (lb)
2198-RP088	13.61 (30.0)
2198-RP200	38.56 (85.0)
2198-RP263	61.23 (135)
2198-RP312	

Single-axis Inverter Cat. No.	Weight, approx kg (lb)
2198-S086-ERSx	5.21 (11.5)
2198-S130-ERSx	5.44 (12.0)
2198-S160-ERSx	6.80 (15.0)
2198-S263-ERSx	15.88 (35.0)
2198-S312-ERSx	

iTRAK Power Supply Cat. No.	Weight, approx kg (lb)
<b>2198T-W25K-ER</b>	<b>7.60 (16.8)</b>

## Maximum Cable Lengths

Combined motor power cable length for all axes on the same DC bus depends on the Kinetix 5700 system power supply and EMC line filter in use.

- For applications that include the 2198-Pxxx DC-bus power supply and 2198-DBxx-F EMC line filter, the maximum length is up to 400 m (1312 ft)
  - When used with 2198-DBRxx-F EMC line filter, the maximum length is up to 1200 m (3937 ft)
- For applications that include the 2198-RPxxx regenerative bus supply and 2198-DBRxx-F EMC line filter, the maximum length is up to 1200 m (3937 ft)
  - 2198-DBxx-F EMC line filters are not compatible with 2198-RPxxx regenerative bus supplies

Drive-to-motor feedback cables up to 90 m (295 ft) can be used, depending on the feedback type and overall system design. See the Kinetix Rotary and Linear Motion Cable Specifications Technical Data, publication [KNX-TD004](#), for cable specifications.

### Drive-to-Motor Feedback Cable Length

Feedback Type	Cable Length, max <sup>(1)</sup> m (ft)
Single-turn or multi-turn absolute	up to 90 (295)
Incremental <sup>(2)</sup>	up to 30 (98.4)
EnDat	up to 90 (295)

(1) Cable length is not affected by use of the 2198-H2DCK converter kit on the Kinetix 5700 drive.

(2) For motors with incremental feedback, the maximum motor cable length is 30 m (98.4 ft).

**IMPORTANT** For more information on maximum motor cable lengths, see the Kinetix 5700 Servo Drives User Manual, publication [2198-UM002](#).

For iTRAK systems, cables from iTRAK power supply to motor modules up to 30 m (98.4 ft) can be used. See the iTRAK System Technical Data, publication [2198T-TD001](#), for cable specifications.

**IMPORTANT** System performance was tested at these cable lengths. These limitations also apply when meeting CE requirements.

## Dimensions - Kinetix 5700 Servo Drives

These drawings provide mounting dimensions for Kinetix 5700 power supplies, servo drives, and iTRAK power supply. Also included are drawings showing the impact of compatible motor feedback connector kits on the mounting dimensions. Refer to [page 24](#) for dimensions when using these kits.

### DC-bus Power Supply Dimensions

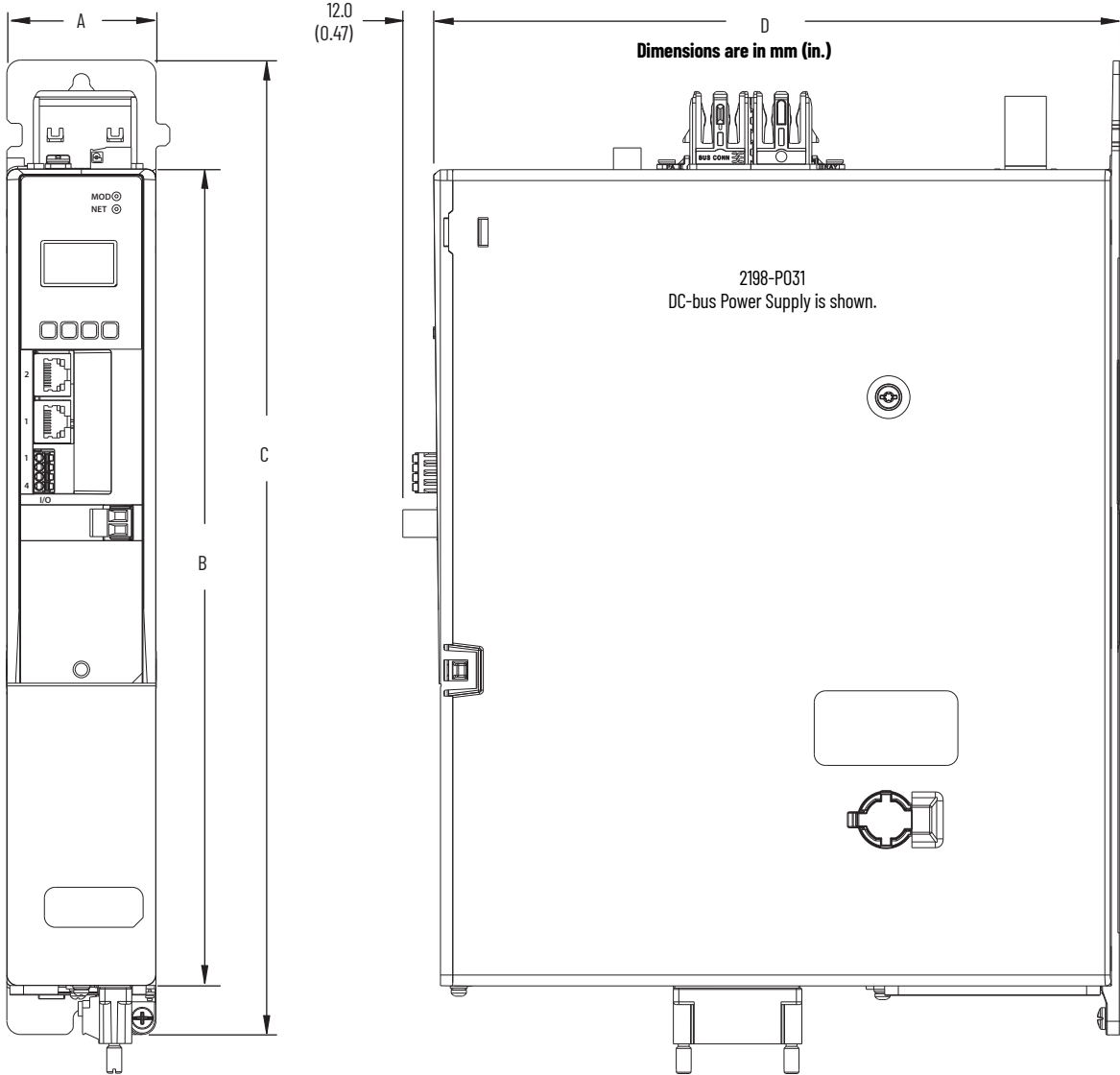

DC-bus Power Supply Cat. No.	A mm (in.)	B mm (in.)	C mm (in.)	D mm (in.)
2198-P031	55 (2.17)	300 (11.81)	358 (14.09)	252 (9.92)
2198-P070				
2198-P141	85 (3.35)	375 (14.76)	433 (17.04)	
2198-P208				



Regenerative Bus Supply Dimensions

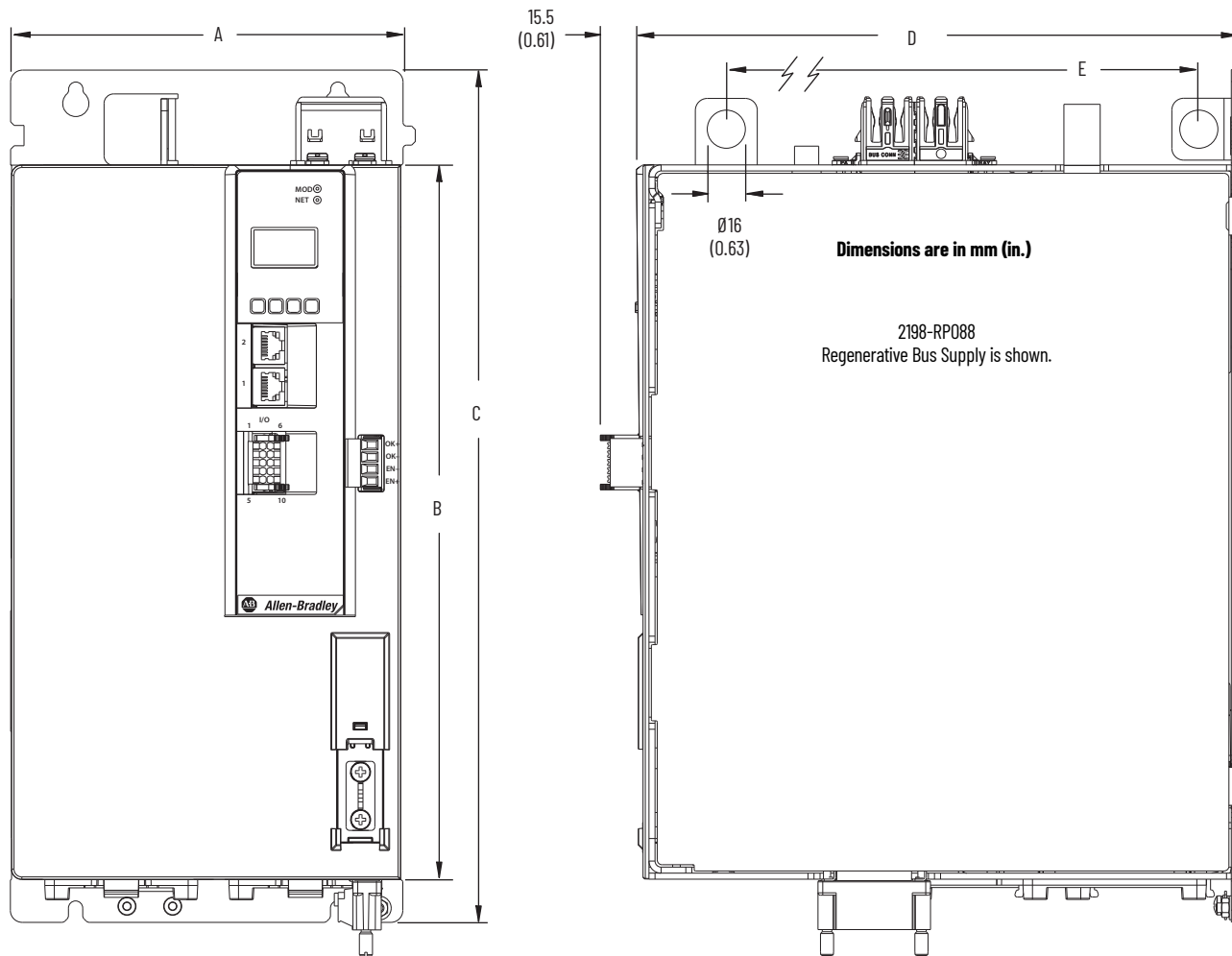

Regenerative Bus Supply Cat. No.	A mm (in.)	B mm (in.)	C mm (in.)	D mm (in.)	E (1) mm (in.)
2198-RP088	165 (6.50)	300 (11.8)	358 (14.1)	252 (9.92)	198 (7.80)
2198-RP200	275 (10.83)	420 (16.54)	478 (18.82)		225 (8.86), max
2198-RP263	440 (17.32)				233 (9.17), max
2198-RP312					

(1) Maximum distance between lift points.

Dual-axis Inverter Dimensions

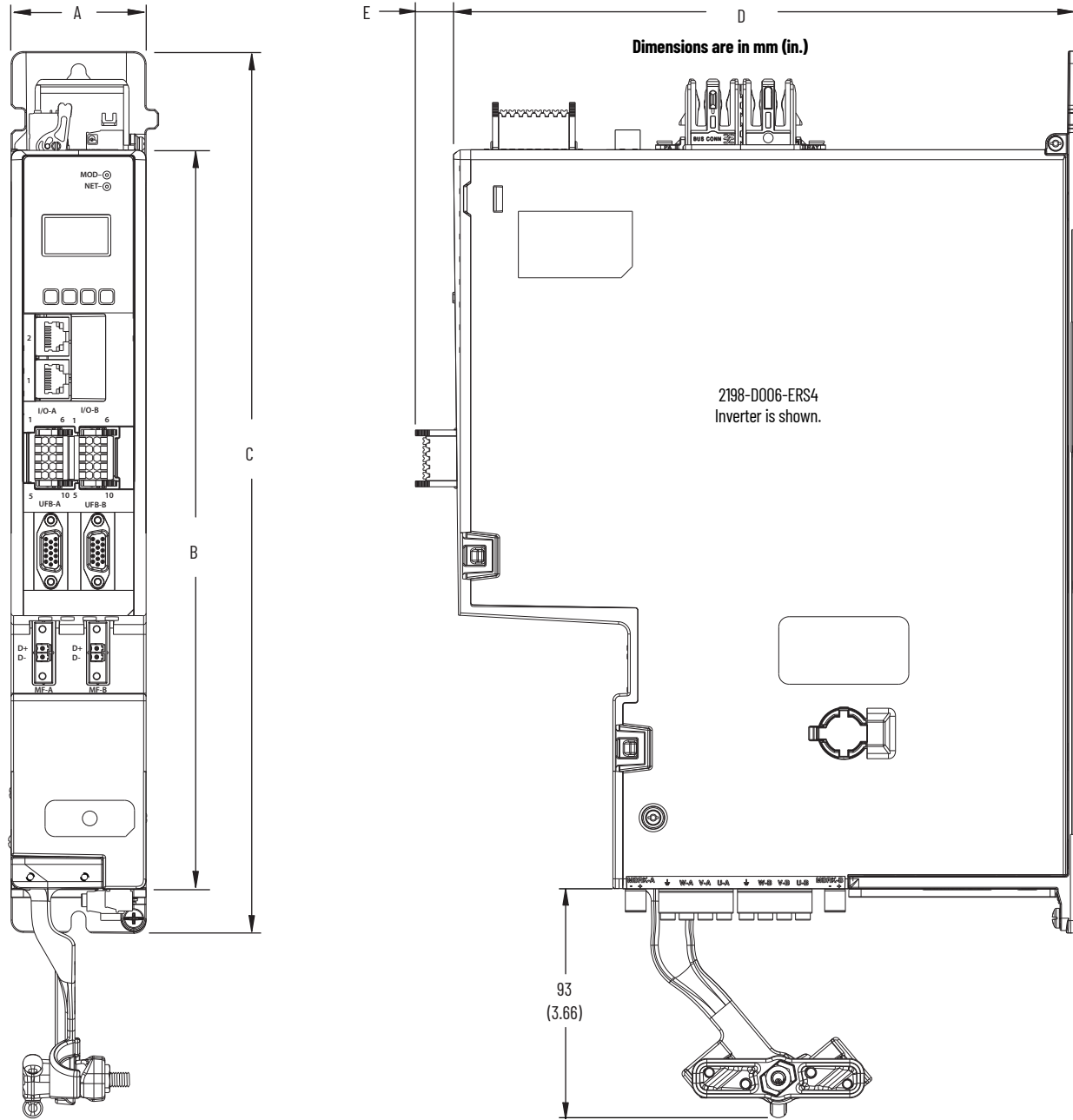

Dual-axis Inverter Cat. No.	A mm (in.)	B mm (in.)	C mm (in.)	D mm (in.)	E mm (in.)
2198-D006-ERSx	55 (2.17)	300 (11.81)	358 (14.09)	252 (9.92)	15.5 (0.61) <sup>(1)</sup>
2198-D012-ERSx					
2198-D020-ERSx					
2198-D032-ERSx					
2198-D057-ERSx	85 (3.35)	375 (14.76)	433 (17.0)		

(1) Applies to 2198-Dxxx-ERS4 and 2198-Dxxx-ERS3 (series B or later) inverters. 2198-Dxxx-ERS3 (series A) inverter value is 12.0 (0.47).

Single-axis Inverter Dimensions

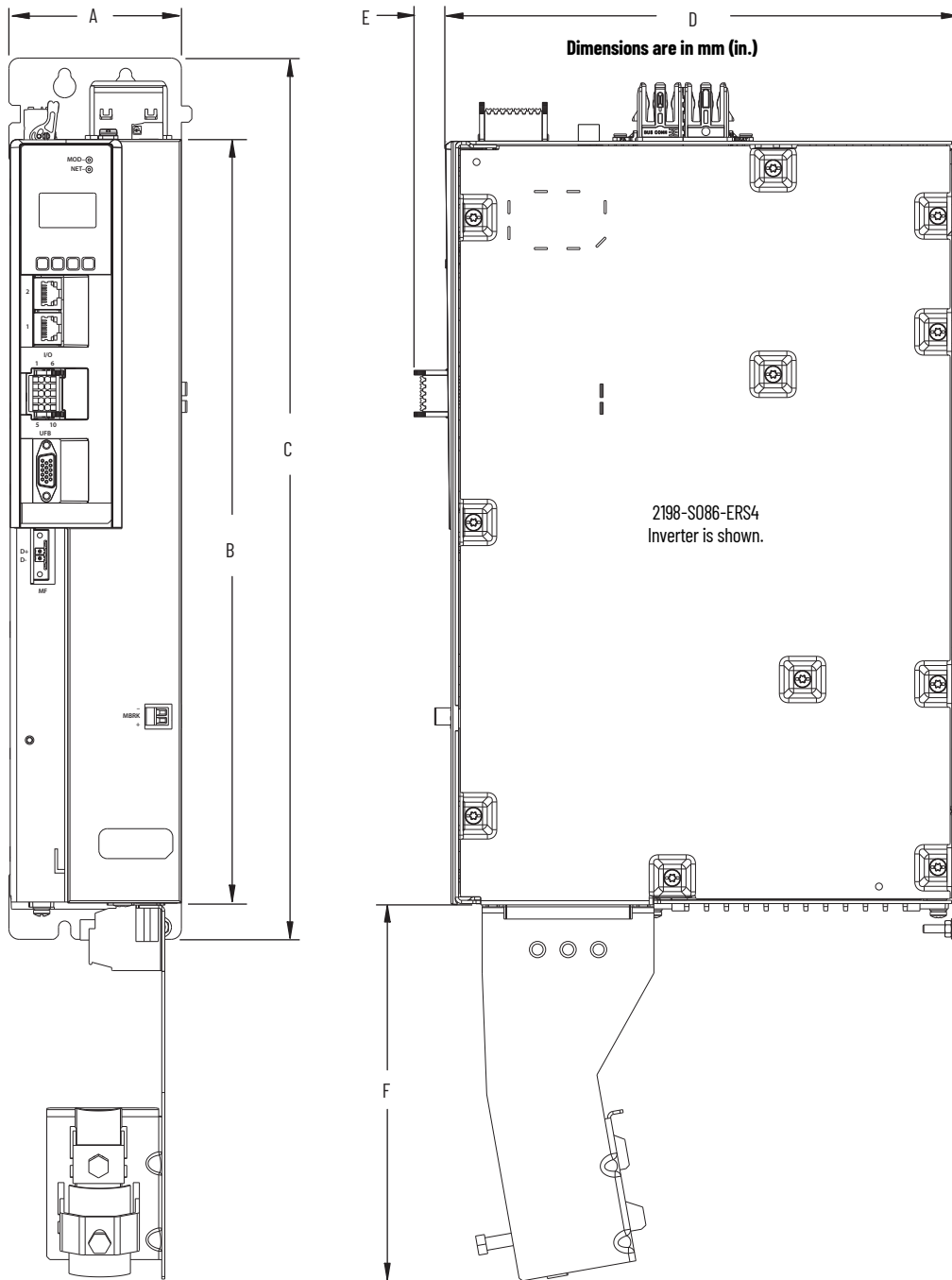

Single-axis Inverter Cat. No.	A mm (in.)	B mm (in.)	C mm (in.)	D mm (in.)	E mm (in.)	F mm (in.)
2198-S086-ERSx	85.0 (3.35)	375 (14.8)	433 (17.0)	252 (9.92)	15.5 (0.61) <sup>(1)</sup>	185 (7.28)
2198-S130-ERSx						
2198-S160-ERSx	100 (3.94)	420 (16.54)	478 (18.82)			
2198-S263-ERSx	220 (8.66)	420 (16.54)	478 (18.82)	15.5 (0.61)	132 (5.19)	
2198-S312-ERSx						

(1) Applies to 2198-Sxxx-ERS4 and 2198-Sxxx-ERS3 (series B or later) inverters. 2198-Sxxx-ERS3 (series A) inverter value is 12.0 (0.47).

The 2198-KITCON-DSL feedback connector kit and 2198-H2DCK feedback converter kit do not affect the mounting dimensions of the drive. No portion of those kits extend out from the front of the drive or below the drive.

**IMPORTANT** The 2198-K57CK-D15M universal feedback kit and 2090-CFBM7DD (drive-end connector) feedback cable extend out from the UFB connector as shown and covers a portion of the other two kits (when they are used), which requires you to install feedback kits in the MF connector first.

These examples show the 2198-K57CK-D15M universal feedback kit and 2090-CFBM7DD feedback cable that is mounted above (covering) the 2198-KITCON-DSL connector kit in the MF connector. You can replace the 2198-KITCON-DSL feedback kit with the 2198-H2DCK converter kit, if needed, without affecting these mounting dimensions.

**Dual-axis Inverter With 2198-K57CK-D15M Universal Feedback Kit**

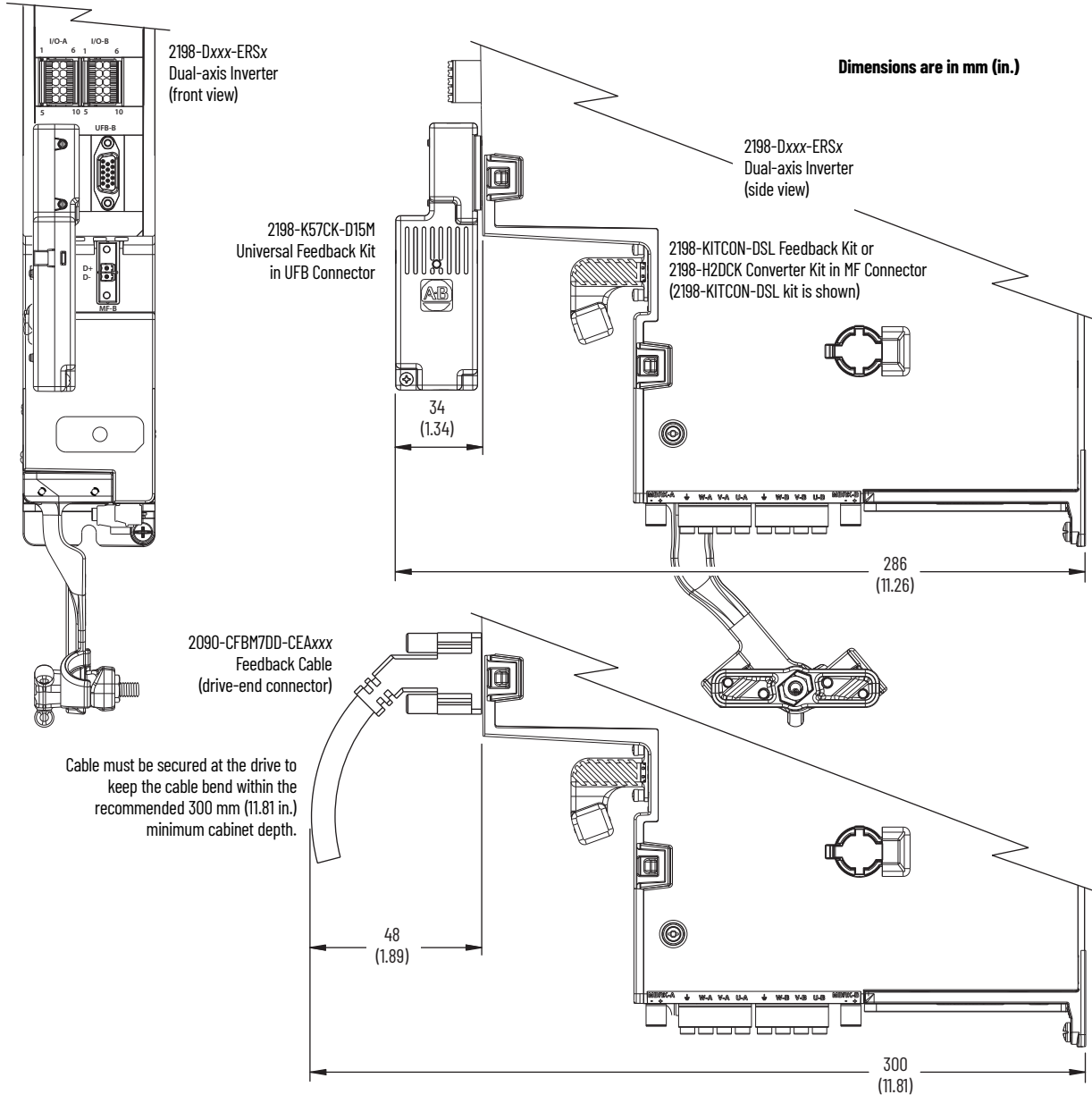

Refer to Universal Feedback Connector Kit on [page 36](#) for motor/actuator compatibility and product dimensions.

Single-axis Inverter With 2198-K57CK-D15M Universal Feedback Kit

Dimensions are in mm (in.)

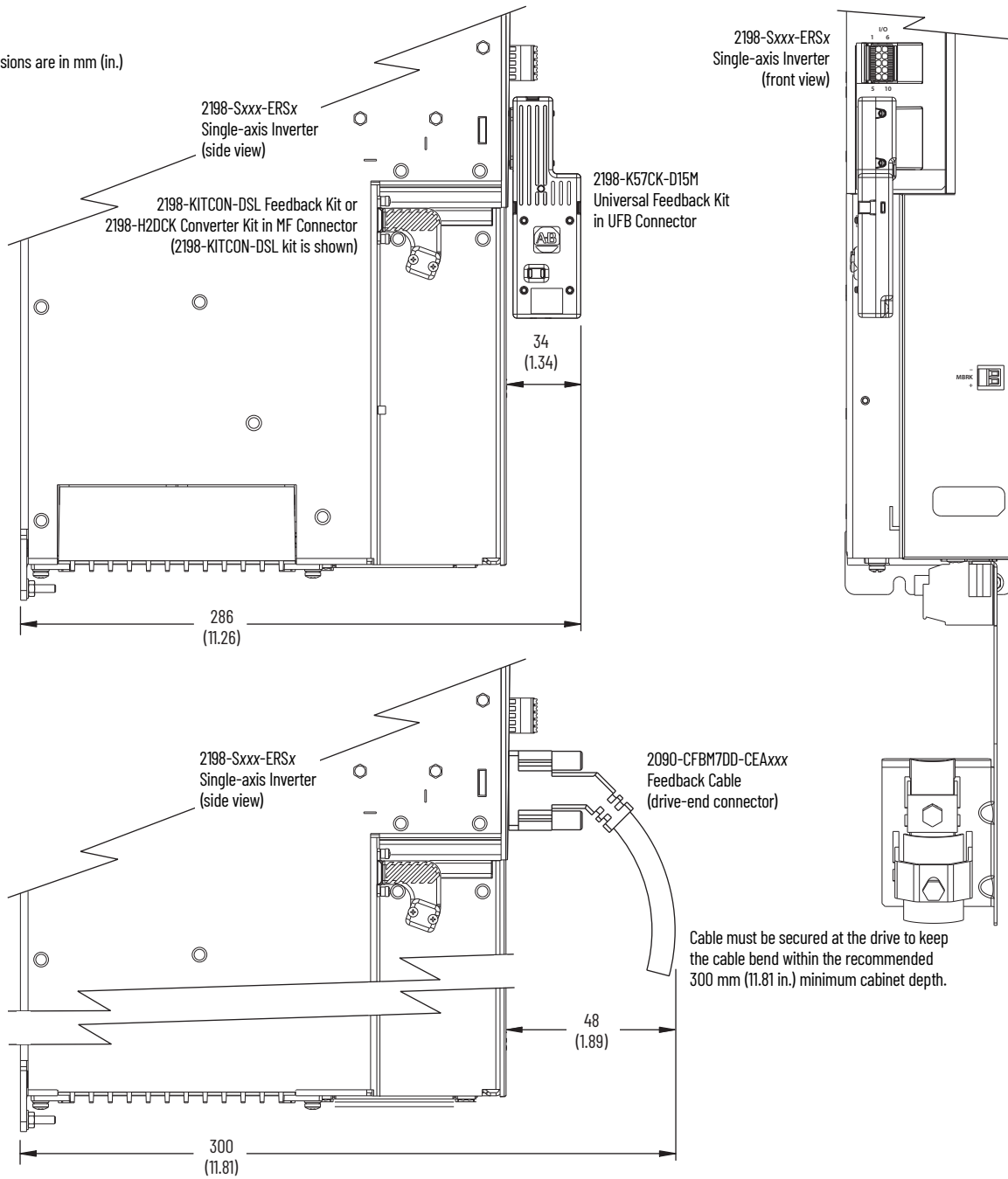

Refer to Hiperface-to-DSL Feedback Converter Kit on [page 37](#) for motor/actuator compatibility and [page 89](#) product dimensions.

iTRAK Power Supply Dimensions

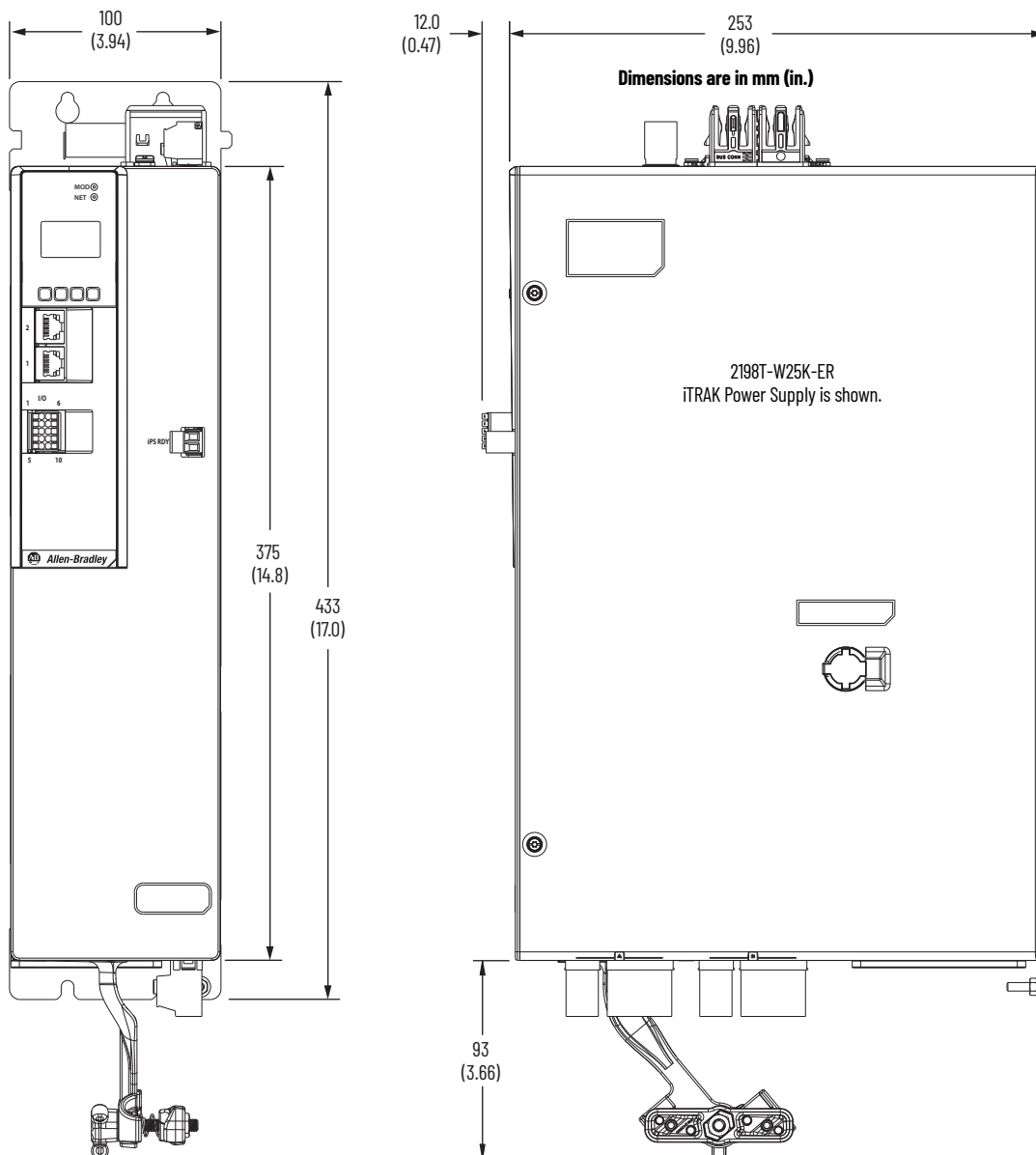

Environmental Specifications - Kinetix 5700 Servo Drives

Attribute	Operational Range	Storage Range (nonoperating)
Ambient temperature	0...50 °C (32...122 °F)	-40...+70 °C (-40...+158 °F)
Relative humidity	5...95% noncondensing	5...95% noncondensing
Protection class (IEC 60529)	IP20	
Degree of pollution (IEC 61800-5-1)	2	
Altitude	<ul style="list-style-type: none"> <li>1500 m (4921 ft) derate 3% per 300 m (984 ft) above 1500 m</li> <li>2000 m (6562 ft) max, with corner-grounded input power</li> <li>3000 m (9843 ft) max, with non corner-grounded input power</li> </ul>	3000 m (9843 ft) during transport
Vibration	5...55 Hz @ 0.35 mm (0.014 in.) double amplitude, continuous displacement; 55...500 Hz @ 2.0 g peak constant acceleration	
Shock	15 g, 11 ms half-sine pulse (3 pulses in each direction of 3 mutually perpendicular directions)	

## Certifications - Kinetix 5700 Servo Drives

### Kinetix 5700 Servo Drives

Agency Certification <sup>(1)</sup>	Standards
cULus <sup>(2)</sup>	UL Listed to U.S. and Canadian safety standards (UL 61800-5-1, File E59272). Solid-state motor overload protection provides dynamic fold-back of motor current when 110% of the motor rating is reached with a peak current limit based on the peak rating of the motor as investigated by UL to comply with UL 61800-5-1, (UL File E59272).
CE	European Union 2004/108/EC EMC Directive compliant with IEC 61800-3:2004 + A1:2012: Adjustable Speed Electrical Power Drive Systems - Part 3; EMC Product Standard including specific test methods. European Union 2006/95/EC Low Voltage Directive compliant with IEC 61800-5-1:2007 - Adjustable speed electrical power drive systems.
Functional Safety	TÜV Certified for Functional Safety: up to SIL CL3, according to IEC 61800-5-2, IEC 61508, and IEC 62061; up to Performance Level PLe and Category 3, according to ISO 13849-1; when used as described in the Kinetix 5700 Servo Drives User Manual, publication <a href="#">2198-UM002</a> or the Kinetix 5700 Safe Monitor Functions Safety Reference Manual, publication <a href="#">2198-RM001</a> .
RCM	Australian Radiocommunications Act, compliant with: <ul style="list-style-type: none"> <li>• Radiocommunications Act: 1992 (including Amendments up to 2017)</li> <li>• Radiocommunications (Electromagnetic Compatibility) Standard: 2017</li> <li>• Radiocommunications Labeling ((Compliance Labelling - Incidental Emissions) Notice: 2017</li> </ul>
KC	Korean Registration of Broadcasting and Communications Equipment, compliant with: <ul style="list-style-type: none"> <li>• Article 58-2 of Radio Waves Act, Clause 3</li> <li>• Registration number: KCC-REM-RAA-2198</li> </ul>
ODVA	<ul style="list-style-type: none"> <li>• EtherNet/IP conformance tested</li> <li>• CIP Security™ conformance tested</li> </ul>
OSHA	Maximum audible noise from the servo drive system complies with OSHA standard 3074, Hearing Conservation (<85 dBA).
Ecodesign	IE2 efficiency class per Ecodesign regulation EU 2019/1781 <sup>(3)</sup>

(1) See [rok.auto/certifications](#) for declarations of conformity, certificates, and other certification details.

(2) UL has not evaluated the Safe Torque Off options in these products.

(3) Products with multiple outputs, such as the 2198-Dxxx-ERSx, are out of scope of the regulation.

### Kinetix 5700 iTRAK Power Supply

Agency Certification <sup>(1)</sup>	Standards
cULus	UL Listed to U.S. and Canadian safety standards (UL 61800-5-1, File E59272 and CSA C22.2 No 274-13).
CE	European Union 2004/108/EC EMC Directive compliant with IEC 61800-3:2004 + A1:2012: Adjustable Speed Electrical Power Drive Systems - Part 3; EMC Product Standard including specific test methods. European Union 2006/95/EC Low Voltage Directive compliant with IEC 61800-5-1:2007 - Adjustable speed electrical power drive systems.
RCM	Australian Radiocommunications Act, compliant with: <ul style="list-style-type: none"> <li>• Radiocommunications Act: 1992</li> <li>• Radiocommunications (Electromagnetic Compatibility) Standard: 2008</li> <li>• Radiocommunications Labeling (Electromagnetic Compatibility) Notice: 2008</li> </ul>
KC	Korean Registration of Broadcasting and Communications Equipment, compliant with: <ul style="list-style-type: none"> <li>• Article 58-2 of Radio Waves Act, Clause 3</li> <li>• Registration number: KCC-REM-RAA-2198</li> </ul>
OSHA	Maximum audible noise from the servo drive system complies with OSHA standard 3074, Hearing Conservation (<85 dBA).

(1) See [rok.auto/certifications](#) for declarations of conformity, certificates, and other certification details.

## Accessories - Kinetix 5700 Servo Drives

Kinetix 5700 drive accessories include the accessory modules, passive shunt modules, the encoder output module, line reactors, AC line filters, feedback connector kits, the system mounting toolkit, and shared-bus connector kits.

### Accessory Modules

The 2198-CAPMOD-2240 capacitor module, 2198-CAPMOD-DCBUS-IO extension module, and 2198-DCBUSCOND-RP312 DC-bus conditioner module are referred to as Kinetix 5700 accessory modules.

Accessory Module <sup>(1)</sup> Cat. No.	Description
2198-CAPMOD-2240 capacitor modules are used:	<ul style="list-style-type: none"> <li>For energy storage and to extend the DC-bus voltage to another inverter cluster</li> <li>As connection points for an external active shunt module</li> <li>In systems with external DC-bus current of up to 104 A, however, can parallel with itself or with another accessory module for up to 208 A.</li> </ul>
2198-CAPMOD-DCBUS-IO extension modules are used:	<ul style="list-style-type: none"> <li>With another accessory module when the external DC-bus current is &gt;104 A, up to a maximum of 208 A</li> <li>To extend the DC-bus voltage to another inverter cluster</li> </ul>
2198-DCBUSCOND-RP312 DC-bus conditioner modules are used:	<ul style="list-style-type: none"> <li>To decrease the voltage stress on isolation components in inverter systems with long cable lengths and other use cases</li> <li>To extend the DC-bus voltage to another inverter cluster</li> <li>In systems with external DC-bus current of up to 104 A, however, can parallel with itself or with another accessory module for up to 208 A.</li> </ul>

(1) Accessory modules can be used in any Kinetix 5700 drive system configurations with DC-bus power supplies, regenerative bus supplies, and 8720MC-RPS power supplies.

### Capacitor Module and DC-bus Conditioner Module Features and Indicators

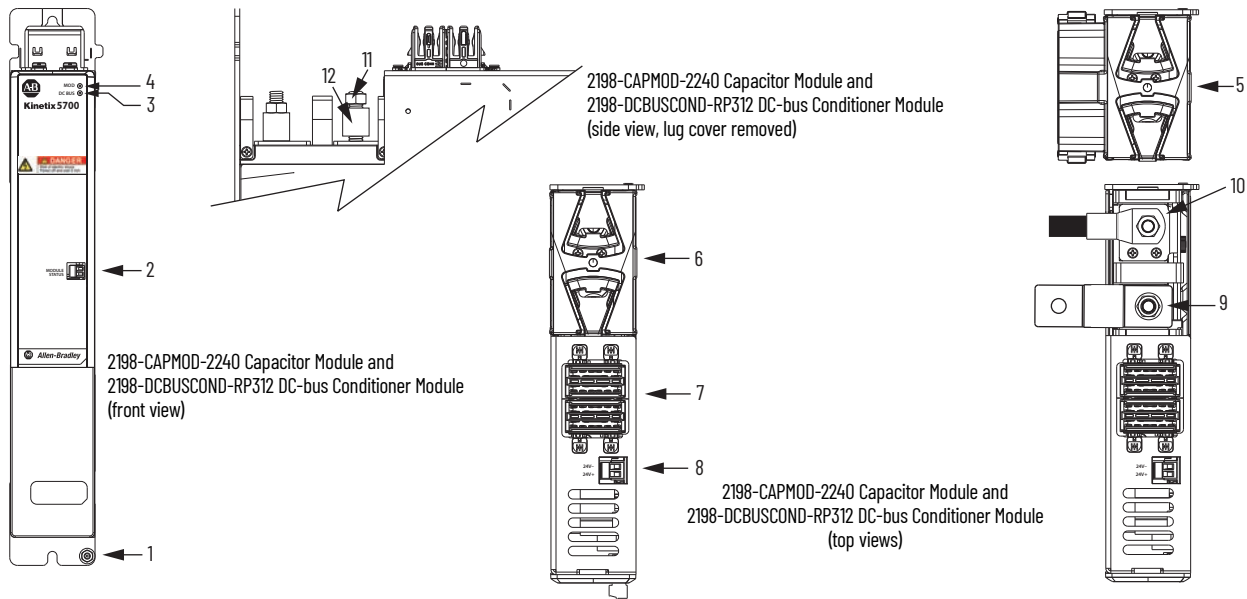

Item	Description
1	Ground stud
2	Module status (MS) connector
3	DC-bus status indicator
4	Module status indicator

Item	Description
5	Stud/lug cover with wires <sup>(1)</sup>
6	Stud cover without wires
7	DC-bus (DC) connector
8	24V control input power (CP) connector

Item	Description
9	DC- M8 stud (external DC-bus), shown with flexible bus-bar <sup>(2)</sup>
10	DC+ M8 stud (external DC-bus), shown with wire lug
11	M8 hex nut
12	Lug spacer

(1) This example shows the lug cover oriented for wires exiting to the left (capacitor module is on the far left of the drive configuration). Rotate lug cover 180° when wires exit to the right (capacitor module is on the far right of the drive configuration).

(2) Flexible bus-bars are included with only the 2198-CAPMOD-DCBUS-IO extension module. So, if you have two capacitor modules, two DC-bus conditioner modules, or a capacitor module and DC-bus conditioner module mounted side by side, you must order the 2198-KITCON-CAPMOD2240 or 2198-KITCON-DCBUSCOND connector set separately.



Extension Module Features and Indicators

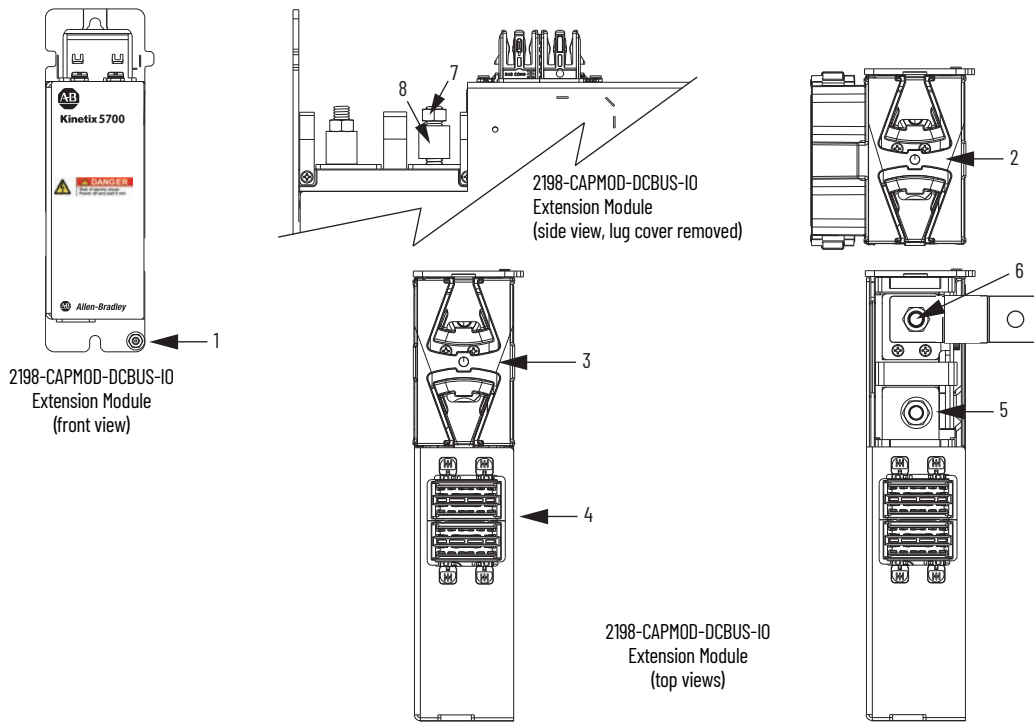

Item	Description
1	Ground lug
2	Stud/lug cover with wires <sup>(1)</sup>
3	Stud cover without wires
4	DC-bus (DC) connector

Item	Description
5	DC- M8 stud (external DC-bus)
6	DC+ M8 stud (external DC-bus), shown with flexible bus-bar <sup>(2)</sup>
7	M8 hex nut
8	Lug spacer

- (1) This example shows the lug cover oriented for wires exiting to the left (extension module is on the far left of drive configuration). Rotate lug cover 180° when wires exit to the right (extension module is on the far right of drive configuration).
- (2) Flexible bus-bars are included with only the 2198-CAPMOD-DCBUS-IO extension module.

Module Specifications

Module Cat. No.	Voltage Range V DC	Capacitance µF	Energy Storage J	Continuous Current A, avg	Weight, approx kg (lb)
2198-CAPMOD-2240	276...747	2240	734	104	3.3 (7.2)
2198-CAPMOD-DCBUS-IO		-	-	104	1.2 (2.7)
2198-DCBUSCOND-RP312		-	-	104	2.0 (4.4)

Capacitor Module, Extension Module, and DC-bus Conditioner Module Dimensions

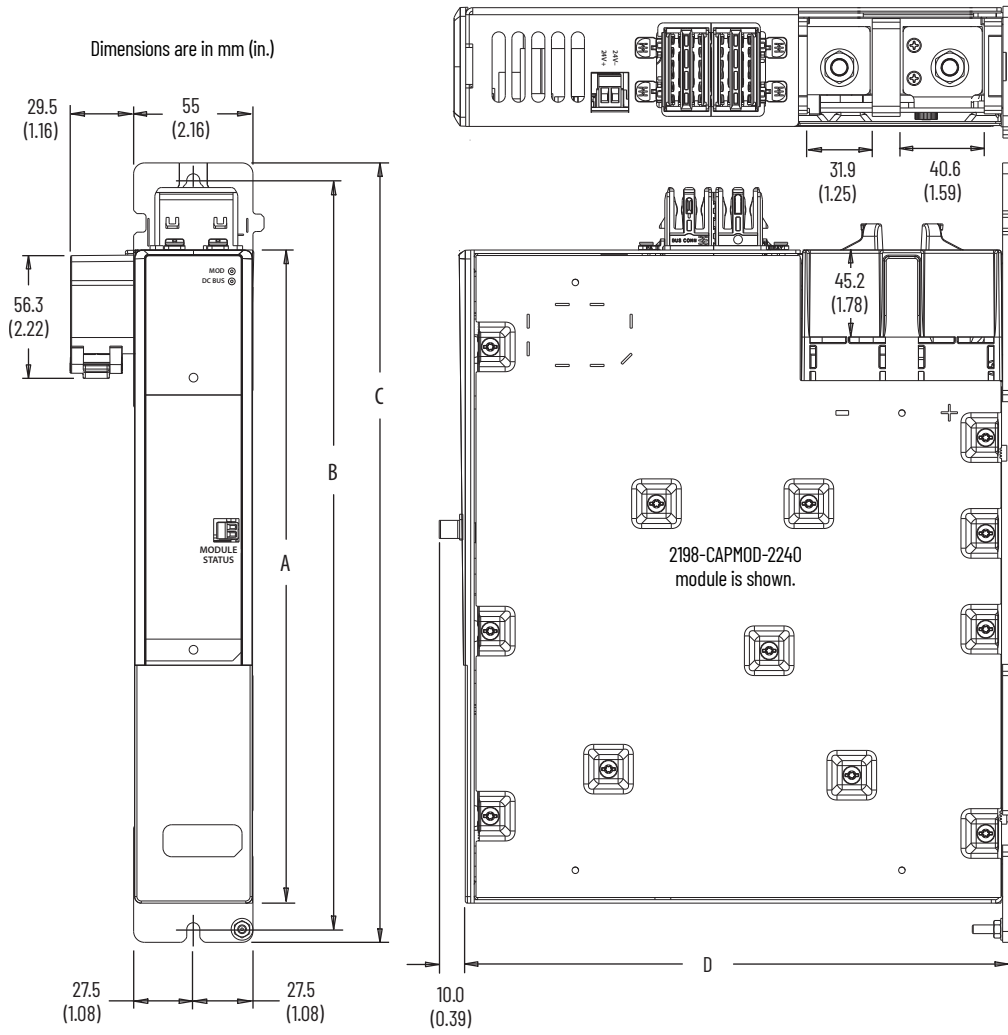

Module Cat. No.	A	B <sup>(1)</sup>	C	D
2198-CAPMOD-2240	300 (11.81)	345 (13.58)	358 (14.09)	253 (10.0)
2198-DCBUSCOND-RP312				
2198-CAPMOD-DCBUS-IO	131 (5.16)	176 (6.93)	189 (7.44)	248 (9.76)

(1) The recommended mounting hardware is M5 (#10-32) steel bolts. Apply 4.0 N•m (35.4 lb•in) maximum torque to each fastener.

## Passive Shunt Modules and Resistors

The Kinetix 5700 passive shunts are external modules that provide additional shunt capacity for applications where the DC-bus power supply's internal shunt capacity is exceeded. Catalog numbers 2198-R014, 2198-R031, and 2198-R127 are composed of resistor coils that are housed inside an enclosure. Catalog number 2198-R004 is a shunt resistor without an enclosure.

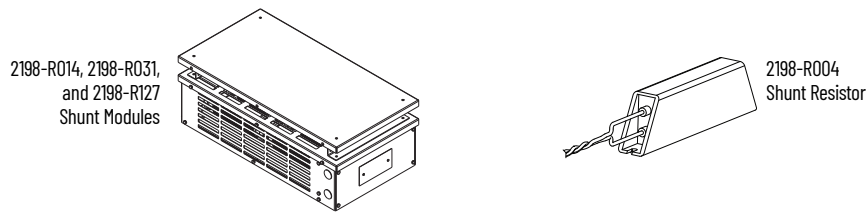

### Shunt Module Specifications

Shunt Module Cat. No.	Resistance Ohms	Continuous Power W	Weight, approx kg (lb)
2198-R004	33	400	1.8 (4.0)
2198-R014	9.4	1400	9.1 (20)
2198-R031	33	3100	16.8 (37)
2198-R127 <sup>(1)</sup>	13	12,700	22.2 (49)

(1) This product presents a lift hazard. To avoid personal injury, use care when lifting the product.

Refer to [Passive Shunt Modules and Resistors Dimensions on page 135](#) for product dimensions and additional specifications.

## Encoder Output Module

The Allen-Bradley encoder output module (catalog number 2198-ABQE) is a DIN-rail mounted EtherNet/IP network-based standalone module capable of outputting encoder pulses to a customer-supplied peripheral device (cameras, for example, used in line-scan vision systems). The encoder output module supports real and virtual axes for systems using the integrated motion on EtherNet/IP network.

These items are required for installation and are ordered separately:

- 2198-K57CK-D15M connector kit, for terminating output cable conductors (1 for each output connector)
- 2198-KITCON-ABQE spare connector and end-anchor set that includes the following:
  - 24V wiring plug for control power input (replacement)
  - Label for recording the IP address and attaching to the encoder output module (replacement)
  - DIN-rail end-anchors for holding the module in position (2 per module)

See [Encoder Output Module on page 137](#) for product dimensions and additional specifications.

## Bulletin 1321 Line Reactors

Bulletin 1321 line reactors help keep equipment running longer by absorbing many of the power line disturbances that can shut down your power supply. For 2198-RPxxx regenerative bus supplies, line reactors can significantly reduce the amount of circulating currents between the integrated LC filter and other devices on the common AC input-power source. For multiple 2198-P208 DC-bus power supplies with common input power, each supply must have its own line reactor.

### Bulletin 1321 Line Reactors

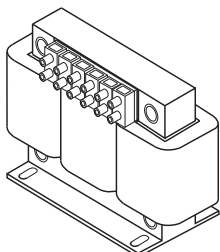

Catalog Numbers  
1321-3R12-B and 1321-3R35-B

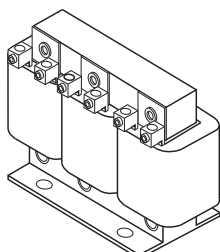

Catalog Numbers  
1321-3R55-B and 1321-3R80-B

For line reactor use-cases with Kinetix 5700 power supplies, see the Kinetix 5700 Servo Drives User Manual, publication [2198-UM002](#).

### Bulletin 1321 Line Reactor Selection

Kinetix 5700 Power Supply	Power Supply Cat. No.	Number of Power Supplies in a Bus Group	Bulletin 1321 Line Reactor Cat. No.	Status
DC-bus Power Supply	2198-P031	1	1321-3R12-B	Recommended
	2198-P070	1	1321-3R35-B	Recommended
	2198-P141	1	1321-3R55-B	Recommended
	2198-P208	1	1321-3R80-B	Recommended
		2		Required
3	Required			
Regenerative Bus Supply	2198-RP088	1	1321-3R35-A	Recommended
	2198-RP200	1	1321-3R100-A	Recommended
	2198-RP263	1	1321-3R160-B	Recommended
	2198-RP312	1	1321-3R200-A	Recommended

For line reactor specifications, terminations, and dimensions, see the 1321 Power Conditioning Products Technical Data, publication [1321-TD001](#).

## AC Line Filters

An AC line filter is required to meet CE requirements. Install the AC line filter as close to the 2198-Pxxx DC-bus power supply or 2198-RPxxx regenerative bus supply as possible.

See [AC Line Filter Dimensions and Specifications on page 138](#) for product dimensions and additional specifications.

## DC-bus Link Connector Kits

DC-bus link connector kits are used to extend DC-bus power from module-to-module.

**IMPORTANT** Use of the DC-bus link connector kits is required and the zero-stack tab and cutout must be engaged between adjacent drives.

The DC-bus link connector kits are required and comprised of these two components:

- DC-bus links that are inserted between drive modules to extend the DC-bus from module-to-module. DC-bus links are included with inverter modules and the iTRAK power supply as indicated in the table below.
- DC-bus end-caps are inserted into the first and last drive modules to cover the exposed DC-bus connector on both ends of the bus and are included with the DC-bus power supplies and regenerative bus supplies.

### DC-bus Link Connector Example

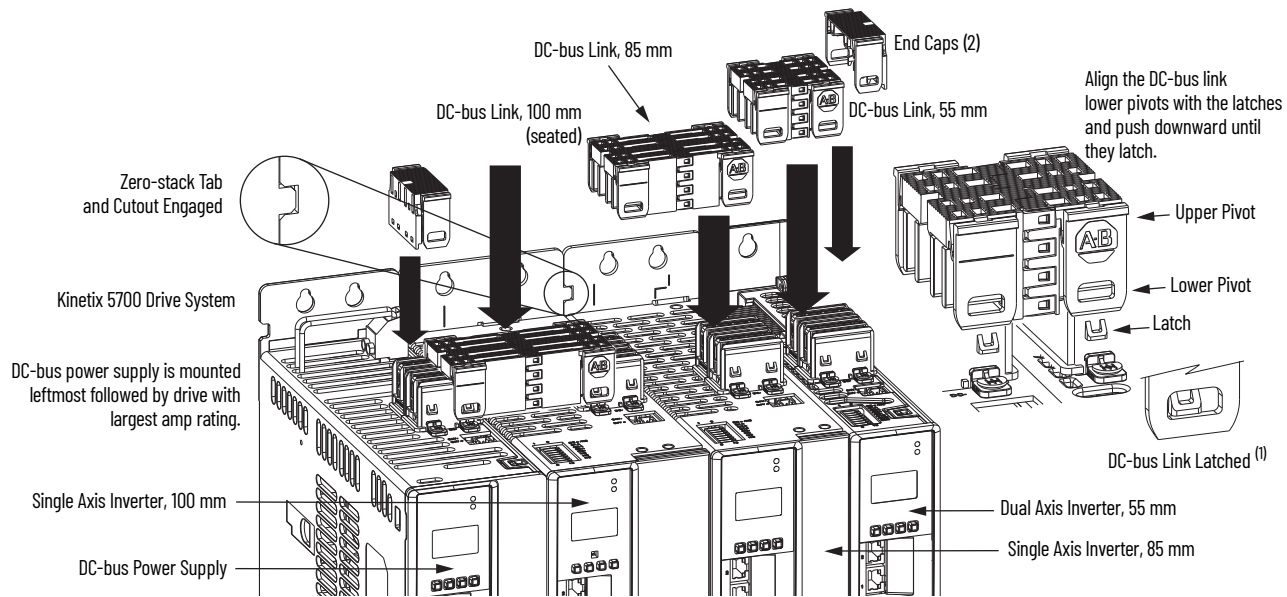





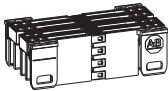

(1) DC-bus links latch on both sides when inserted into the DC-bus connectors. To remove the DC-bus link, depress both sets of upper pivots to unlatch the lower pivots, hold the DC-bus link firmly, and pull upward.

### DC-bus Link Connector Kit Catalog Numbers

Replacement Kit Cat. No.	Description	Module Type	Module Cat. No.	Illustration
2198-BARCON-55DC200	DC-bus link, 55 mm, 208 A	Dual axis inverter	2198-D006-ERSx, 2198-D012-ERSx 2198-D020-ERSx, 2198-D032-ERSx 2198-CAPMOD-2240 2198-CAPMOD-DCBUS-10 2198-DCBUSCOND-RP312	
2198-BARCON-85DC200	DC-bus link, 85 mm, 208 A	Dual axis inverter Single axis inverter	2198-D057-ERSx 2198-S086-ERSx 2198-S130-ERSx	

DC-bus Link Connector Kit Catalog Numbers (Continued)

Replacement Kit Cat. No.	Description	Module Type	Module Cat. No.	Illustration
2198-BARCON-100DC200	DC-bus link, 100 mm, 208 A	Single axis inverter	2198-S160-ERSx	
		iTRAK power supply	2198T-W25K-ER	
2198-BARCON-220DC200	DC-bus link, 220 mm, 208 A	Single-axis inverter	2198-S263-ERSx 2198-S312-ERSx	
2198-BARCON-165DC200	DC-bus link, 165 mm, 208 A	Regenerative Bus Supply	2198-RP088	
2198-BARCON-275DC200	DC-bus link, 275 mm, 208 A	Regenerative Bus Supply	2198-RP200	
2198-BARCON-440DC200	DC-bus link, 440 mm, 208 A	Regenerative Bus Supply	2198-RP263 2198-RP312	
2198-KITCON-ENDCAP200	DC-bus end caps, 208 A	DC-bus power supply	2198-P031, 2198-P070 2198-P141, 2198-P208	
		Regenerative Bus Supply	2198-RP088, 2198-RP200 2198-RP263, 2198-RP312	

## System Mounting Toolkit

The 2198-K5700-MOUNTKIT system mounting toolkit is used to locate the drill-holes for your Kinetix 5700 drive system. Properly spaced drill-holes are essential for engaging the zero-stack tab and cutout from module-to-module so that the DC-bus connectors are spaced properly and accept the DC-bus links. The Kinetix 5700 system mounting toolkit includes the drill-hole guide and mounting bar. Two M4 thread-forming fasteners are also included.

The mounting bar is mounted horizontally on the system panel. The drill-hole guide inserts behind the mounting bar and slides left and right. Holes and slots in the drill-hole guide let you establish the location of each Kinetix 5700 drive module.

### Kinetix 5700 System Mounting Toolkit

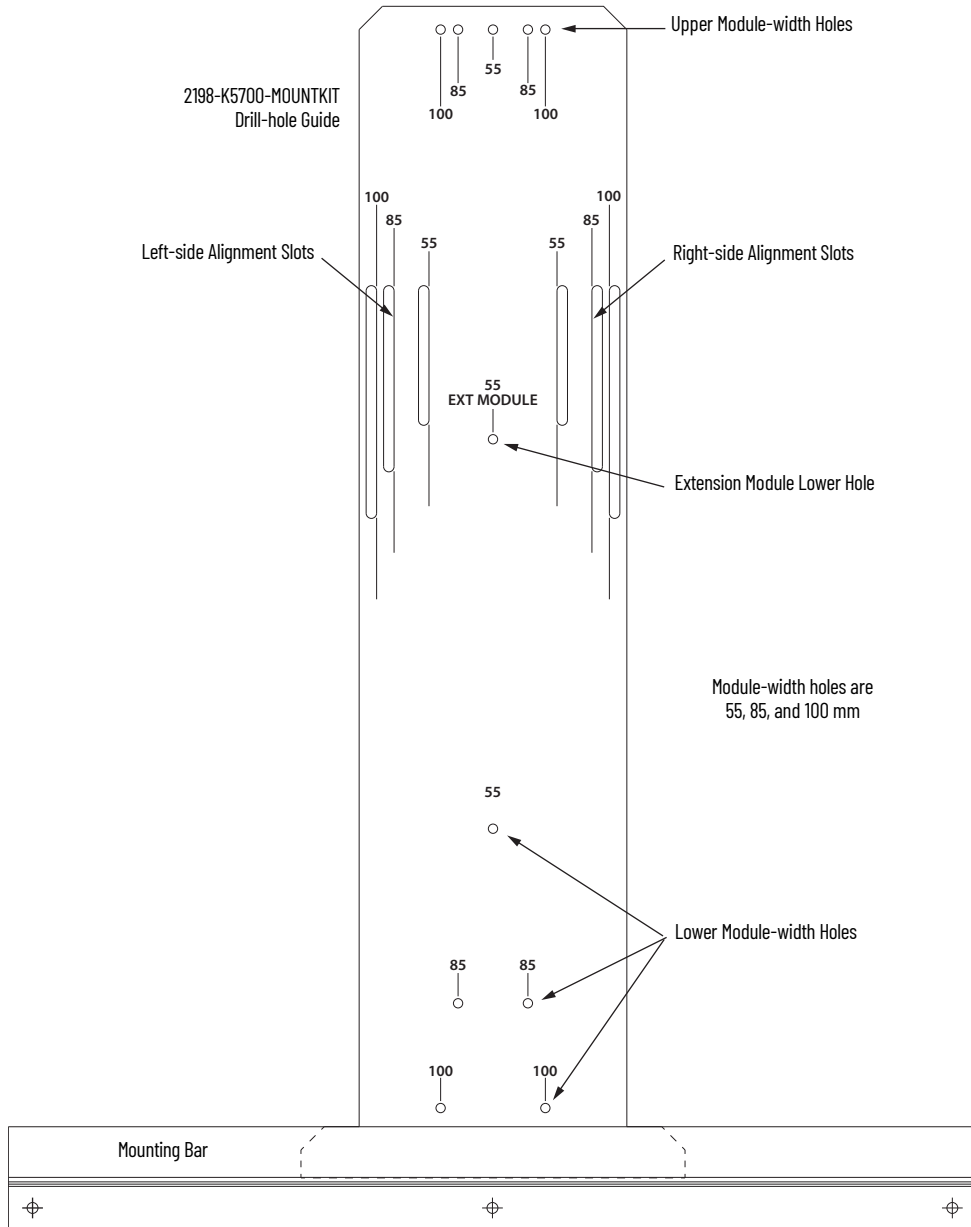

## Universal Feedback Connector Kit

The 2198-K57CK-D15M universal feedback kit passes feedback signals straight through from the encoder to the universal feedback (UFB) connector on the drive. The following encoder feedback types are accepted:

- Hiperface high-resolution absolute (multi-turn and single-turn)
- Heidenhain EnDat high-resolution absolute (digital)
  - EnDat sine/cosine encoders support only Kinetix RDB motors
  - EnDat digital encoders support only third-party motors
- Digital AqB (TTL) and Digital AqB (TTL) with UVW (incremental)
- Sine/Cosine and Sine/Cosine with UVW (incremental)
- Feedback-only, master feedback, or load feedback (absolute single-turn/multi-turn Hiperface)
- Feedback-only, master feedback, or load feedback (incremental)
- Feedback-only, master feedback, or load feedback (generic sine/cosine)

Use the universal feedback connector kit in the following types of installations:

- New installations with Kinetix 5700 servo drives and the compatible motors and actuators
- Existing motor/actuator installations when upgrading with Kinetix 5700 servo drives

### Compatible Allen-Bradley Motors and Actuators

Rotary Motors	Linear Actuators	Kinetix 2090 Feedback Cables <sup>(1)</sup>
Kinetix VPC continuous-duty motors (VPC-Bxxxxx-S, VPC-Bxxxxx-M, and VPC-Bxxxxx-Y)	Kinetix LDAT integrated linear thrusters <sup>(2)</sup>	2090-CFBM7DF-CEAAxx (standard, non-flex) 2090-CFBM7DF-CEAFxx (continuous-flex) 2090-XXNFMF-Sxx (standard, non-flex) 2090-CFBM7DF-CDAFxx (continuous-flex)
Kinetix MPL low-inertia motors		
Kinetix MPM medium-inertia motors	Kinetix MPAS integrated linear stages <sup>(3)</sup>	
Kinetix MPF food-grade motors	Kinetix MPMA multi-axis linear stages <sup>(3)</sup>	
Kinetix MPS stainless-steel motors	Kinetix MPAR electric cylinders	
Kinetix HPK asynchronous servo motors	Kinetix MPAI heavy-duty electric cylinders	
Kinetix RDB motors		
Kinetix MMA asynchronous main motors	Kinetix LDC iron-core linear motors	

(1) These are typical feedback cables. Refer to the Kinetix 5700 Servo Drives Design Guide, publication [KNX-RM010](#), for the cables required for specific drive and motor/actuator combinations.

(2) Kinetix LDAT linear thrusters with absolute high-resolution encoders and incremental encoders are compatible.

(3) Kinetix MPAS and MPMA (ballscrew) linear stages are compatible.

### Universal Feedback Connector Kit Dimensions

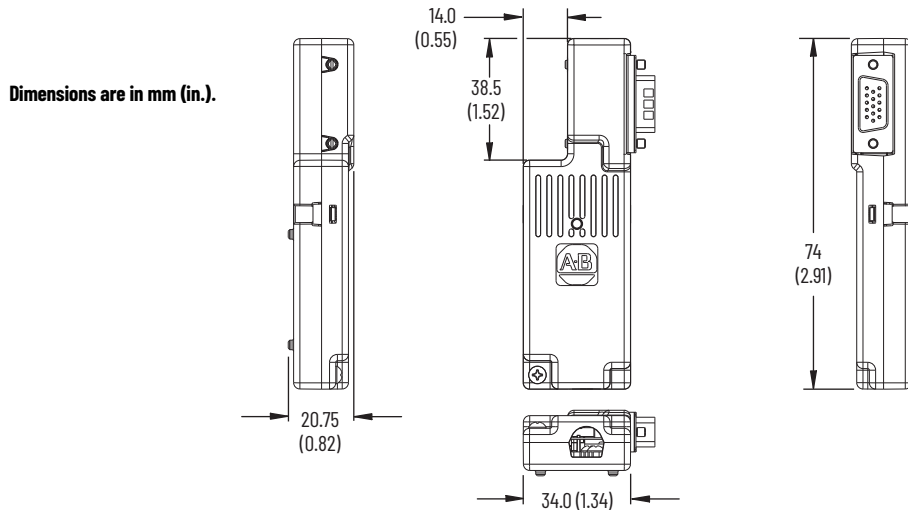



## Hiperface-to-DSL Feedback Converter Kit

The 2198-H2DCK Hiperface-to-DSL feedback kit (series B or later) converts 15-pin Hiperface encoder feedback signals to 2-pin DSL feedback signals on the motor feedback (MF) connector. The following feedback types are accepted:

- Hiperface high-resolution absolute multi-turn and single-turn encoders
- Feedback-only, master feedback, or load feedback (absolute single-turn/multi-turn Hiperface)

Use the converter kit for Hiperface auxiliary-encoder feedback in applications that require dual-loop or load feedback when the 15-pin universal feedback (UFB) connector is already in use for a different compatible feedback type.

### Compatible Allen-Bradley Motors and Actuators

Rotary Motors	Linear Actuators	Kinetix 2090 Feedback Cables <sup>(1)</sup>
Kinetix VPC continuous-duty motors (VPC-Bxxxx-S, VPC-Bxxxx-M, and VPC-Bxxxx-Y)	Kinetix LDAT integrated linear thrusters <sup>(2)</sup>	2090-CFBM7DF-CEAxx (standard, non-flex) 2090-CFBM7DF-CEAFxx (continuous-flex) 2090-XXNFMF-Sxx (standard, non-flex) 2090-CFBM7DF-CDAFxx (continuous-flex)
Kinetix MPL low-inertia motors		
Kinetix MPM medium-inertia motors	Kinetix MPAS integrated linear stages (ballscrew) <sup>(3)</sup>	
Kinetix MPF food-grade motors	Kinetix MPMA multi-axis linear stages (ballscrew) <sup>(3)</sup>	
Kinetix MPS stainless-steel motors	Kinetix MPAR electric cylinders	
Kinetix HPK asynchronous servo motors	Kinetix MPAI heavy-duty electric cylinders	
Kinetix MMA asynchronous servo motors		

(1) These are typical feedback cables. Refer to the Kinetix 5700 Servo Drives Design Guide, publication [KNX-RM010](#), for the cables required for specific drive and motor/actuator combination.

(2) Kinetix LDAT linear thrusters with absolute high-resolution encoders are compatible. Linear stages with incremental encoders are not compatible.

(3) Kinetix MPAS and MPMA (ballscrew) linear stages are compatible. Direct-drive linear stages are not compatible.

The 2198-H2DCK feedback converter kit can be used to convert Hiperface feedback signals from the motor encoder to DSL feedback signals that are accepted by the motor feedback (MF) connector. Compatible Allen-Bradley rotary motors and linear actuators must have high-resolution absolute encoders. Cable length restrictions also exist, refer to [Maximum Cable Lengths](#) on [page 19](#) for more information.

For product dimensions, refer to [Hiperface-to-DSL Feedback Converter Kit on page 143](#).

## External Auxiliary Encoders

These Allen-Bradley external encoders are suitable for use with your Kinetix 5700 servo drive application.

## Integrated Motion on EtherNet/IP Encoders

Bulletin 842E-CM Integrated Motion on EtherNet/IP absolute encoders are designed for motion control applications that require feedback-only axes. These encoders support the standard motion instruction set in the Studio 5000 Logix Designer<sup>®</sup> application. By providing auxiliary feedback directly through an EtherNet/IP network, these encoders eliminate the need for point-to-point wiring.

### Bulletin 842E-CM Integrated Motion on EtherNet/IP Absolute Encoders

Cat. No.	Description	Features
842E-CM-Sxxxx	18-bit single-turn resolution	<ul style="list-style-type: none"> <li>• Support for the standard motion instruction set in the Studio 5000 Logix Designer application</li> <li>• EtherNet/IP interface compliant with IEEE 1588</li> <li>• Support for linear, ring, and star Ethernet topologies</li> <li>• IP67 environmental rating</li> <li>• Available with solid and hollow shaft</li> </ul>
842E-CM-Mxxxx	30-bit multi-turn resolution	

The Bulletin 843ES CIP Safety™ absolute network encoder is designed for safety applications that require speed, direction, or position monitoring safety functions.

### Bulletin 843ES Absolute Network Encoders

Cat. No.	Description	Description
843ES-SIPxBAX	<ul style="list-style-type: none"> <li>• 18-bit (standard) single-turn resolution</li> <li>• 15-bit (safety) single-turn resolution</li> </ul>	<ul style="list-style-type: none"> <li>• Rated up to and including SIL 3 according to IEC 61800-5-2, IEC 620261, and IEC 61508-1</li> <li>• Rated up to and including PLe, Cat. 3, according to ISO 13849-1</li> <li>• Clamping, synchro, and square flange options for solid shaft</li> <li>• Blind-hollow shaft available with stator coupling</li> <li>• Feather-key solid shaft to prevent relative rotation</li> <li>• Dual Ethernet ports with embedded EtherNet/IP switch for linear networks and Device Level Ring topologies</li> <li>• IP67 washdown rating</li> </ul>
843ES-MIPxBAX	12-bit multi-turn resolution	

Refer to <http://ab.rockwellautomation.com/motion-control/absolute-encoder> for more information.

### Bulletin 842HR Sine/Cosine Encoders

Bulletin 842HR sine/cosine encoders combine the advantages of incremental and absolute encoder technologies in a single, standalone unit targeted for high-performance digital servo drive systems. The Bulletin 842HR is a 15-bit encoder featuring a hybrid digital/analog interface, transmitting sine/cosine signals via analog channels for incremental feedback and delivering absolute position information through the digital RS-485 channel.

#### Bulletin 842HR, Size 25, Sine/Cosine Encoders

Cat. No.	Description	Features
842HR-MJDZ115FWYD	<ul style="list-style-type: none"> <li>• Square flange</li> <li>• 3/8 in. solid-shaft</li> </ul>	<ul style="list-style-type: none"> <li>• Absolute feedback for position control</li> <li>• RS-485 interface</li> <li>• Hiperface interface compatible</li> <li>• IP66 (IEC 529)</li> </ul>
842HR-SJDZ115FWYD	<ul style="list-style-type: none"> <li>• 17-pin connector</li> <li>• 5...12V operating voltage</li> </ul>	

Refer to <http://ab.rockwellautomation.com/motion-control/absolute-encoder> for more information.

### Bulletin 844D Incremental Encoders

Bulletin 844D through-shaft incremental encoders are used to electronically monitor the position or speed of a rotating shaft. Shaft position is converted to digital pulses in an A quad B format. A Zero Index Channel is also included with all models.

#### Bulletin 844D Hollow-shaft (HS35 Style) Encoders

Cat. No.	Resolution	Description
844D-B5CC1FW	1024 PPR	<ul style="list-style-type: none"> <li>• 5/8 in. through-shaft</li> <li>• 3/8 in. bolt on 2.5...4.0 in. diameter radius</li> <li>• MS connector, 10-pin</li> <li>• 5V DC input /5V DC DLD output (3487)</li> </ul>
844D-B5CC1CS	2048 PPR	
844D-B5CC1DR	5000 PPR	

## Bulletin 847H Incremental Encoders

The Bulletin 847H optical incremental encoders electronically digitize shaft motion of a rotating element by converting mechanical motion to an electronic digital format. Incremental square waves are accumulated in a counter as position feedback. The encoder provides code disk resolutions up to 5000 pulses per revolution at a signal frequency response of 210 kHz. The Bulletin 847H encoder is housed in a size 25, NEMA Type 4 and 13, IP66 (IEC 529), enclosure making it suitable for many of today's industrial environments.

### Bulletin 847H, Size 25, High Performance, Encoders

Cat. No.	Resolution	Description
847H-SJDN14FWY2	1024 PPR	<ul style="list-style-type: none"> <li>• Square flange</li> <li>• 3/8 in. with flat shaft</li> <li>• 5V DC input /5V DC DLD RS-422 output</li> <li>• Radial connector (side)</li> </ul>
847H-SJDN14CSY2	2048 PPR	
847H-SJDN14DRY2	5000 PPR	

## Bulletin 847T Incremental Encoders

Bulletin 847T optical incremental encoders are used to electronically monitor the position of a rotating shaft. Shaft motion is converted to digital pulses that are accumulated and evaluated by various electronic controllers. The Bulletin 847T encoder provides code disk resolutions of up to 3000 pulses per revolution, and a frequency response of up to 100 kHz. The Bulletin 847T encoder is a heavy duty, NEMA Type 4, and IP66 (IEC 529) rated optical incremental shaft encoder that is housed in a 2-in. diameter enclosure.

### Bulletin 847T, Size 20, Heavy Duty Encoders

Cat. No.	Resolution	Description
847T-DN13EFW	1024 PPR	<ul style="list-style-type: none"> <li>• Square flange</li> <li>• 3/8 in. with flat shaft</li> <li>• 5V DC input /5V DC DLD output</li> <li>• Channel A, B, and Z signals</li> <li>• 10-pin connector</li> </ul>
847T-DN13ECS	2048 PPR	

Refer to <http://ab.rockwellautomation.com/motion-control/incremental-optical-encoder> for more information on Bulletin 844 and 847 incremental external encoders.

## Replacement Parts and Connector Kits - Kinetix 5700 Servo Drives

Replacement parts and kits available for Kinetix 5700 servo drives include the DSL feedback connector kit, power-sharing bus-bars, power connector sets, and fan kits.

### DSL Feedback Connector Kit

The 2198-KITCON-DSL feedback connector kit is required for making feedback connections from Kinetix VP motors and actuators, and is included with each 2090-CSxM1DE cable. Motor power, brake, and the 2-wire feedback connections are made by using a single 2090-CSxM1DE cable. Refer to the Kinetix Rotary and Linear Motion Cable Specifications Technical Data, publication [KNX-TD004](#), for cable specifications.

#### 2090-CSxM1DE Single Motor Cables

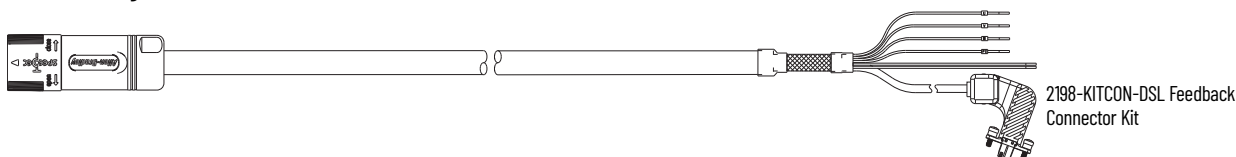

Motor power, brake, and the 2-wire feedback connections can also be made by using a single 2090-CSxM1DG cable, however, the 2198-KITCON-DSL feedback connector kit is not included and must be ordered separately. Refer to the Kinetix Rotary and Linear Motion Cable Specifications, publication [KNX-TD004](#), for cable specifications.

#### 2090-CSxM1DG Single Motor Cables

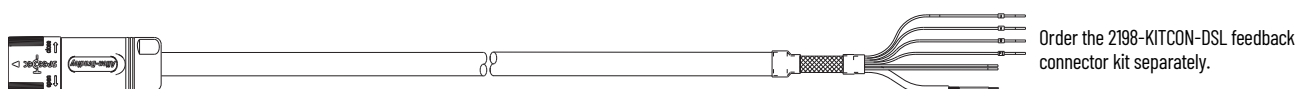

## Power Sharing Bus-bars and Connector Sets



### Replacement Power Sharing Bus-bars

Replacement Kit Cat. No.	Description	Module Type	Module Cat. No.	Illustration
2198-BARCON-55DCAC100	Bus-bar connectors, 55 mm, quantity 8	DC-bus power supplies	2198-P031, 2198-P070	
		Dual-axis inverters	2198-D006-ERSx 2198-D012-ERSx 2198-D020-ERSx 2198-D032-ERSx	
		Capacitor module	2198-CAPMOD-2240	
		DC-bus conditioner module	2198-DCBUSCOND-RP312	
2198-BARCON-85DCAC100	Bus-bar connectors, 85 mm, quantity 8	DC-bus power supplies	2198-P141, 2198-P208	
		Dual-axis inverters	2198-D057-ERSx	
		Single-axis inverters	2198-S086-ERSx, 2198-S130-ERSx	
2198-BARCON-100DC100	Bus-bar connectors, 100 mm, quantity 8	Single-axis inverters	2198-S160-ERSx	
		iTRAK power supply	2198T-W25K-ER	

### Replacement Connector Sets

Replacement Kit Cat. No.	Description	Module Type	Module Cat. No.	Illustration
2198-KITCON-P070	<ul style="list-style-type: none"> <li>One AC input power (IPD) connector</li> <li>One 24V input power (CP) connector</li> <li>One contactor enable (CED) connector</li> <li>One passive shunt (RC) connector</li> <li>One I/O (IOD) connector</li> </ul>	DC-bus power supplies	2198-P031 2198-P070	
2198-KITCON-P208			2198-P141 2198-P208	

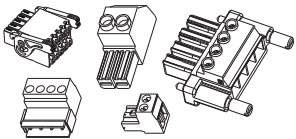
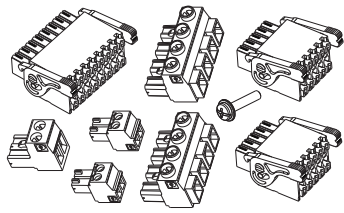
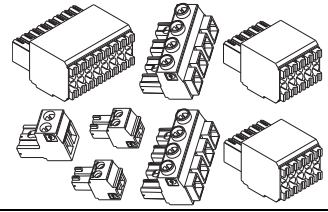
Replacement Connector Sets (Continued)

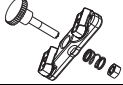
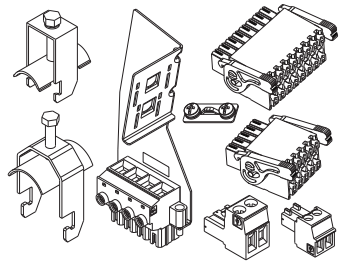
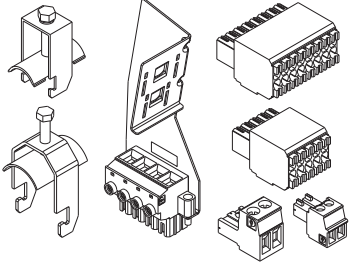
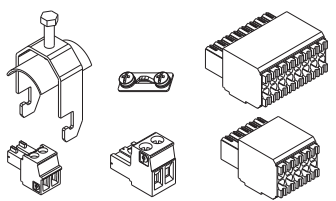
Replacement Kit Cat. No.	Description	Module Type	Module Cat. No.	Illustration
2198-KITCON-RP088	<ul style="list-style-type: none"> <li>• One AC input power (IPD) connector</li> <li>• One 24V input power (CP) connector</li> <li>• One contactor enable (CED) connector</li> <li>• One active shunt (RC) connector</li> <li>• One I/O (IOD) connector</li> </ul>	Regenerative bus supplies	2198-RP088	
2198-KITCON-RP200			2198-RP200	
2198-KITCON-RP312			2198-RP263 2198-RP312	
2198-KITCON-D032-L	<ul style="list-style-type: none"> <li>• One 24V input power (CP) connector</li> <li>• Two motor power (MP) connectors</li> <li>• Two motor brake (BC) connectors</li> <li>• Two I/O (IOD) connectors</li> <li>• One Safe Torque Off (STO) connector</li> <li>• One ground screw</li> </ul> IOD and STO connector plugs are compatible with 2198-Dxxx-ERS4 drives and 2198-Dxxx-ERS3 (series B or later) drives.	Dual-axis inverters	2198-D006-ERSx 2198-D012-ERSx 2198-D020-ERSx 2198-D032-ERSx	
2198-KITCON-D057-L			2198-D057-ERSx	
2198-KITCON-D032	<ul style="list-style-type: none"> <li>• One 24V input power (CP) connector</li> <li>• Two motor power (MP) connectors</li> <li>• Two motor brake (BC) connectors</li> <li>• Two I/O (IOD) connectors</li> <li>• One Safe Torque Off (STO) connector</li> </ul> IOD and STO connector plugs are compatible with 2198-Dxxx-ERS3 (series A) drives.	Dual-axis inverters	2198-D006-ERS3 2198-D012-ERS3 2198-D020-ERS3 2198-D032-ERS3 (series A drives)	
2198-KITCON-D057			2198-D057-ERS3 (series A drives)	
2198-5700-CLAMPSPACER	Two clamp spacers	Dual-axis inverters	2198-Dxxx-ERSx	
2198-K5700-DACLAMPKIT	One cable clamp	Dual-axis inverters	2198-Dxxx-ERSx	
2198-KITCON-S160-L	<ul style="list-style-type: none"> <li>• One 24V input power (CP) connector</li> <li>• One motor power (MP) connector and clamp bracket</li> <li>• Two motor cable clamps</li> <li>• One motor brake (BC) connector</li> <li>• One I/O (IOD) connector</li> <li>• One Safe Torque Off (STO) connector</li> <li>• One ground jumper</li> </ul> IOD and STO connector plugs are compatible with 2198-Sxxx-ERS4 drives and 2198-Sxxx-ERS3 (series B or later) drives.	Single-axis inverters	2198-S086-ERSx 2198-S130-ERSx 2198-S160-ERSx	
2198-KITCON-S160	<ul style="list-style-type: none"> <li>• One 24V input power (CP) connector</li> <li>• One motor power (MP) connector and clamp bracket</li> <li>• Two motor cable clamps</li> <li>• One motor brake (BC) connector</li> <li>• One I/O (IOD) connector</li> <li>• One Safe Torque Off (STO) connector</li> </ul> IOD and STO connector plugs are compatible with 2198-Sxxx-ERS3 (series A) drives.	Single-axis inverters	2198-S086-ERS3 2198-S130-ERS3 2198-S160-ERS3 (series A drives)	
2198-KITCON-S312-L	<ul style="list-style-type: none"> <li>• One 24V input power (CP) connector</li> <li>• One motor cable clamp</li> <li>• One motor brake (BC) connector</li> <li>• One I/O (IOD) connector</li> <li>• One Safe Torque Off (STO) connector</li> <li>• One ground jumper</li> </ul> IOD and STO connector plugs are compatible with 2198-Sxxx-ERS4 drives and 2198-Sxxx-ERS3 (series B or later) drives.	Single-axis inverters	2198-S263-ERSx 2198-S312-ERSx	

**Replacement Connector Sets (Continued)**

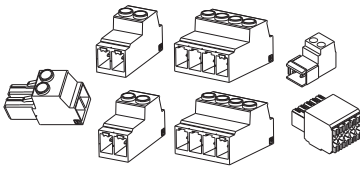
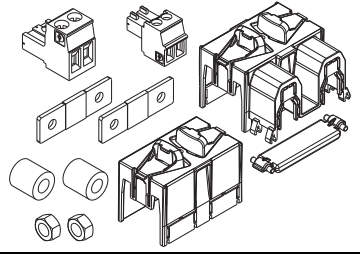
Replacement Kit Cat. No.	Description	Module Type	Module Cat. No.	Illustration
2198T-W25K-KITCON	<ul style="list-style-type: none"> <li>• One 24V input power (CP) connector</li> <li>• Two DC-bus output (IDC) connectors</li> <li>• Two control output (ICP) connectors</li> <li>• One I/O (IOD) connector</li> <li>• One iTRAK PS ready (IR) connector</li> </ul>	iTRAK power supply	2198T-W25K-ER	
2198-KITCON-CAPMOD2240	<ul style="list-style-type: none"> <li>• One stud/lug cover with wires</li> <li>• One stud cover without wires</li> <li>• One bottom plate</li> <li>• One 24V input power (CP) connector</li> <li>• One module status (MS) connector</li> <li>• Two flexible bus-bars</li> <li>• Two lug spacers</li> <li>• Two M8 hex nuts</li> </ul>	Capacitor module	2198-CAPMOD-2240	
2198-KITCON-DCBUSCOND		Extension module	2198-CAPMOD-DCBUS-IO	
		DC-bus conditioner module	2198-DCBUSCOND-RP312	

**Fan Kits**

**Replacement Fan Kits**

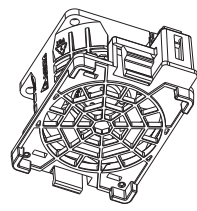
Replacement Kit Cat. No.	Description	Module Type	Module Cat. No.	Illustration
2198-SK1-FAN060	Replacement fan and carrier assembly	Regenerative bus supply	2198-RP088	
2198-SK1-FAN092	Replacement fan and carrier assembly	Regenerative bus supplies	2198-RP200 2198-RP263 2198-RP312	
		Single-axis inverters	2198-S263-ERSx 2198-S312-ERSx	

# ArmorKinetix System



On-machine drives include Distributed Servo Motor (DSM) and Distributed Servo Drive (DSD). Both are single axis inverters and can be powered by a Diode Front End (DFE) module. The connection between the in-cabinet system and the on-machine inverters is established by using the Power Interface Module (PIM) that distributes DC power and communication signals by using a single cable (hybrid cable). Each PIM module can support up to 24 axes. If more than 24 axes are needed, you can use multiple PIM modules.

## ArmorKinetix System Modules Features and Indicators

Use these illustrations to identify the connectors and indicators for the ArmorKinetix® modules.

Figure 1 - ArmorKinetix Power Interface Module (PIM) Features and Indicators

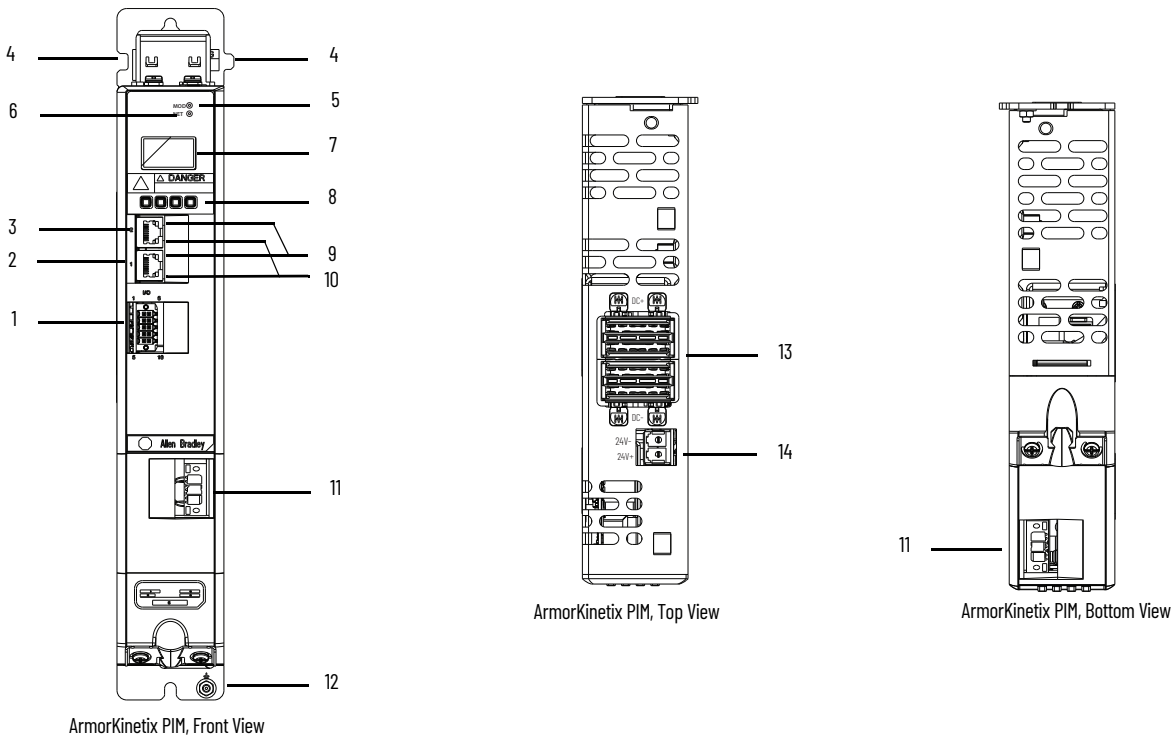

Item	Description
1	Digital inputs connector
2	Ethernet (PORT1) RJ45 connector
3	Ethernet (PORT2) RJ45 connector
4	Zero-stack mounting tab/cutout
5	Module status indicator
6	Network status indicator
7	LCD display

Item	Description
8	Navigation pushbuttons
9	Link speed status indicators
10	Link/Activity status indicators
11	Hybrid cable power connector
12	Ground terminal
13	DC bus (DC) connector
14	24V control input power (CP) connector

Figure 2 - ArmorKinetix Distributed Servo Drive Module (DSD) Features and Indicators

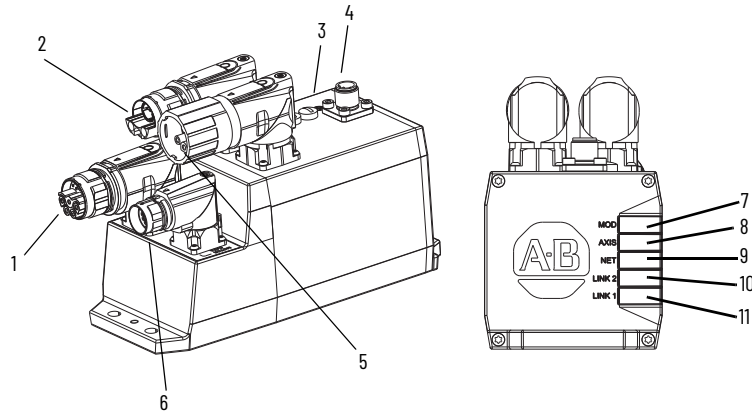

Item	Description
1	Motor power and feedback connector
2	Hybrid cable input
3	IP address rotary switches
4	Digital inputs (IOD) connector
5	Hybrid cable output
6	Motor feedback connector

Item	Description
7	MOD - module status indicator
8	Axis status indicator
9	Network status indicator
10	Link 2 status indicator
11	Link 1 status indicator

Figure 3 - ArmorKinetix Distributed Servo Motor Module (DSM) Features and Indicators

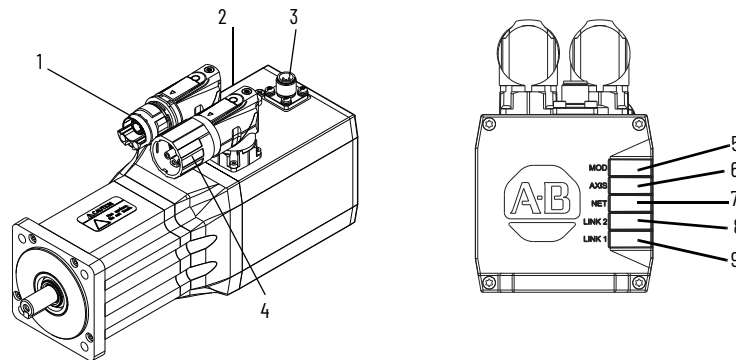

Item	Description
1	Hybrid cable input
2	IP address rotary switches
3	Digital inputs (IOD) connector
4	Hybrid cable output
5	MOD - module status indicator

Item	Description
6	Axis status indicator
7	Network status indicator
8	Link 2 status indicator
9	Link 1 status indicator



## Catalog Numbers - ArmorKinetix DSM Modules

2198 - DSMxxx - ERSx - B 075 1A- C J 11 A A

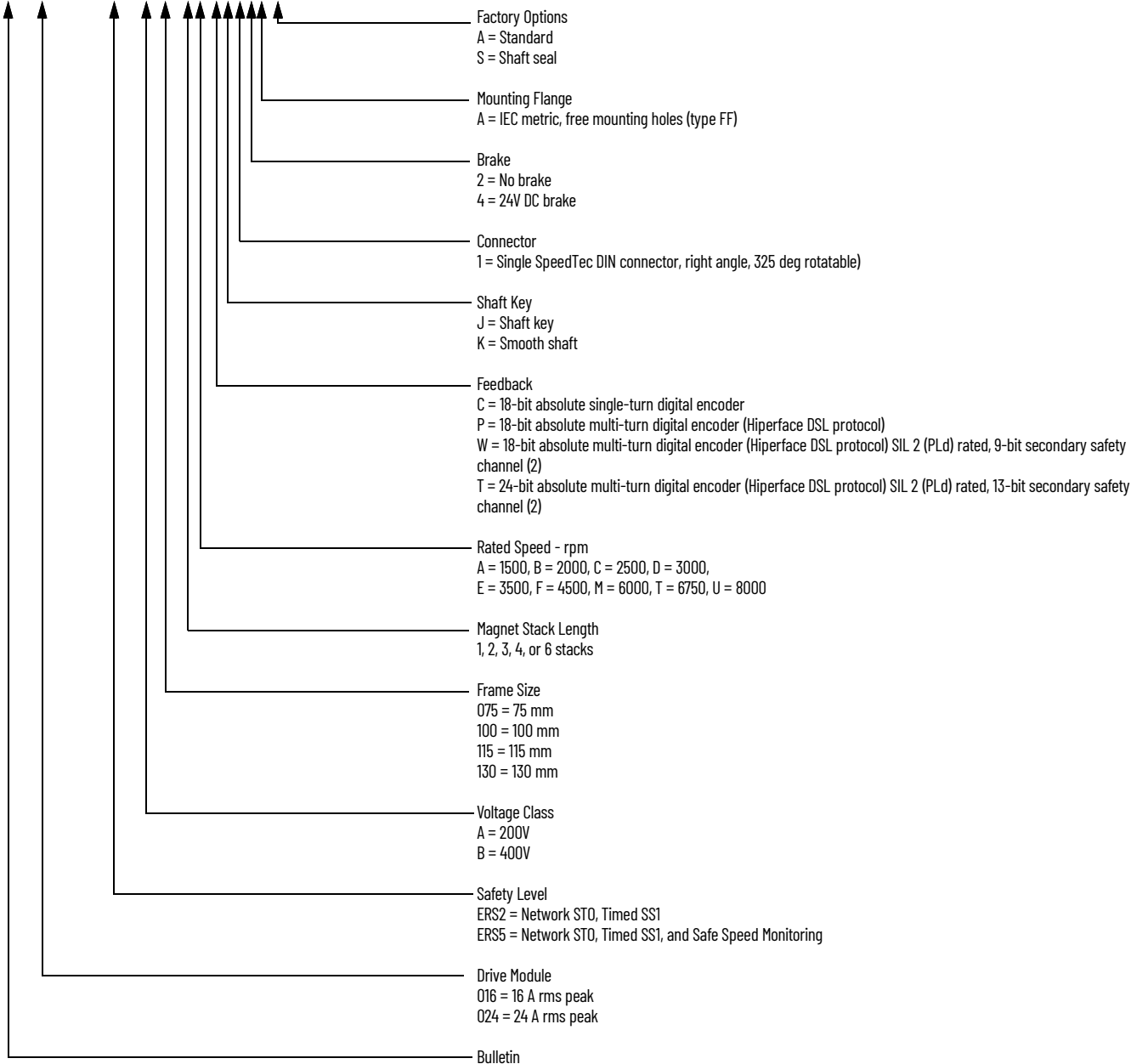

## Catalog Numbers - ArmorKinetix DSD Modules

2198 - DSDxxx - ERSx

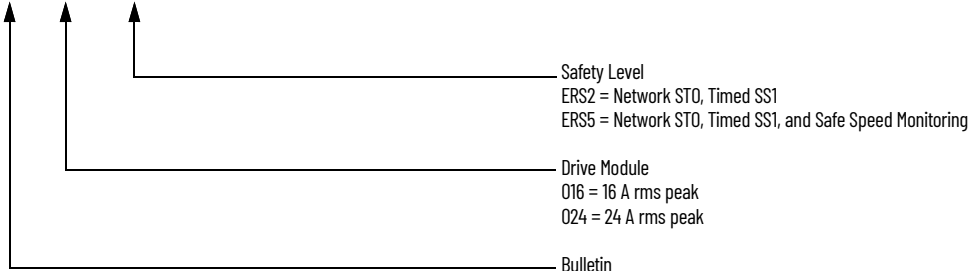

## ArmorKinetix 2090 Cable System

### Hybrid Cable:

- Daisy chain cable connection between DSx modules simplifies the system connection.
- TPE cable material for continuous-flex cable
- UL PVVA recognized
- 2090-CDHIFS-12AFxxxx are available in 0.1 m (0.3 ft) increments between 3...5 m (9.8...16.4 ft) and 0.5 m (1.6 ft) increments between 5...50 m (16.4...164.0 ft)
- 2090-CDHP1S-12AFxxxx are available in 0.1 m (0.3 ft) increments between 0.1...5 m (0.3...16.4 ft) and 0.5 m (1.6 ft) increments between 5...30 m (16.4...164.0 ft)
- 2090-CDHP1S-12AFJ is 0.3 m (0.98 ft) in length

### Motor Power/Feedback Cable:

- Single cable motor power/feedback connection between DSD modules and Kinetix VPL motors or motor power connection between DSD modules and Kinetix MPL, Kinetix linear, and induction motors
- Polyurethane PUR cable material for Halogen-free continuous-flex cable
- UL PVVA recognized
- 2090-CSBM1P7-14AFxx and 2090-CPWFLP7-14AFxx are available in 1 m (3.2 ft) increments up to 4 m (13.1 ft)

### Feedback Cable:

- Feedback cable between DSD modules and Kinetix MPL motors, Kinetix linear motors, induction motors, and auxiliary feedback device
- PUR cable material for Halogen-Free continuous-flex cable
- UL CYJV recognized
- 2090-CFBFLS7-CDAFxx and 2090-CFBM7S7-CDAFxx are available in 1 m (3.2 ft) increments up to 4 m (13.1 ft)

### Hybrid Ethernet Extension Cable:

- Connecting between DSx modules and Kinetix 5700 in-cabinet drives or Ethernet switch devices.
- TPE cable material for continuous-flex cable
- UL CYJV recognized
- 2090-CDET is 0.5 m (1.6 ft) in length

**IMPORTANT** Due to the unique characteristics of Kinetix 2090 single cable technology, designed for and tested with ArmorKinetix DSx modules, building your own cables or using third-party cable is not an option.

## Motor Connector/Cable Compatibility

ArmorKinetix DSD and DSM modules are equipped with SpeedTec DIN connectors.

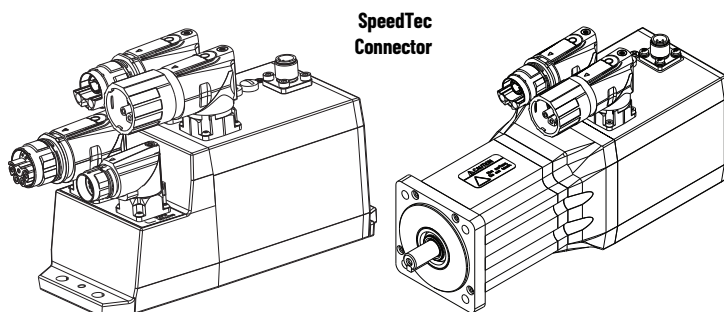

- DSD and DSM modules
- Receives only single cable plugs
- Attach cable plug with one-quarter turn

### SpeedTec DIN Single Cable Plug



- 2090-CDHIFS-12AFxxxx (DSD and DSM)
- 2090-CDHP1S-12AFxxxx (DSD and DSM)
- 2090-CSBM1P7-14AFxx (DSD)
- 2090-CPWFLP7-14AFxx (DSD)
- 2090-CFBFLS7-CDAFxx (DSD)
- 2090-CFBM7S7-CDAFxx (DSD)
- 2190-CDHP1S-12AFJ
- 2090-CDET

For ArmorKinetix 2090 motor cables specifications, refer to Kinetix Motion Accessories Specifications Technical Data, publication [KNX-TD004](#).

**Connector Terminator Dimensions - 2090-CDHT, 2090-CDFT, 2090-CDPT**

Dimensions in millimeters (inches). Dimensions are not intended to be used for manufacturing purposes.

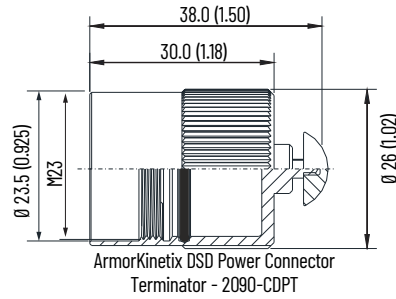
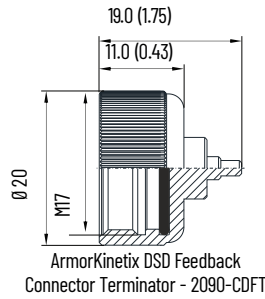
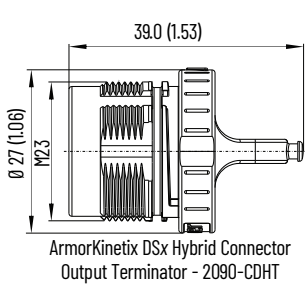

- The terminator kits are designed for IP protection on DSx modules when a connector is not used
- 2090-CDHT and 2090-CDPT are UL PVVA recognized
- 2090-CDFT is UL CYJV recognized

**ArmorKinetix DSM Options**

ArmorKinetix DSM modules are available with these configurable options:

- Single-turn, multi-turn, non-safety, and safety encoder.
- 24V DC holding brake.
- Choice of keyed or keyless shaft.
- Shaft seal kits are available, as are replacement kits for field installation. Shaft seals are made of nitrile and kits include a lubricant to reduce wear.

---

**IMPORTANT** Shaft seals are subject to wear and require periodic inspection and replacement. Replacement is recommended every 3 months, not to exceed 12 months, depending on use.

---

**Shaft Seal Kit Catalog Numbers**

Motor Cat. No.	Shaft Seal Kit Cat. No.
2198-DSMxxx-A075xx and 2198-DSMxxx-B075xx	VPL-SSN-F063075
2198-DSMxxx-A100xx and 2198-DSMxxx-B100xx	MPL-SSN-A3B3
2198-DSMxxx-A115xx and 2198-DSMxxx-B115xx	MPL-SSN-A4B4
2198-DSMxxx-A130xx and 2198-DSMxxx-B130xx	MPL-SSN-A5B5

Refer to the Kinetix VPL Low-inertia Servo Motors Installation Instructions, publication [VPL-IN001](#), for more information on motor accessories.

# Technical Specifications - ArmorKinetix System Modules

## DC-bus Power Supply Specifications

Attribute	2198-P031	2198-P070	2198-P141	2198-P208
AC input voltage	195...528V rms, three-phase (240/480V nom)			
AC input frequency	47...63 Hz			
Main AC input current <sup>(1)</sup> 195...528V (rms) three-phase	11.2 A	27.0 A	49.6 A	73.1 A
Max inrush (0...pk)	33.0 A	33.0 A	33.0 A	33.0 A
Peak AC input current 195...528V (rms) three-phase	33.4 A	74.3 A	148.7 A	219.2 A
Line loss ride through	20 ms			
Control power DC input voltage	24V DC ±10%			
Control power DC input current <sup>(1) (2)</sup>	0.8 A <sub>DC</sub>		1.9 A <sub>DC</sub>	
Nominal bus output voltage	276...747V DC			
Continuous output current to bus Three-phase	10.5 A <sub>DC</sub>	25.5 A <sub>DC</sub>	46.9 A <sub>DC</sub>	69.2 A <sub>DC</sub>
Peak output current to bus Three-phase	31.6 A <sub>DC</sub>	70.3 A <sub>DC</sub>	140.8 A <sub>DC</sub>	207.6 A <sub>DC</sub>
Peak output current duration <sup>(3)</sup>	1.0 s	1.0 s	1.0 s	0.1 s
Continuous output power to bus Nom (240V rms, three-phase at 1/2 power) Nom (480V rms, three-phase)	3.5 kW 7.0 kW	8.5 kW 17.0 kW	15.5 kW 31.0 kW	23.0 kW 46.0 kW
Peak output power to bus Nom (240V rms, three-phase at 1/2 power) Nom (480V rms, three-phase)	10.5 kW 21.0 kW	23.0 kW 46.0 kW	46.5 kW 93.0 kW	69.0 kW 138.0 kW
Bus overvoltage 240V, nom AC input 480V, nom AC input	460V DC 832V DC			
Internal shunt resistance	37.5 Ω		13.5 Ω	
Internal shunt power	75 W		200 W	
Shunt on 240V, nom AC input 480V, nom AC input	400V plus 30V x bus regulator capacity/utilization <sup>(4)</sup> 775V plus 30V x bus regulator capacity/utilization <sup>(4)</sup>			
Shunt off 240V, nom AC input 480V, nom AC input	390V plus 30V x bus regulator capacity/utilization <sup>(4)</sup> 765V plus 30V x bus regulator capacity/utilization <sup>(4)</sup>			
Efficiency	99%			
Internal Capacitance	585 μF	780 μF	1640 μF	2050 μF
Capacitive energy absorption	129 J	172 J	362 J	453 J
Short-circuit current rating	200,000 A (rms) symmetrical			

(1) All modules are limited to 1 power cycle per minute.

(2) For current values when motors include a holding brake and additional information, refer to [Control Power Current Specifications](#) on [page 13](#).

(3) Peak output current duration with 10% duty cycle.

(4) The shunt on and shunt off voltages increase during periods of shunting activity to promote sharing of shunt power in multi-axis configurations. Shunt utilization is equivalent to the BusRegulatorCapacity tag in the Studio 5000 Logix Designer application.

**ArmorKinetix DSD Module Power Specifications**

Attribute	2198-DSD016-ERSx	2198-DSD024-ERSx
Bandwidth <sup>(1)</sup> Velocity loop, max Current loop	400 Hz 1000 Hz	
PWM frequency	4000 Hz	
Continuous output current (rms)	5.3 A at 40 °C (104 °F) 4.8 A at 55 °C (131 °F)	8 A at 40 °C (104 °F) 7 A at 55 °C (131 °F)
Continuous output current (0-pk)	7.5 A at 40 °C (104 °F) 6.8 A at 55 °C (131 °F)	11.3 A at 40 °C (104 °F) 9.9 A at 55 °C (131 °F)
Peak output current (rms)	16 A at 40 °C (104 °F) 14 A at 55 °C (131 °F)	24 A at 40 °C (104 °F) 19 A at 55 °C (131 °F)
Peak output current (0-pk)	22.6 A at 40 °C (104 °F) 19.8 A at 55 °C (131 °F)	34 A at 40 °C (104 °F) 26.9 A at 55 °C (131 °F)
Continuous power out (nom) Nom (240V rms, three-phase at 1/2 power) Nom (480V rms, three-phase)	1.8 kW 3.6 kW	2.25 kW 5.5 kW
DC input current at 276...747V DC	5.6 A	8.5 A
Internal Capacitance	5.2 µF	

(1) Bandwidth values vary based on tuning parameters and mechanical components.

**ArmorKinetix DSM Module (200V-class) Performance Specifications**

Motor Cat. No.	Rated Speed rpm	Maximum Speed rpm	Continuous Stall Torque N·m (lb·in)	Peak Stall Torque N·m (lb·in)	Motor Rated Output kW (Hp)	Rotor Inertia <sup>(1)</sup> kg·m <sup>2</sup> (lb·in·s <sup>2</sup> )	Motor Weight, <sup>(1)</sup> approx kg (lb)
2198-DSM016-ERSx-A0751E	4800	4800	0.95 (8.41)	2.27 (20.00)	0.38 (0.51)	0.0000136 (0.00012)	2.96 (6.52)
2198-DSM016-ERSx-A0752E	4800	4800	1.58 (13.98)	4.09 (36.20)	0.63 (0.85)	0.000025 (0.00022)	3.51 (7.73)
2198-DSM024-ERSx-A0753C	3300	3300	2.12 (18.76)	6.91 (61.15)	0.59 (0.79)	0.0000365 (0.00032)	4.07 (8.97)
2198-DSM024-ERSx-A0753E	4600	4600	2.05 (18.14)	6.23 (55.00)	0.67 (0.90)	0.0000365 (0.00032)	4.07 (8.97)
2198-DSM016-ERSx-A1001C	2800	2800	1.77 (15.66)	3.78 (33.00)	0.51 (0.68)	0.000044 (0.00039)	4.09 (9.01)
2198-DSM016-ERSx-A1002C	3000	3000	3.38 (30.00)	7.82 (69.00)	1.03 (1.38)	0.000078 (0.00069)	5.66 (12.47)
2198-DSM024-ERSx-A1003C	2250	2250	4.05 (35.80)	11.15 (99.00)	0.87 (1.17)	0.00012 (0.0010)	5.91 (13.02)
2198-DSM024-ERSx-A1003E	3750	3750	3.98 (35.00)	10.64 (93.00)	1.31 (1.76)		5.91 (13.02)
2198-DSM016-ERSx-A1152B	2150	2150	4.91 (43.00)	13.12 (116.00)	0.98 (1.31)	0.00026 (0.0023)	5.85 (12.89)
2198-DSM024-ERSx-A1152E	3300	3300	4.82 (43.00)	12.58 (111.00)	1.41 (1.89)		5.85 (12.89)
2198-DSM024-ERSx-A1153A	1600	1600	6.35 (56.00)	20.26 (179.00)	0.93 (1.25)	0.00038 (0.0033)	7.43 (16.38)
2198-DSM024-ERSx-A1153C	2300	2300	5.98 (53.00)	18.09 (160.00)	1.32 (1.77)		7.43 (16.38)
2198-DSM016-ERSx-A1303A	1150	1150	8.10 (72.00)	20.70 (183.00)	0.94 (1.26)	0.00040 (0.0035)	8.94 (19.70)
2198-DSM024-ERSx-A1303B	2000	2000	7.65 (68.00)	19.92 (176.20)	1.37 (1.84)		8.94 (19.70)
2198-DSM024-ERSx-A1304A	1600	1600	9.52 (84.00)	25.17 (223.00)	1.55 (2.08)	0.00052 (0.0046)	10.50 (23.14)
2198-DSM024-ERSx-A1306A	1250	1250	11.90 (105.00)	31.21 (277.0)	1.44 (1.94)	0.00078 (0.0069)	13.61 (30.00)

(1) See the ArmorKinetix DSM Servo Motor Brake Specifications on [page 50](#) for brake rotor inertia and brake motor weight.

### ArmorKinetic DSM Servo Motor (400V-class) Performance Specifications

Motor Cat. No.	Rated Speed rpm	Maximum Speed rpm	Continuous Stall Torque N•m (lb•in)	Peak Stall Torque N•m (lb•in)	Motor Rated Output kW (Hp)	Rotor Inertia <sup>(1)</sup> kg•m <sup>2</sup> (lb•in•s <sup>2</sup> )	Motor Weight, <sup>(1)</sup> approx kg (lb)
2198-DSM016-ERSx-B0751M	8000	8000	0.93 (8.20)	2.27 (20.09)	0.54 (0.72)	0.0000136 (0.00012)	2.96 (6.52)
2198-DSM016-ERSx-B0752M	8000	8000	1.58 (13.98)	4.39 (39.00)	0.81 (1.09)	0.0000250 (0.00022)	3.51 (7.73)
2198-DSM024-ERSx-B0753F	4500	6600	1.96 (17.35)	7.02 (62.00)	0.65 (0.87)	0.0000365 (0.00032)	4.07 (8.97)
2198-DSM024-ERSx-B0753M	6000	8000	2.10 (18.59)	6.12 (54.00)	0.78 (1.05)		4.07 (8.97)
2198-DSM016-ERSx-B1001M	6000	6000	1.79 (16.00)	3.78 (34.00)	1.02 (1.37)	0.000044 (0.00039)	4.09 (9.01)
2198-DSM016-ERSx-B1002M	6000	6000	3.33 (30.00)	7.82 (69.00)	1.86 (2.49)	0.000078 (0.00069)	5.66 (12.47)
2198-DSM024-ERSx-B1003F	4750	4750	3.94 (35.00)	11.15 (99.00)	1.65 (2.21)	0.00012 (0.0010)	5.91 (13.02)
2198-DSM024-ERSx-B1003T	7000	7000	3.67 (33.00)	9.27 (82.00)	1.77 (2.37)		5.91 (13.02)
2198-DSM016-ERSx-B1152F	4000	4500	4.90 (43.00)	13.12 (116.00)	1.40 (1.88)	0.00026 (0.0023)	5.85 (12.89)
2198-DSM024-ERSx-B1152T	6500	6500	4.89 (43.00)	12.14 (107.00)	2.16 (2.89)		5.85 (12.89)
2198-DSM024-ERSx-B1153E	3200	3200	6.23 (55.00)	20.33 (180.00)	1.75 (2.35)	0.00038 (0.0033)	7.43 (16.38)
2198-DSM024-ERSx-B1153F	5000	5000	5.80 (51.00)	18.58 (164.00)	2.20 (2.95)		7.43 (16.38)
2198-DSM016-ERSx-B1303C	2250	2250	8.21 (73.00)	20.24 (179.00)	1.83 (2.45)	0.00040 (0.0035)	8.94 (19.70)
2198-DSM024-ERSx-B1303F	4000	4000	7.65 (68.00)	19.71 (174.00)	2.68 (3.60)		8.94 (19.70)
2198-DSM016-ERSx-B1304C	2150	2150	9.81 (87.00)	25.60 (227.00)	1.75 (2.35)	0.00052 (0.0046)	10.50 (23.14)
2198-DSM024-ERSx-B1304E	3500	3500	9.00 (80.00)	24.14 (214.00)	2.71 (3.63)		10.50 (23.14)
2198-DSM024-ERSx-B1306C	2500	2500	11.90 (105.32)	31.21 (276.00)	2.25 (3.02)	0.00078 (0.0069)	13.61 (30.00)

(1) See the ArmorKinetic DSM Servo Motor Brake Specifications on [page 50](#) for brake rotor inertia and brake motor weight.

### ArmorKinetic DSM Servo Motor Brake Specifications

Motor Cat. No.	Backlash, max (brake engaged) arc minutes	Holding Torque N•m (lb•in)	Coil Current at 24V DC A	Brake Response Time		Brake Rotor Inertia kg•m <sup>2</sup> (lb•in•s <sup>2</sup> )	Brake Motor Weight, approx kg (lb)
				Release ms	Engage ms		
2198-DSMxxx-ERSx-A/B0751	30	3.0 (27)	0.567...0.693	66	42	0.0000136 (0.00012)	3.54 (7.80)
2198-DSMxxx-ERSx-A/B0752						0.0000250 (0.00022)	4.10 (9.03)
2198-DSMxxx-ERSx-A/B0753						0.0000365 (0.00032)	4.66 (10.27)
2198-DSMxxx-ERSx-A/B1001		4.18 (37)	0.45...0.55	90	65	0.000044 (0.00039)	4.72 (10.40)
2198-DSMxxx-ERSx-A/B1002						0.000078 (0.00069)	5.98 (13.18)
2198-DSMxxx-ERSx-A/B1003						0.00012 (0.0010)	6.54 (14.41)
2198-DSMxxx-ERSx-A/B1152		6.55 (58)	0.621...0.759	90	95	0.00026 (0.0023)	6.85 (15.10)
2198-DSMxxx-ERSx-A/B1153						0.00038 (0.0033)	8.30 (18.29)
2198-DSMxxx-ERSx-A/B1303						0.00040 (0.0035)	10.04 (22.13)
2198-DSMxxx-ERSx-A/B1304		14.10 (125)	0.738...0.902	125	120	0.00052 (0.0046)	11.61 (25.59)
2198-DSMxxx-ERSx-A/B1306						0.00078 (0.0069)	14.72 (32.45)

**ArmorKinetix DSM Module Specifications (200V - Class)**

Cat. No.	Continuous Stall Current, (rms) (A)	Continuous Stall Current, (0-pk) (A)	Peak Stall Current (rms)	Peak Stall Current (0-pk)	DC Input Current (A dc) at Rated Speed	Continuous Power out (nom) at Rated Speed kW (Hp)	Max Speed
2198-DSM016-ERSx-A0751E-xx1xAx	2.05	2.90	6.45	9.12	1.2	0.38 (0.51)	4800 RPM
2198-DSM016-ERSx-A0752E-xx1xAx	3.40	4.80	12.45	17.61	2.0	0.63 (0.85)	4800 RPM
2198-DSM024-ERSx-A0753C-xx1xAx	2.84	4.01	13.15	18.6	1.9	0.59 (0.79)	3300 RPM
2198-DSM024-ERSx-A0753E-xx1xAx	3.90	5.50	15.21	21.5	2.1	0.67 (0.90)	4600 RPM
2198-DSM016-ERSx-A1001C-xx1xAx	2.35	3.31	7.34	10.38	1.6	0.51 (0.68)	2800 RPM
2198-DSM016-ERSx-A1002C-xx1xAx	4.42	6.24	14.38	20.33	3.2	1.03 (1.38)	3000 RPM
2198-DSM024-ERSx-A1003C-xx1xAx	4.22	5.95	14.29	20.2	2.7	0.87 (1.17)	2250 RPM
2198-DSM024-ERSx-A1003E-xx1xAx	6.47	9.12	19.38	27.4	4.1	1.31 (1.76)	3750 RPM
2198-DSM016-ERSx-A1152B-xx1xAx	4.21	5.94	14.99	21.19	3.1	0.98 (1.31)	2150 RPM
2198-DSM024-ERSx-A1152E-xx1xAx	7.16	10.10	21.78	30.8	4.4	1.41 (1.89)	3300 RPM
2198-DSM024-ERSx-A1153A-xx1xAx	4.14	5.83	15.08	21.33	2.9	0.93 (1.25)	1600 RPM
2198-DSM024-ERSx-A1153C-xx1xAx	5.75	8.11	20.76	29.36	4.1	1.32 (1.77)	2300 RPM
2198-DSM016-ERSx-A1303A-xx1xAx	4.11	5.81	21.92	31.0	2.9	0.94 (1.26)	1150 RPM
2198-DSM024-ERSx-A1303B-xx1xAx	6.21	8.78	20.86	29.5	4.3	1.37 (1.84)	2000 RPM
2198-DSM024-ERSx-A1304A-xx1xAx	6.18	8.72	21.12	29.87	4.8	1.55 (2.08)	1600 RPM
2198-DSM024-ERSx-A1306A-xx1xAx	6.89	9.72	21.00	29.7	4.5	1.44 (1.94)	1250 RPM

**ArmorKinetix DSM Module Specifications (400V - Class)**

Cat. No.	Continuous Stall Current, (rms) (A)	Continuous Stall Current, (0-pk) (A)	Peak Stall Current (rms)	Peak Stall Current (0-pk)	DC Input Current (A dc) at Rated Speed	Continuous Power out (nom) at Rated Speed kW (Hp)	Max Speed (rpm)
2198-DSM016-ERSx-B0751M-xx1xAx	1.91	2.70	6.47	9.12	0.9	0.54 (0.72)	8000
2198-DSM016-ERSx-B0752M-xx1xAx	3.41	4.81	13.40	18.9	1.3	0.81 (1.09)	8000
2198-DSM024-ERSx-B0753F-xx1xAx	2.66	3.75	13.40	18.9	1.0	0.65 (0.87)	6600
2198-DSM024-ERSx-B0753M-xx1xAx	4.00	5.64	14.96	21.09	1.2	0.78 (1.05)	8000
2198-DSM016-ERSx-B1001M-xx1xAx	2.39	3.37	7.36	10.38	1.6	1.02 (1.37)	6000
2198-DSM016-ERSx-B1002M-xx1xAx	4.34	6.12	14.42	20.33	2.9	1.86 (2.49)	6000
2198-DSM024-ERSx-B1003F-xx1xAx	4.11	5.79	14.33	20.2	2.6	1.65 (2.21)	4750
2198-DSM024-ERSx-B1003T-xx1xAx	6.11	8.62	16.98	23.94	2.8	1.77 (2.37)	7000
2198-DSM016-ERSx-B1152F-xx1xAx	4.21	5.93	15.03	21.19	2.2	1.40 (1.88)	4500
2198-DSM024-ERSx-B1152T-xx1xAx	7.38	10.41	21.06	29.7	3.4	2.16 (2.89)	6500
2198-DSM024-ERSx-B1153E-xx1xAx	4.13	5.83	15.13	21.33	2.7	1.75 (2.35)	3200
2198-DSM024-ERSx-B1153F-xx1xAx	5.57	7.86	21.39	30.16	3.4	2.20 (2.95)	5000
2198-DSM016-ERSx-B1303C-xx1xAx	4.18	5.89	12.79	18.04	2.9	1.83 (2.45)	2250
2198-DSM024-ERSx-B1303F-xx1xAx	6.23	8.78	20.92	29.5	4.2	2.68 (3.60)	4000
2198-DSM016-ERSx-B1304C-xx1xAx	4.73	6.67	15.65	22.07	2.7	1.75 (2.35)	2150
2198-DSM024-ERSx-B1304E-xx1xAx	5.86	8.26	20.32	28.65	4.2	2.71 (3.63)	3500
2198-DSM024-ERSx-B1306C-xx1xAx	6.89	9.72	21.06	29.7	3.5	2.25 (3.02)	2500

## Control Power Current Specifications

ArmorKinetic servo drives, the accessory modules, and iTRAK power supply have different 24V DC power consumption. Factors to consider when calculating the combined current demand from your 24V DC power supply include the following:

- Catalog number for each drive in the system
- Whether servo motors include the holding brake option
- Whether the system includes capacitor modules or DC-bus conditioner modules

If using the 24V DC shared-bus connection system to distribute control input power to a drive cluster, output current from the 24V power supply must not exceed 40 A.

### Control Power Current Specifications

Drive Module	Module Cat. No.	24V Current Per Module (non-brake motor) <sup>(1)</sup> A <sub>DC</sub>	24V Inrush Current <sup>(2)</sup> A
DC-bus Power Supplies	2198-PO31	0.8	4.0
	2198-PO70		
	2198-P141	1.9	
	2198-P208		
Dual-axis Inverters	2198-DO06-ERSx	1.4 <sup>(3)</sup>	4.0
	2198-DO12-ERSx		
	2198-DO20-ERSx	1.7 <sup>(3)</sup>	
	2198-DO32-ERSx		
Single-axis Inverters	2198-DO57-ERSx	2.3 <sup>(3)</sup>	4.0
	2198-S086-ERSx	4.6	
	2198-S130-ERSx		
	2198-S160-ERSx		
	2198-S263-ERSx		
2198-S312-ERSx			
PIM Module	2198-PIM070	12	13.2 <sup>(4)</sup>
iTRAK Power Supply <sup>(5)</sup>	2198T-W25K-ER	1.3	2.2
Capacitor Module	2198-CAPMOD-2240	0.1	7.0
Extension Module	2198-CAPMOD-DCBUS-IO	-	-
DC-bus Conditioner Module	2198-DCBUSCOND-RP312	0.1	7.0

(1) For motor-brake current values, see to the Kinetic Rotary Motion Specifications Technical Data, publication [KNX-TD001](#).

(2) Inrush current duration is less than 30 ms.

(3) Values are base current per module.

(4) Values are with no capacitor modules. For Inrush current with capacitor modules, see [24V DC Power Supply Current Demand \(Inrush\) - 2198-PIM070](#).

(5) These values represent only the iTRAK power supply. They do not include the iTRAK motor modules that are connected to the iTRAK power supply and also draw current from this 24V control power input. For more information regarding 24V control power requirements, see iTRAK System with TriMax Bearings User Manual, publication [2198T-UM002](#), or iTRAK 5730 System User Manual, publication [2198T-UM003](#).

**IMPORTANT** If the 24V control-power output current (based on your system calculation) exceeds 40 A, you can insert another control-power input wiring connector at any point in your drive cluster. However, the input connector must always extend the 24V DC-bus from left to right.

### 24V DC Power Supply Current Demand (Inrush) - 2198-PIM070

	4 Axes <sup>(1)</sup>	8 Axes <sup>(1)</sup>	12 Axes <sup>(1)</sup>	16 Axes <sup>(1)</sup>	20 Axes <sup>(1)</sup>	24 Axes <sup>(1)</sup>
1 Capacitor Module <sup>(2)</sup>	7.0 A	8.5 A	10.0 A	11.3 A	13.0 A	14.3 A
6 Capacitor Modules	30.3 A	31.6 A	32.5 A	33.4 A	32.2 A	32.0 A
11 Capacitor Modules	32.8 A	33.2 A	33.5 A	34.0 A	34.4 A	35.0 A

(1) Including two brake motors out of the total number.

(2) One capacitor module is 2.24 mF



**24V DC Power Supply Current Demand (Continuous) - 2198-PIM070**

	4 Axes <sup>(1)</sup>	8 Axes <sup>(1)</sup>	12 Axes <sup>(1)</sup>	16 Axes <sup>(1)</sup>	20 Axes <sup>(1)</sup>	24 Axes <sup>(1)</sup>
58V Continuous Output Current	0.5 A	1.3 A	1.9 A	2.6 A	3.3 A	4.0 A
24V Continuous Input Current	2.5 A	4.5 A	6.0 A	8.0 A	9.8 A	12.0 A

(1) Including two brake motors out of the total number.

**PIM Module Power Output Specification**

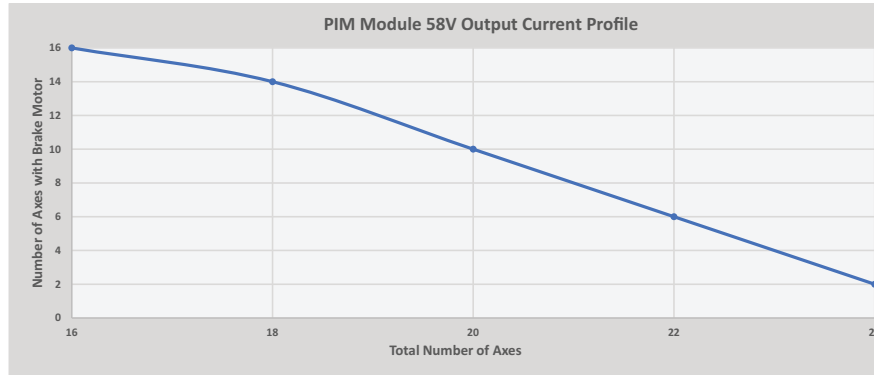

**Peak Current Specifications**

**Load Duty-cycle Profile Example**

$$D = \frac{T_{PK}}{T} \times 100\%$$

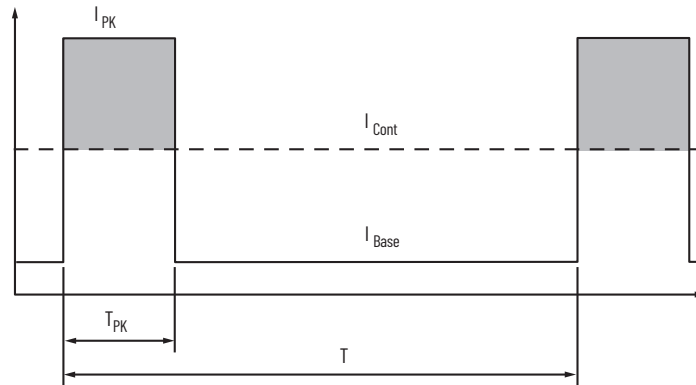

**Overload Ratings for 2198-DSD016-ERSx-B and 2198-DSD024-ERSx-B DSD Modules**

DSD Catalog No.:	Cont. (I <sub>Cont</sub> )	Power (kW)	Intermittent (I <sub>Peak</sub> )	Overload	On	Off	I <sub>Base</sub> (20%)
2198-DSD016-ERSx	5.3 A <sub>rms</sub>	3.6	16 A <sub>rms</sub>	300%	100 ms	900 ms	1.1 A <sub>rms</sub>
2198-DSD024-ERSx	8 A <sub>rms</sub>	5.5	24 A <sub>rms</sub>	300%	100 ms	900 ms	1.6 A <sub>rms</sub>

**Peak Duty Cycle Definition of Terms**

Term	Definition (1)
Continuous Current Rating ( $I_{Cont}$ )	The maximum value of current that can be output continuously.
Peak Current Rating ( $I_{PKmax}$ )	The maximum value of peak current that the drive can output. This rating is valid only for overload times less than $T_{PKmax}$ .
Duty Cycle (D)	The ratio of time at peak to the Application Period is defined as: $D = \frac{T_{PK}}{T} \times 100\%$
Time at Peak ( $T_{PK}$ )	The time at peak current ( $I_{PK}$ ) for a given loading profile. Must be less than or equal to $T_{PKmax}$ .
Peak Current ( $I_{PK}$ )	The level of peak current for a given loading profile. $I_{PK}$ must be less than or equal to the Peak Current Rating ( $T_{PKmax}$ ) of the drive.
Base Current ( $I_{Base}$ )	The level of current between the pulses of peak current for a given loading profile. $I_{Base}$ must be less than or equal to the continuous current rating ( $I_{Cont}$ ) of the drive.
Loading Profile	The loading profile is composed of $I_{PK}$ , $I_{Base}$ , $T_{PK}$ , and D (or T) values and completely specify the operation of the drive in an overload situation. These values are collectively defined as the Loading Profile of the drive.
Application Period (T)	The sum of the times at $I_{PK}$ ( $T_{PK}$ ) and $I_{Base}$ .

(1) All current values are specified as  $A_{rms}$ .

**Peak DSD/DSM Module Overload ( $T_{PK} < 100.0$  ms)**

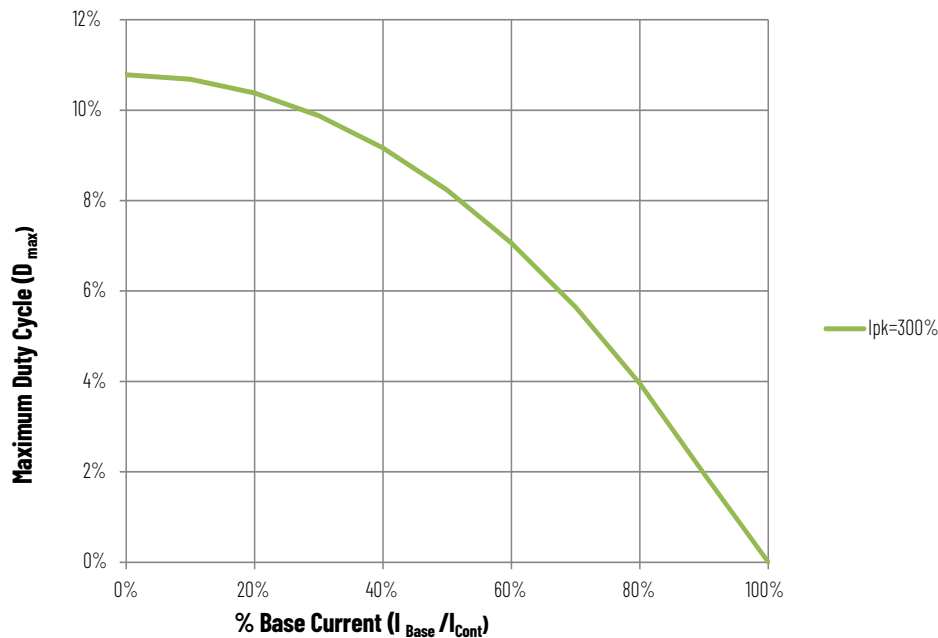

(1) Base current ( $I_{Base}$ ) and peak current ( $I_{PK}$ ) are a percentage of the continuous drive current rating ( $I_{Cont}$ ).

## ArmorKinetix DSM Module Load Force Ratings

ArmorKinetix DSM modules are capable of operating with the maximum radial or maximum axial shaft loads listed in the following tables. Radial loads listed are applied in the middle of the shaft extension. The tables starting below represent an  $L_{10}$  bearing fatigue life of 20,000 hours. This 20,000-hour life does not account for possible application-specific life reduction that can occur due to bearing grease contamination from external sources. Maximum operating speed is limited by motor winding.

### Load Forces on Shaft

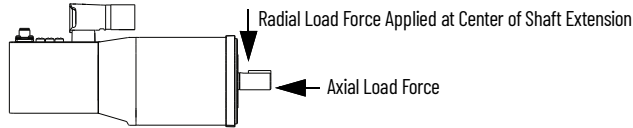

## ArmorKinetix DSM Modules (075 frame size)

### Radial Load Force Ratings (maximum) for Non-brake Motors

Motor Cat. No. (1)	Maximum Speed rpm	Load (kgf) at Speed (rpm)														
		500 kgf	1000 kgf	1500 kgf	2000 kgf	2500 kgf	3000 kgf	3500 kgf	4000 kgf	4500 kgf	5000 kgf	6000 kgf	6500 kgf	7000 kgf	7500 kgf	8000 kgf
2198-DSM016-ERSx-A0751E	4800	33.3	26.4	—	—	20.6 *	—	—	—	—	15.7 *	—	—	—	—	—
2198-DSM016-ERSx-A0752E	4800	36.1	28.6	—	—	21.8 *	—	—	—	—	17.0 *	—	—	—	—	—
2198-DSM024-ERSx-A0753C	3300	37.8	30.0	27.5 *	—	—	—	20.2 *	—	—	—	—	—	—	—	—
2198-DSM024-ERSx-A0753E	4600	37.8	30.0	—	—	23.3 *	—	—	—	—	18.0 *	—	—	—	—	—
2198-DSM016-ERSx-B0751M	8000	—	—	23.1	—	—	18.3	—	—	—	15.7 *	—	—	—	—	13.2
2198-DSM016-ERSx-B0752M	8000	—	—	25.0	—	—	20.8	—	—	—	16.8 *	—	—	—	—	14.3
2198-DSM024-ERSx-B0753F	6600	—	30.0	—	23.8	—	—	20.6 *	—	—	—	—	16.1	16.0*	—	—
2198-DSM024-ERSx-B0753M	8000	—	—	26.2	—	—	19.8	—	—	—	18.0 *	—	—	—	—	15.0

(1) 1.0 kgf = 2.2 lbf or 9.8 N. An asterisk (\*) indicates a load rating measured at an rpm value that is less than the value listed for that column.

### Axial Load Force Ratings (maximum radial load) for Non-brake Motors

Motor Cat. No. (1)	Maximum Speed rpm	Load (kgf) at Speed (rpm)														
		500 kgf	1000 kgf	1500 kgf	2000 kgf	2500 kgf	3000 kgf	3500 kgf	4000 kgf	4500 kgf	5000 kgf	6000 kgf	6500 kgf	7000 kgf	7500 kgf	8000 kgf
2198-DSM016-ERSx-A0751E	4800	30.0	22.2	—	—	16.1 *	—	—	—	—	11.2 *	—	—	—	—	—
2198-DSM016-ERSx-A0752E	4800	31.5	23.3	—	—	16.4 *	—	—	—	—	11.8 *	—	—	—	—	—
2198-DSM024-ERSx-A0753C	3300	32.5	24.1	21.5 *	—	—	—	14.3 *	—	—	—	—	—	—	—	—
2198-DSM024-ERSx-A0753E	4600	32.5	24.1	—	—	17.3 *	—	—	—	—	12.4 *	—	—	—	—	—
2198-DSM016-ERSx-B0751M	8000	—	—	18.6	—	—	13.8	—	—	—	11.2 *	—	—	—	—	9.0
2198-DSM016-ERSx-B0752M	8000	—	—	19.6	—	—	14.5	—	—	—	11.7 *	—	—	—	—	9.5
2198-DSM024-ERSx-B0753F	6600	—	24.1	—	17.8	—	—	14.7 *	—	—	—	—	10.7	10.6*	—	—
2198-DSM024-ERSx-B0753M	8000	—	—	20.2	—	—	14.9	—	—	—	12.4 *	—	—	—	—	9.8

(1) 1.0 kgf = 2.2 lbf or 9.8 N. An asterisk (\*) indicates a load rating measured at an rpm value that is less than the value listed for that column.

**Axial Load Force Ratings (zero radial load) for Non-brake Motors**

Motor Cat. No. (1)	Maximum Speed rpm	Load (kgf) at Speed (rpm)														
		500 kgf	1000 kgf	1500 kgf	2000 kgf	2500 kgf	3000 kgf	3500 kgf	4000 kgf	4500 kgf	5000 kgf	6000 kgf	6500 kgf	7000 kgf	7500 kgf	8000 kgf
2198-DSM016-ERSx-A0751E	4800	37.1	27.5	—	—	19.9 *	—	—	—	—	13.9 *	—	—	—	—	—
2198-DSM016-ERSx-A0752E	4800	37.1	27.5	—	—	19.3 *	—	—	—	—	13.9 *	—	—	—	—	—
2198-DSM024-ERSx-A0753C	3300	37.1	27.5	24.5 *	—	—	—	16.4 *	—	—	—	—	—	—	—	—
2198-DSM024-ERSx-A0753E	4600	37.1	27.5	—	—	19.7 *	—	—	—	—	14.2 *	—	—	—	—	—
2198-DSM016-ERSx-B0751M	8000	—	—	23.0	—	—	17.1	—	—	—	13.9 *	—	—	—	—	11.1
2198-DSM016-ERSx-B0752M	8000	—	—	23.0	—	—	17.1	—	—	—	13.8 *	—	—	—	—	11.1
2198-DSM024-ERSx-B0753F	6600	—	27.5	—	20.3	—	—	16.8 *	—	—	—	—	12.2	12.1*	—	—
2198-DSM024-ERSx-B0753M	8000	—	—	23.0	—	—	17.1	—	—	—	14.2 *	—	—	—	—	11.1

(1) 1.0 kgf = 2.2 lbf or 9.8 N. An asterisk (\*) indicates a load rating measured at an rpm value that is less than the value listed for that column.

**Radial Load Force Ratings (maximum) for Brake Motors**

Motor Cat. No. (1)	Maximum Speed rpm	Load (kgf) at Speed (rpm)														
		500 kgf	1000 kgf	1500 kgf	2000 kgf	2500 kgf	3000 kgf	3500 kgf	4000 kgf	4500 kgf	5000 kgf	6000 kgf	6500 kgf	7000 kgf	7500 kgf	8000 kgf
2198-DSM016-ERSx-A0751E	4800	36.5	29.0	—	—	22.6 *	—	—	—	—	17.2 *	—	—	—	—	—
2198-DSM016-ERSx-A0752E	4800	38.1	30.3	—	—	23.1 *	—	—	—	—	17.9 *	—	—	—	—	—
2198-DSM024-ERSx-A0753C	3300	39.2	31.2	28.5 *	—	—	—	20.9 *	—	—	—	—	—	—	—	—
2198-DSM024-ERSx-A0753E	4600	39.2	31.2	—	—	24.1 *	—	—	—	—	18.7 *	—	—	—	—	—
2198-DSM016-ERSx-B0751M	8000	—	—	25.3	—	—	20.1	—	—	—	17.2 *	—	—	—	—	14.5
2198-DSM016-ERSx-B0752M	8000	—	—	26.4	—	—	21.0	—	—	—	17.8 *	—	—	—	—	15.1
2198-DSM024-ERSx-B0753F	6600	—	31.2	—	24.7	—	—	21.4 *	—	—	—	—	16.7	16.6*	—	—
2198-DSM024-ERSx-B0753M	8000	—	—	27.2	—	—	21.6	—	—	—	18.7 *	—	—	—	—	15.6

(1) 1.0 kgf = 2.2 lbf or 9.8 N. An asterisk (\*) indicates a load rating measured at an rpm value that is less than the value listed for that column.

**Axial Load Force Ratings (maximum radial load) for Brake Motors**

Motor Cat. No. (1)	Maximum Speed rpm	Load (kgf) at Speed (rpm)														
		500 kgf	1000 kgf	1500 kgf	2000 kgf	2500 kgf	3000 kgf	3500 kgf	4000 kgf	4500 kgf	5000 kgf	6000 kgf	6500 kgf	7000 kgf	7500 kgf	8000 kgf
2198-DSM016-ERSx-A0751E	4800	31.8	23.5	—	—	17.1 *	—	—	—	—	11.9 *	—	—	—	—	—
2198-DSM016-ERSx-A0752E	4800	32.7	24.2	—	—	17.0 *	—	—	—	—	12.3 *	—	—	—	—	—
2198-DSM024-ERSx-A0753C	3300	33.4	24.7	22.0 *	—	—	—	14.7 *	—	—	—	—	—	—	—	—
2198-DSM024-ERSx-A0753E	4600	33.4	24.7	—	—	17.7 *	—	—	—	—	12.7 *	—	—	—	—	—
2198-DSM016-ERSx-B0751M	8000	—	—	19.7	—	—	14.6	—	—	—	11.9 *	—	—	—	—	9.5
2198-DSM016-ERSx-B0752M	8000	—	—	20.3	—	—	15.0	—	—	—	12.1 *	—	—	—	—	9.8
2198-DSM024-ERSx-B0753F	6600	—	24.7	—	18.3	—	—	15.1 *	—	—	—	—	11.0	10.9*	—	—
2198-DSM024-ERSx-B0753M	8000	—	—	20.7	—	—	15.3	—	—	—	12.7 *	—	—	—	—	10.0

(1) 1.0 kgf = 2.2 lbf or 9.8 N. An asterisk (\*) indicates a load rating measured at an rpm value that is less than the value listed for that column.

**Axial Load Force Ratings (zero radial load) for Brake Motors**

Motor Cat. No. (1)	Maximum Speed rpm	Load (kgf) at Speed (rpm)														
		500 kgf	1000 kgf	1500 kgf	2000 kgf	2500 kgf	3000 kgf	3500 kgf	4000 kgf	4500 kgf	5000 kgf	6000 kgf	6500 kgf	7000 kgf	7500 kgf	8000 kgf
2198-DSM016-ERSx-A0751E	4800	37.1	27.5	—	—	19.9 *	—	—	—	—	13.9 *	—	—	—	—	—
2198-DSM016-ERSx-A0752E	4800	37.1	27.5	—	—	19.3 *	—	—	—	—	13.9 *	—	—	—	—	—
2198-DSM024-ERSx-A0753C	3300	37.1	27.5	24.5 *	—	—	—	16.4 *	—	—	—	—	—	—	—	—
2198-DSM024-ERSx-A0753E	4600	37.1	27.5	—	—	19.7 *	—	—	—	—	14.2 *	—	—	—	—	—
2198-DSM016-ERSx-B0751M	8000	—	—	23.0	—	—	17.1	—	—	—	13.9 *	—	—	—	—	11.1
2198-DSM016-ERSx-B0752M	8000	—	—	23.0	—	—	17.1	—	—	—	13.8 *	—	—	—	—	11.1
2198-DSM024-ERSx-B0753F	6600	—	27.5	—	20.3	—	—	16.8 *	—	—	—	—	12.2	12.1*	—	—
2198-DSM024-ERSx-B0753M	8000	—	—	23.0	—	—	17.1	—	—	—	14.2 *	—	—	—	—	11.1

(1) 1.0 kgf = 2.2 lbf or 9.8 N. An asterisk (\*) indicates a load rating measured at an rpm value that is less than the value listed for that column.

## ArmorKinetix DSM Modules (100...135 frame size)

### Radial Load Force Ratings (maximum) for Non-brake Motors

Motor Cat. No. (1)	Maximum Speed rpm	Load (kgf) at Speed (rpm)														
		500 kgf	750 kgf	1000 kgf	1500 kgf	2000 kgf	2500 kgf	3000 kgf	3500 kgf	4000 kgf	4500 kgf	5000 kgf	5500 kgf	6000 kgf	6500 kgf	7000 kgf
2198-DSM016-ERSx-A1001C	2800	79.1	—	62.8	—	49.8	—	44.6 *	—	—	—	—	—	—	—	—
2198-DSM016-ERSx-A1002C	3000	87.9	—	69.7	—	55.4	—	48.4	—	—	—	—	—	—	—	—
2198-DSM024-ERSx-A1003C	2250	93.6	—	74.3	64.9	—	56.7 *	—	—	—	—	—	—	—	—	—
2198-DSM024-ERSx-A1003E	3750	93.6	—	74.3	—	59.0	—	—	—	47.8 *	—	—	—	—	—	—
2198-DSM016-ERSx-A1152B	2150	98.8	—	78.4	68.5	—	60.8 *	—	—	—	—	—	—	—	—	—
2198-DSM024-ERSx-A1152E	3300	98.8	—	78.4	—	62.2	—	—	52.7 *	—	—	—	—	—	—	—
2198-DSM024-ERSx-A1153A	1600	106.4	—	84.5	—	67.0	—	—	—	—	—	—	—	—	—	—
2198-DSM024-ERSx-A1153C	2300	106.4	—	84.5	73.8	—	64.0 *	—	—	—	—	—	—	—	—	—
2198-DSM016-ERSx-A1303A	1150	132.9	—	105.5	92.2	—	—	—	—	—	—	—	—	—	—	—
2198-DSM024-ERSx-A1303B	1950	132.9	—	105.5	92.2	84.4 *	—	—	—	—	—	—	—	—	—	—
2198-DSM024-ERSx-A1304A	1600	140.2	122.5	112.2 *	—	95.2 *	—	—	—	—	—	—	—	—	—	—
2198-DSM024-ERSx-A1306A	1250	150.0	—	119.1	104.0	—	—	—	—	—	—	—	—	—	—	—
2198-DSM016-ERSx-B1001M	6000	—	—	—	—	49.8	—	43.5	—	39.6	—	—	—	34.6	—	—
2198-DSM016-ERSx-B1002M	6000	—	—	—	60.9	—	—	48.4	—	—	42.2	—	—	38.4	—	—
2198-DSM024-ERSx-B1003F	4750	—	—	74.3	64.9	—	—	51.5	—	—	—	44.2 *	—	—	—	—
2198-DSM024-ERSx-B1003T	7000	—	—	—	64.9	—	54.8	—	—	—	45.0	—	—	—	—	38.9
2198-DSM016-ERSx-B1152F	4000	—	—	78.4	—	62.2	—	54.4	—	—	47.5	—	—	—	—	—
2198-DSM024-ERSx-B1152T	6500	—	—	—	68.5	—	57.8	—	—	49.4	—	—	—	—	42.0	—
2198-DSM024-ERSx-B1153E	3200	106.4	—	84.5	—	67.0	—	—	57.3 *	—	—	—	—	—	—	—
2198-DSM024-ERSx-B1153F	5000	—	—	84.5	—	67.0	—	58.6	—	—	—	49.4	—	—	—	—
2198-DSM016-ERSx-B1303C	2250	132.9	—	105.5	92.2	—	80.5 *	—	—	—	—	—	—	—	—	—
2198-DSM024-ERSx-B1303F	4000	—	—	105.5	—	83.7	—	74.0 *	—	66.5	—	—	—	—	—	—
2198-DSM016-ERSx-B1304C	2150	140.2	—	111.3	99.5 *	—	86.2 *	—	—	—	—	—	—	—	—	—
2198-DSM024-ERSx-B1304E	3500	—	—	111.3	97.2	—	84.3 *	—	73.3	—	—	—	—	—	—	—
2198-DSM024-ERSx-B1306C	2500	150.0	—	119.1	—	100.8 *	87.7	—	—	—	—	—	—	—	—	—

(1) 1.0 kgf = 2.2 lbf or 9.8 N. An asterisk (\*) indicates a load rating measured at an rpm value that is less than the value listed for that column.

**Axial Load Force Ratings (maximum radial load) for Non-brake Motors**

Motor Cat. No. (1)	Maximum Speed rpm	Load (kgf) at Speed (rpm)														
		500 kgf	750 kgf	1000 kgf	1500 kgf	2000 kgf	2500 kgf	3000 kgf	3500 kgf	4000 kgf	4500 kgf	5000 kgf	5500 kgf	6000 kgf	6500 kgf	7000 kgf
2198-DSM016-ERSx-A1001C	2800	25.0	—	19.0	—	10.0	—	10.0 *	—	—	—	—	—	—	—	—
2198-DSM016-ERSx-A1002C	3000	30.0	—	22.0	—	16.0	—	13.0	—	—	—	—	—	—	—	—
2198-DSM024-ERSx-A1003C	2250	33.0	—	24.0	20.0	—	17.0 *	—	—	—	—	—	—	—	—	—
2198-DSM024-ERSx-A1003E	3750	33.0	—	24.0	—	18.0	—	—	—	13.0 *	—	—	—	—	—	—
2198-DSM016-ERSx-A1152B	2150	44.0	—	32.0	27.0	—	23.0 *	—	—	—	—	—	—	—	—	—
2198-DSM024-ERSx-A1152E	3300	44.0	—	32.0	—	24.0	—	—	15.0 *	—	—	—	—	—	—	—
2198-DSM024-ERSx-A1153A	1600	48.0	—	35.0	—	26.0	—	—	—	—	—	—	—	—	—	—
2198-DSM024-ERSx-A1153C	2300	48.0	—	35.0	29.0	—	24.0 *	—	—	—	—	—	—	—	—	—
2198-DSM016-ERSx-A1303A	1150	39.0	—	29.0	24.0	—	—	—	—	—	—	—	—	—	—	—
2198-DSM024-ERSx-A1303B	1950	39.0	—	29.0	24.0	22.0 *	—	—	—	—	—	—	—	—	—	—
2198-DSM024-ERSx-A1304A	1600	43.0	36.0	32.0 *	—	26.0 *	—	—	—	—	—	—	—	—	—	—
2198-DSM024-ERSx-A1306A	1250	48.0	—	36.0	30.0	—	—	—	—	—	—	—	—	—	—	—
2198-DSM016-ERSx-B1001M	6000	—	—	—	—	14.0	—	11.0	—	10.0	—	—	—	8.0	—	—
2198-DSM016-ERSx-B1002M	6000	—	—	—	18.0	—	—	13.0	—	—	11.0	—	—	10.0	—	—
2198-DSM024-ERSx-B1003F	4750	—	—	24.0	20.0	—	—	15.0	—	—	—	12.0 *	—	—	—	—
2198-DSM024-ERSx-B1003T	7000	—	—	—	20.0	—	16.0	—	—	—	12.0	—	—	—	—	10.0
2198-DSM016-ERSx-B1152F	4000	—	—	32.0	—	24.0	—	20.0	—	—	17.0	—	—	—	—	—
2198-DSM024-ERSx-B1152T	6500	—	—	—	27.0	—	21.0	—	—	17.0	—	—	—	—	14.0	—
2198-DSM024-ERSx-B1153E	3200	48.0	—	35.0	—	26.0	—	—	21.0 *	—	—	—	—	—	—	—
2198-DSM024-ERSx-B1153F	5000	—	—	35.0	—	26.0	—	22.0	—	—	—	17.0	—	—	—	—
2198-DSM016-ERSx-B1303C	2250	39.0	—	29.0	24.0	—	20.0 *	—	—	—	—	—	—	—	—	—
2198-DSM024-ERSx-B1303F	4000	—	—	29.0	—	21.0	—	18.0 *	—	16.0	—	—	—	—	—	—
2198-DSM016-ERSx-B1304C	2150	43.0	—	32.0	27.0 *	—	23.0 *	—	—	—	—	—	—	—	—	—
2198-DSM024-ERSx-B1304E	3500	—	—	32.0	27.0	—	22.0 *	—	18.0	—	—	—	—	—	—	—
2198-DSM024-ERSx-B1306C	2500	48.0	—	36.0	—	29.0 *	24.0	—	—	—	—	—	—	—	—	—

(1) 1.0 kgf = 2.2 lbf or 9.8 N. An asterisk (\*) indicates a load rating measured at an rpm value that is less than the value listed for that column.

Axial Load Force Ratings (zero radial load) for Non-brake Motors

Motor Cat. No. (1)	Maximum Speed rpm	Load (kgf) at Speed (rpm)														
		500 kgf	750 kgf	1000 kgf	1500 kgf	2000 kgf	2500 kgf	3000 kgf	3500 kgf	4000 kgf	4500 kgf	5000 kgf	5500 kgf	6000 kgf	6500 kgf	7000 kgf
2198-DSM016-ERSx-A1001C	2800	49.4	—	36.5	—	27.0	—	23.4 *	—	—	—	—	—	—	—	—
2198-DSM016-ERSx-A1002C	3000	49.4	—	36.5	—	27.0	—	22.7	—	—	—	—	—	—	—	—
2198-DSM024-ERSx-A1003C	2250	49.4	—	36.5	30.6	—	25.7 *	—	—	—	—	—	—	—	—	—
2198-DSM024-ERSx-A1003E	3750	49.4	—	36.5	—	27.0	—	—	—	20.6 *	—	—	—	—	—	—
2198-DSM016-ERSx-A1152B	2150	68.3	—	50.5	42.4	—	36.0 *	—	—	—	—	—	—	—	—	—
2198-DSM024-ERSx-A1152E	3300	68.3	—	50.5	—	37.4	—	—	30.1 *	—	—	—	—	—	—	—
2198-DSM024-ERSx-A1153A	1600	68.3	—	50.5	—	37.4	—	—	—	—	—	—	—	—	—	—
2198-DSM024-ERSx-A1153C	2300	68.3	—	50.5	42.4	—	35.2 *	—	—	—	—	—	—	—	—	—
2198-DSM016-ERSx-A1303A	1150	68.3	—	50.5	42.4	41.2 *	—	—	—	—	—	—	—	—	—	—
2198-DSM024-ERSx-A1303B	1950	68.3	—	50.5	42.4	37.8 *	—	—	—	—	—	—	—	—	—	—
2198-DSM024-ERSx-A1304A	3000	68.3	—	50.5	—	37.4	—	31.4	—	—	—	—	—	—	—	—
2198-DSM024-ERSx-A1306A	1250	68.3	—	50.5	42.4	—	—	—	—	—	—	—	—	—	—	—
2198-DSM016-ERSx-B1001M	6000	—	—	—	—	27.0	—	22.7	—	20.0	—	—	—	16.8	—	—
2198-DSM016-ERSx-B1002M	6000	—	—	—	30.6	—	—	22.7	—	—	19.0	—	—	16.8	—	—
2198-DSM024-ERSx-B1003F	4750	—	—	36.5	30.6	—	—	22.7	—	—	—	18.6 *	—	—	—	—
2198-DSM024-ERSx-B1003T	7000	—	—	—	30.6	—	—	24.5	—	—	—	19.0	—	—	—	15.7
2198-DSM016-ERSx-B1152F	4000	—	—	50.5	—	37.4	—	31.4	—	—	26.3	—	—	—	—	—
2198-DSM024-ERSx-B1152T	6500	—	—	—	42.4	—	—	33.9	—	—	27.7	—	—	—	22.4	—
2198-DSM024-ERSx-B1153E	3200	68.3	—	50.5	—	37.4	—	—	30.5 *	—	—	—	—	—	—	—
2198-DSM024-ERSx-B1153F	5000	—	—	50.5	—	37.4	—	31.4	—	—	—	25.1	—	—	—	—
2198-DSM016-ERSx-B1303C	2250	68.3	—	50.5	42.3	—	—	35.5 *	—	—	—	—	—	—	—	—
2198-DSM024-ERSx-B1303F	4000	—	—	50.5	—	37.4	—	31.8 *	—	—	27.7	—	—	—	—	—
2198-DSM016-ERSx-B1304C	2150	68.3	—	50.5	43.6 *	—	—	36.2 *	—	—	—	—	—	—	—	—
2198-DSM024-ERSx-B1304E	3500	—	—	50.5	42.4	—	—	35.2 *	—	—	29.3	—	—	—	—	—
2198-DSM024-ERSx-B1306C	2500	68.3	—	50.5	—	—	—	40.6 *	33.9	—	—	—	—	—	—	—

(1) 1.0 kgf = 2.2 lbf or 9.8 N. An asterisk (\*) indicates a load rating measured at an rpm value that is less than the value listed for that column.



Radial Load Force Ratings (maximum) for Brake Motors

Motor Cat. No. (1)	Maximum Speed rpm	Load (kgf) at Speed (rpm)														
		500 kgf	750 kgf	1000 kgf	1500 kgf	2000 kgf	2500 kgf	3000 kgf	3500 kgf	4000 kgf	4500 kgf	5000 kgf	5500 kgf	6000 kgf	6500 kgf	7000 kgf
2198-DSM016-ERSx-A1001C	2800	90.2	—	71.6	—	56.8	—	50.8 *	—	—	—	—	—	—	—	—
2198-DSM016-ERSx-A1002C	3000	95.3	—	75.6	—	60.0	—	52.4	—	—	—	—	—	—	—	—
2198-DSM024-ERSx-A1003C	2250	99.0	—	78.5	68.6	—	59.9 *	—	—	—	—	—	—	—	—	—
2198-DSM024-ERSx-A1003E	3750	99.0	—	78.5	—	62.3	—	—	—	50.6 *	—	—	—	—	—	—
2198-DSM016-ERSx-A1152B	2150	111.3	—	88.4	77.2	—	68.5 *	—	—	—	—	—	—	—	—	—
2198-DSM024-ERSx-A1152E	3300	111.3	—	88.4	—	70.1	—	—	59.4 *	—	—	—	—	—	—	—
2198-DSM024-ERSx-A1153A	1600	115.4	—	91.6	—	72.7	—	—	—	—	—	—	—	—	—	—
2198-DSM024-ERSx-A1153C	2300	115.4	—	91.6	80.0	—	69.4 *	—	—	—	—	—	—	—	—	—
2198-DSM016-ERSx-A1303A	1150	145.3	—	115.3	100.7	—	—	—	—	—	—	—	—	—	—	—
2198-DSM024-ERSx-A1303B	1950	145.3	—	115.3	100.7	92.3 *	—	—	—	—	—	—	—	—	—	—
2198-DSM024-ERSx-A1304A	1600	149.7	130.8	119.8 *	—	101.6 *	—	—	—	—	—	—	—	—	—	—
2198-DSM024-ERSx-A1306A	1250	156.0	—	123.8	108.19	—	—	—	—	—	—	—	—	—	—	—
2198-DSM016-ERSx-B1001M	6000	—	—	—	—	56.8	—	49.6	—	45.1	—	—	—	39.4	—	—
2198-DSM016-ERSx-B1002M	6000	—	—	—	66.1	—	—	52.4	—	—	45.8	—	—	41.6	—	—
2198-DSM024-ERSx-B1003F	4750	—	—	78.5	68.6	—	—	54.5	—	—	—	46.7 *	—	—	—	—
2198-DSM024-ERSx-B1003T	7000	—	—	—	68.6	—	—	57.9	—	—	—	47.6	—	—	—	41.1
2198-DSM016-ERSx-B1152F	4000	—	—	88.4	—	70.1	—	61.3	—	—	53.5	—	—	—	—	—
2198-DSM024-ERSx-B1152T	6500	—	—	—	77.2	—	—	65.1	—	—	55.7	—	—	—	47.4	—
2198-DSM024-ERSx-B1153E	3200	115.4	—	91.6	—	72.7	—	—	62.2 *	—	—	—	—	—	—	—
2198-DSM024-ERSx-B1153F	5000	—	—	91.6	—	72.7	—	63.5	—	—	—	53.6	—	—	—	—
2198-DSM016-ERSx-B1303C	2250	145.3	—	115.3	100.7	—	—	88.0 *	—	—	—	—	—	—	—	—
2198-DSM024-ERSx-B1303F	4000	—	—	115.3	—	91.5	—	80.9 *	—	—	72.7	—	—	—	—	—
2198-DSM016-ERSx-B1304C	2150	149.7	—	118.8	106.2 *	—	—	92.0 *	—	—	—	—	—	—	—	—
2198-DSM024-ERSx-B1304E	3500	—	—	118.8	103.8	—	—	90.0 *	—	—	78.2	—	—	—	—	—
2198-DSM024-ERSx-B1306C	2500	156.0	—	123.8	—	104.8 *	91.2	—	—	—	—	—	—	—	—	—

(1) 1.0 kgf = 2.2 lbf or 9.8 N. An asterisk (\*) indicates a load rating measured at an rpm value that is less than the value listed for that column.

**Axial Load Force Ratings (maximum radial load) for Brake Motors**

Motor Cat. No. (1)	Maximum Speed rpm	Load (kgf) at Speed (rpm)														
		500 kgf	750 kgf	1000 kgf	1500 kgf	2000 kgf	2500 kgf	3000 kgf	3500 kgf	4000 kgf	4500 kgf	5000 kgf	5500 kgf	6000 kgf	6500 kgf	7000 kgf
2198-DSM016-ERSx-A1001C	2800	31.0	—	23.0	—	17.0	—	14.0 *	—	—	—	—	—	—	—	—
2198-DSM016-ERSx-A1002C	3000	34.0	—	25.0	—	18.0	—	15.0	—	—	—	—	—	—	—	—
2198-DSM024-ERSx-A1003C	2250	36.0	—	26.0	22.0	—	18.0 *	—	—	—	—	—	—	—	—	—
2198-DSM024-ERSx-A1003E	3750	36.0	—	26.0	—	19.0	—	—	—	15.0 *	—	—	—	—	—	—
2198-DSM016-ERSx-A1152B	2150	50.0	—	37.0	31.0	—	26.0 *	—	—	—	—	—	—	—	—	—
2198-DSM024-ERSx-A1152E	3300	51.0	—	37.0	—	27.0	—	—	22.0 *	—	—	—	—	—	—	—
2198-DSM024-ERSx-A1153A	1600	53.0	—	39.0	—	29.0	—	—	—	—	—	—	—	—	—	—
2198-DSM024-ERSx-A1153C	2300	53.0	—	39.0	32.0	—	27.0 *	—	—	—	—	—	—	—	—	—
2198-DSM016-ERSx-A1303A	1150	46.0	—	34.0	28.0	—	—	—	—	—	—	—	—	—	—	—
2198-DSM024-ERSx-A1303B	1950	46.0	—	34.0	28.0	25.0 *	—	—	—	—	—	—	—	—	—	—
2198-DSM024-ERSx-A1304A	1600	48.0	40.0	36.0 *	—	29.0 *	—	—	—	—	—	—	—	—	—	—
2198-DSM024-ERSx-A1306A	1250	52.0	—	38.0	32.0	—	—	—	—	—	—	—	—	—	—	—
2198-DSM016-ERSx-B1001M	6000	—	—	—	—	17.0	—	14.0	—	12.0	—	—	—	10.0	—	—
2198-DSM016-ERSx-B1002M	6000	—	—	—	21.0	—	—	15.0	—	—	13.0	—	—	11.0	—	—
2198-DSM024-ERSx-B1003F	4750	—	—	26.0	22.0	—	—	16.0	—	—	—	13.0 *	—	—	—	—
2198-DSM024-ERSx-B1003T	7000	—	—	—	22.0	—	—	18.0	—	—	—	13.0	—	—	—	11.0
2198-DSM016-ERSx-B1152F	4000	—	—	37.0	—	27.0	—	23.0	—	—	19.0	—	—	—	—	—
2198-DSM024-ERSx-B1152T	6500	—	—	—	31.0	—	—	25.0	—	—	20.0	—	—	—	16.0	—
2198-DSM024-ERSx-B1153E	3200	53.0	—	39.0	—	29.0	—	—	23.0*	—	—	—	—	—	—	—
2198-DSM024-ERSx-B1153F	5000	—	—	39.0	—	29.0	—	24.0	—	—	—	19.0	—	—	—	—
2198-DSM016-ERSx-B1303C	2250	46.0	—	34.0	28.0	—	—	24.0 *	—	—	—	—	—	—	—	—
2198-DSM024-ERSx-B1303F	4000	—	—	34.0	—	25.0	—	21.0 *	—	—	18.0	—	—	—	—	—
2198-DSM016-ERSx-B1304C	2150	48.0	—	36.0	31.0 *	—	—	25.0 *	—	—	—	—	—	—	—	—
2198-DSM024-ERSx-B1304E	3500	—	—	36.0	30.0	—	—	25.0 *	—	20.0	—	—	—	—	—	—
2198-DSM024-ERSx-B1306C	2500	52.0	—	38.0	—	31.0 *	—	25.0	—	—	—	—	—	—	—	—

(1) 1.0 kgf = 2.2 lbf or 9.8 N. An asterisk (\*) indicates a load rating measured at an rpm value that is less than the value listed for that column.

**Axial Load Force Ratings (zero radial load) for Brake Motors**

Motor Cat. No. (1)	Maximum Speed rpm	Load (kgf) at Speed (rpm)														
		500 kgf	750 kgf	1000 kgf	1500 kgf	2000 kgf	2500 kgf	3000 kgf	3500 kgf	4000 kgf	4500 kgf	5000 kgf	5500 kgf	6000 kgf	6500 kgf	7000 kgf
2198-DSM016-ERSx-A1001C	2800	49.4	—	36.5	—	27.0	—	23.4 *	—	—	—	—	—	—	—	—
2198-DSM016-ERSx-A1002C	3000	49.4	—	36.5	—	27.0	—	22.7	—	—	—	—	—	—	—	—
2198-DSM024-ERSx-A1003C	2250	49.4	—	36.5	30.6	—	25.7 *	—	—	—	—	—	—	—	—	—
2198-DSM024-ERSx-A1003E	3750	49.4	—	36.5	—	27.0	—	—	—	20.6 *	—	—	—	—	—	—
2198-DSM016-ERSx-A1152B	2150	68.3	—	50.5	42.4	—	36.2 *	—	—	—	—	—	—	—	—	—
2198-DSM024-ERSx-A1152E	3300	68.3	—	50.5	—	37.4	—	—	30.1 *	—	—	—	—	—	—	—
2198-DSM024-ERSx-A1153A	1600	68.3	—	50.5	—	37.4	—	—	—	—	—	—	—	—	—	—
2198-DSM024-ERSx-A1153C	2300	68.3	—	50.5	42.4	—	35.2 *	—	—	—	—	—	—	—	—	—
2198-DSM016-ERSx-A1303A	1150	68.3	—	50.5	42.4	—	—	—	—	—	—	—	—	—	—	—
2198-DSM024-ERSx-A1303B	1950	68.3	—	50.5	42.4	37.8 *	—	—	—	—	—	—	—	—	—	—
2198-DSM024-ERSx-A1304A	1600	68.3	57.2	51.1 *	—	41.2 *	—	—	—	—	—	—	—	—	—	—
2198-DSM024-ERSx-A1306A	1250	68.3	—	50.5	42.4	—	—	—	—	—	—	—	—	—	—	—
2198-DSM016-ERSx-B1001M	6000	—	—	—	—	27.0	—	22.7	—	20.0	—	—	—	16.8	—	—
2198-DSM016-ERSx-B1002M	6000	—	—	—	30.6	—	—	22.7	—	—	19.0	—	—	16.8	—	—
2198-DSM024-ERSx-B1003F	4750	—	—	36.5	30.6	—	—	22.7	—	—	—	18.6 *	—	—	—	—
2198-DSM024-ERSx-B1003T	7000	—	—	—	30.6	—	24.5	—	—	—	19.0	—	—	—	—	15.7
2198-DSM016-ERSx-B1152F	4000	—	—	50.5	—	37.4	—	31.4	—	—	26.3	—	—	—	—	—
2198-DSM024-ERSx-B1152T	6500	—	—	—	42.4	—	33.9	—	—	27.7	—	—	—	—	22.4	—
2198-DSM024-ERSx-B1153E	3200	68.3	—	50.5	—	37.4	—	—	30.5 *	—	—	—	—	—	—	—
2198-DSM024-ERSx-B1153F	5000	—	—	50.5	—	37.4	—	31.4	—	—	—	25.1	—	—	—	—
2198-DSM016-ERSx-B1303C	2250	68.3	—	50.5	42.4	—	35.5 *	—	—	—	—	—	—	—	—	—
2198-DSM024-ERSx-B1303F	4000	—	—	50.5	—	37.4	—	31.8 *	—	27.7	—	—	—	—	—	—
2198-DSM016-ERSx-B1304C	2150	68.3	—	50.5	43.6 *	—	36.2 *	—	—	—	—	—	—	—	—	—
2198-DSM024-ERSx-B1304E	3500	—	—	50.5	42.4	—	35.2 *	—	29.3	—	—	—	—	—	—	—
2198-DSM024-ERSx-B1306C	2500	68.3	—	50.5	—	40.6 *	33.9	—	—	—	—	—	—	—	—	—

(1) 1.0 kgf = 2.2 lbf or 9.8 N. An asterisk (\*) indicates a load rating measured at an rpm value that is less than the value listed for that column.

## Circuit Breaker/Fuse Specifications

The 2198-PIM070 module uses internal fuses for short-circuit protection of the DC bus. The recommended fuse is Bussmann FWP-50A14Fa. The Kinetix 5700 drives use internal solid-state motor short-circuit protection and, when protected by suitable branch circuit protection, are rated for use on a circuit capable of delivering up to 200,000 A (fuses) and 65,000 A (circuit breakers).

### DC-bus Power Supply UL/CSA Circuit-protection Specifications

DC-bus Power Supply Cat. No.	Input Voltage (three-phase) nom	Bussmann Fuses <sup>(1)</sup> Cat. No.	Miniature CB <sup>(2)</sup> Cat. No.	Motor Protection CB, <sup>(2) (3)</sup> Self Protected CMC Cat. No.	Molded Case CB Cat. No.
2198-P031	195...528V AC	LPJ-15SP (15 A)	1489-M3D250	140M-D8E-C25 140MT-D9E-C25	140G-G6C3-C25
2198-P070		LPJ-40SP (40 A)	N/A	140M-F8E-C45	140G-G6C3-C50
2198-P141		LPJ-70SP (70 A)	N/A	N/A	140G-G6C3-C90
2198-P208		LPJ-100SP (100 A)	N/A	N/A	140G-G6C3-D12

(1) For applications requiring CSA certification, fuses (Bussmann catalog number 170M1760) must be added to the DC link between the two drive clusters when circuit breakers are used for branch circuit protection. The DC bus fuses are not required when AC line fuses are used for branch circuit protection.

(2) These Bulletin 140M/MT Motor Protection Circuit Breakers, when used as self-protected (Type E) devices, and Bulletin 1489 circuit breakers can be used on only WYE power systems (480Y/277V).

(3) The AIC ratings of the Bulletin 140M/MT devices can vary. See publication [140-TD005](#) or [140M-TD002](#).

### DC-bus Power Supply IEC (non-UL/CSA) Circuit-protection Specifications

DC-bus Power Supply Cat. No.	Input Voltage (three-phase) nom	DIN gG Fuses Amps, max	Miniature CB Cat. No.		Motor Protection CB Cat. No. <sup>(1)</sup>	Molded Case CB Cat. No.
2198-P031	195...528V AC	16	1489-M3D250	N/A	140M-D8E-C25 140MT-D9E-C25	140G-G6C3-C25
2198-P070		40	N/A	1482-SPM3D400	140M-F8E-C45	140G-G6C3-C50
2198-P141		75	N/A	1482-SPM3D630	140MG-H8E-C60	140G-G6C3-C90
2198-P208		110	N/A	N/A	140MG-H8E-D10	140G-G6C3-D12

(1) The AIC ratings of the Bulletin 140M/MT devices can vary. See publication [140-TD005](#) or [140M-TD002](#).

## Contactors Specifications

The DC-bus power supply contactor enable relay (CED connector) is rated at 24V DC and 1.0 A, max.

### DC-bus Power Supply Contactor Specifications

DC-bus Power Supply Cat. No.	Contactor <sup>(1) (2)</sup> Cat. No.	Intermediate Relay <sup>(3)</sup> Cat. No.
2198-P031	100-C16EJ10	N/A
2198-P070	100-C37EJ10	
2198-P141	100-C72DJ10	
2198-P208	100-C97DJ10	700-HB32Z24 (relay) 700-HN153 (socket)
2198-P208 (2 in parallel)	100-E190KJ11	
2198-P208 (3 in parallel)	100-E305KJ11	

(1) Auxiliary contact configuration (10) is for 1 = N.O. or 0 = N.C. Other configurations are available.

(2) For contactors that are not Bulletin 100-E type, the integrated diode is required with the contactor coil.

(3) These DC-bus power supplies require an additional intermediate relay used with the contactor.

## Power Dissipation Specifications

Use this table to size an enclosure and calculate required ventilation for your Kinetix 5700 drive system, which includes the PIM module.

### Power Dissipation Specifications - Percent of PIM Module Control Power

Control Power Input	Power Dissipation as % of PIM Module Control Power Output Rating Watts <sup>(1)</sup>					Heat Dissipation Formulas <sup>(2)</sup>
	20%	40%	60%	80%	100%	
Input Voltage DC						
24V	10	15	19	24	29	$Y = 23.5x + 5.3$

(1) Power output rating of 100% is 4 A at 58V output (applicable when 3-phase is not present).

(2) The x is percent of PIM module control power output rating; any value from 0.0...1.0.

## Weight Specifications

Attribute	PIM	DSD	DSM			
			Frame 75	Frame 100	Frame 115	Frame 130
Weight, kg (lb) approx	1.98 kg (4.37 lb)	2.10 kg (4.63 lb)	2.50...5.00 kg (5.51...11.02 lb)	4.00...7.00 kg (8.81...15.43 lb)	5.50...8.50 kg (12.13...18.74 lb)	8.50...15.00 kg (18.74...33.07 lb)

## Maximum Cable Lengths

When sizing your system, note the following:

- Maximum cable length between the PIM module and a DSx module is 50 m (164 ft).
- Maximum cable length between DSx modules is 30 m (98 ft).
- Maximum power cable length between a DSD module and a motor is 4 m (13 ft).
- Maximum feedback cable length between a DSD module and a motor is 4 m (13 ft).
- Combined cable length for all ArmorKinetix modules that are connected to one PIM module is 140 m (459 ft).

See the Kinetix Rotary and Linear Motion Cable Specifications Technical Data, publication [KNX-TD004](#), for cable specifications.

**IMPORTANT** For more information on maximum motor cable lengths, see the ArmorKinetix System User Manual, publication [2198-UM006](#).

**IMPORTANT** System performance was tested at these cable lengths. These limitations also apply when meeting CE and UK requirements.

# Dimensions - ArmorKinetix System Modules

These drawings provide mounting dimensions for ArmorKinetix PIM, DSD, and DSM modules.

## DSM Module Dimensions

### DSM Module Dimensions, 75 mm Frame Size

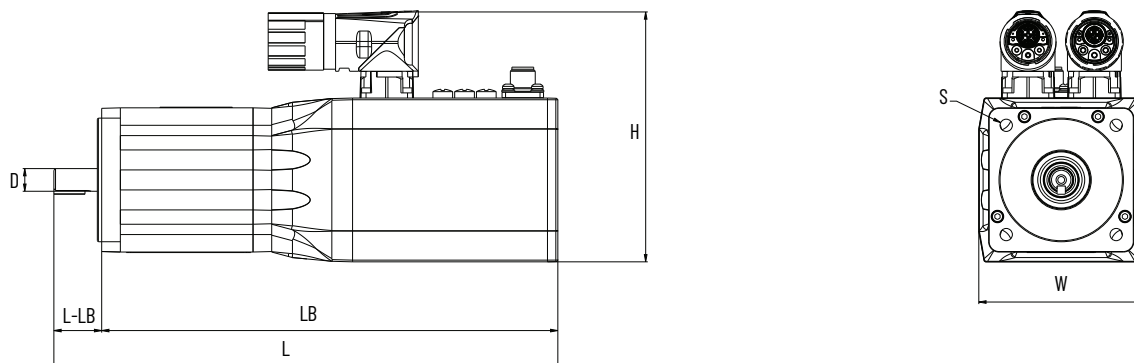

DSM Module Dimensions Table, 75 mm Frame Size

Cat. No.	L mm (in.)	LB mm (in.)	L-LB mm (in.)	H mm (in.)	W mm (in.)	D mm (in.)	S mm (in.)
2198-DSMxxx-ERSx-x0751 without brake	244.8 (9.64)	221.8 (8.73)	23.0 (0.91)	121.9 (4.80)	79.5 (3.13)	11.0 (0.43)	5.95 (0.23)
2198-DSMxxx-ERSx-x0751 with brake	275.4 (10.84)	252.4 (9.94)					
2198-DSMxxx-ERSx-x0752 without brake	269.8 (10.62)	246.8 (9.72)					
2198-DSMxxx-ERSx-x0752 with brake	300.4 (11.83)	277.4 (10.92)					
2198-DSMxxx-ERSx-x0753 without brake	294.8 (11.61)	271.8 (10.70)					
2198-DSMxxx-ERSx-x0753 with brake	325.4 (12.81)	302.4 (11.91)					

### DSM Module Dimensions, 100 mm Frame Size

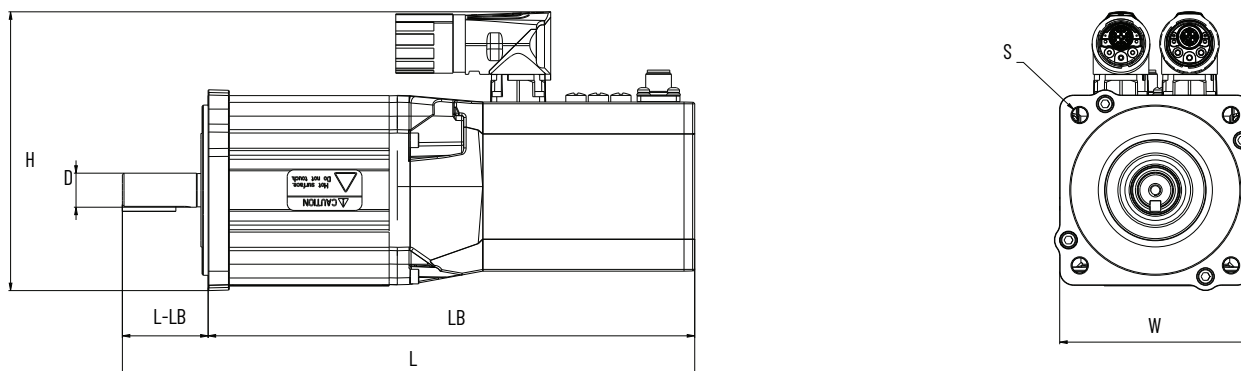

DSM Module Dimensions Table, 100 mm Frame Size

STACK SIZE	L mm (in.)	LB mm (in.)	L-LB mm (in.)	H mm (in.)	W mm (in.)	D mm (in.)	S mm (in.)
2198-DSMxxx-ERSx-x1001 without brake	269.7 (10.62)	229.7 (9.04)	40.0 (1.57)	126.4 (4.98)	89.4 (3.52)	16.0 (0.63)	7.2 (0.28)
2198-DSMxxx-ERSx-x1001 with brake	304.2 (11.98)	264.2 (10.40)					
2198-DSMxxx-ERSx-x1002 without brake	295.1 (11.62)	255.1 (10.04)					
2198-DSMxxx-ERSx-x1002 with brake	329.6 (12.98)	289.6 (11.40)					
2198-DSMxxx-ERSx-x1003 without brake	320.5 (12.62)	280.5 (11.04)					
2198-DSMxxx-ERSx-x1003 with brake	355.0 (13.98)	315.0 (12.40)					

**DSM Module Dimensions, 115 mm Frame Size**

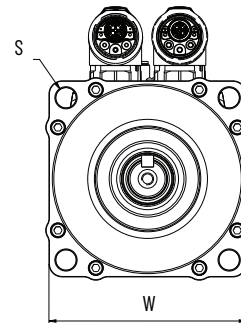
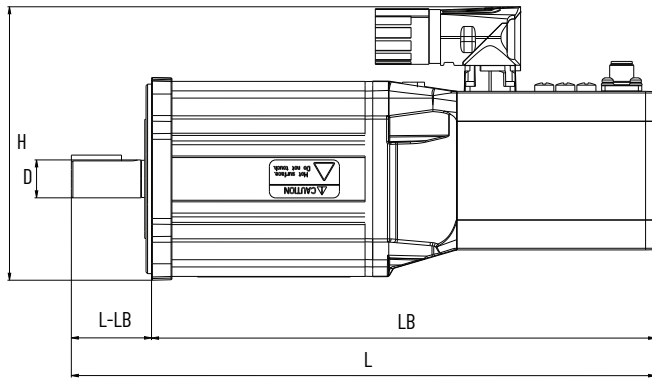

**DSM Module Dimensions Table, 115 mm Frame Size**

STACK SIZE	L mm (in.)	LB mm (in.)	L-LB mm (in.)	H mm (in.)	W mm (in.)	D mm (in.)	S mm (in.)
2198-DSMxxx-ERSx-x1152 without brake	291.5 (11.48)	251.5 (9.90)	40.0 (1.57)	137.1 (5.40)	98.3 (3.87)	19.0 (0.75)	10.2 (0.40)
2198-DSMxxx-ERSx-x1152 with brake	340.0 (13.39)	300.0 (11.81)					
2198-DSMxxx-ERSx-x1153 without brake	316.9 (12.48)	276.9 (10.90)					
2198-DSMxxx-ERSx-x1153 with brake	365.4 (14.39)	325.4 (12.81)					

**DSM Module Dimensions, 130 mm Frame Size**

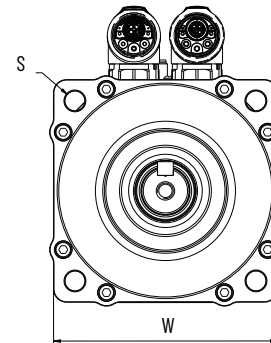
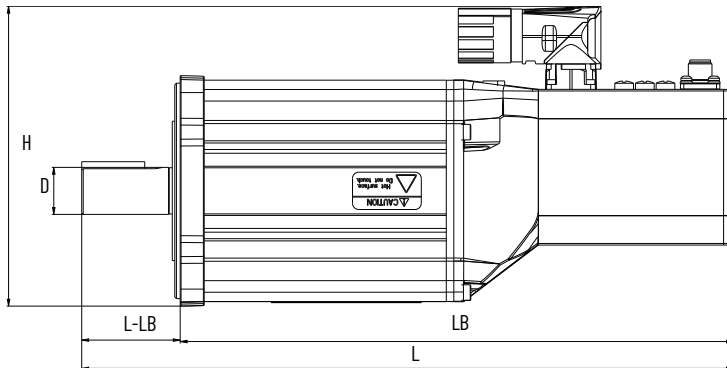

**DSM Module Dimensions Table, 130 mm Frame Size**

STACK SIZE	L mm (in.)	LB mm (in.)	L-LB mm (in.)	H mm (in.)	W mm (in.)	D mm (in.)	S mm (in.)
2198-DSMxxx-ERSx-x1303 without brake	330.2 (13.00)	280.2 (11.03)	50.0 (1.97)	153.1 (6.03)	113.7 (4.48)	24.0 (0.94)	10.2 (0.40)
2198-DSMxxx-ERSx-x1303 with brake	378.7 (14.91)	328.7 (12.94)					
2198-DSMxxx-ERSx-x1304 without brake	355.6 (14.00)	305.6 (12.03)					
2198-DSMxxx-ERSx-x1304 with brake	404.1 (15.91)	354.1 (13.94)					
2198-DSMxxx-ERSx-x1306 without brake	406.4 (16.00)	356.4 (14.03)					
2198-DSMxxx-ERSx-x1306 with brake	454.9 (17.91)	404.9 (15.94)					

## DSD Module Dimensions

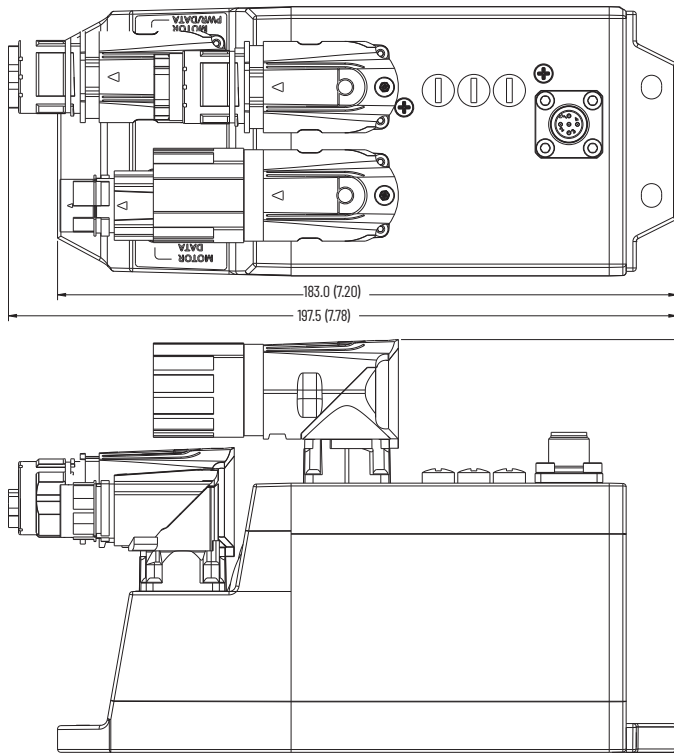

Dimensions are in mm (in.)

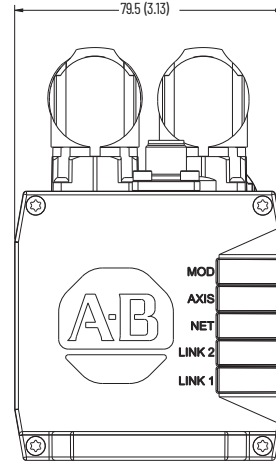

## PIM Module Dimensions

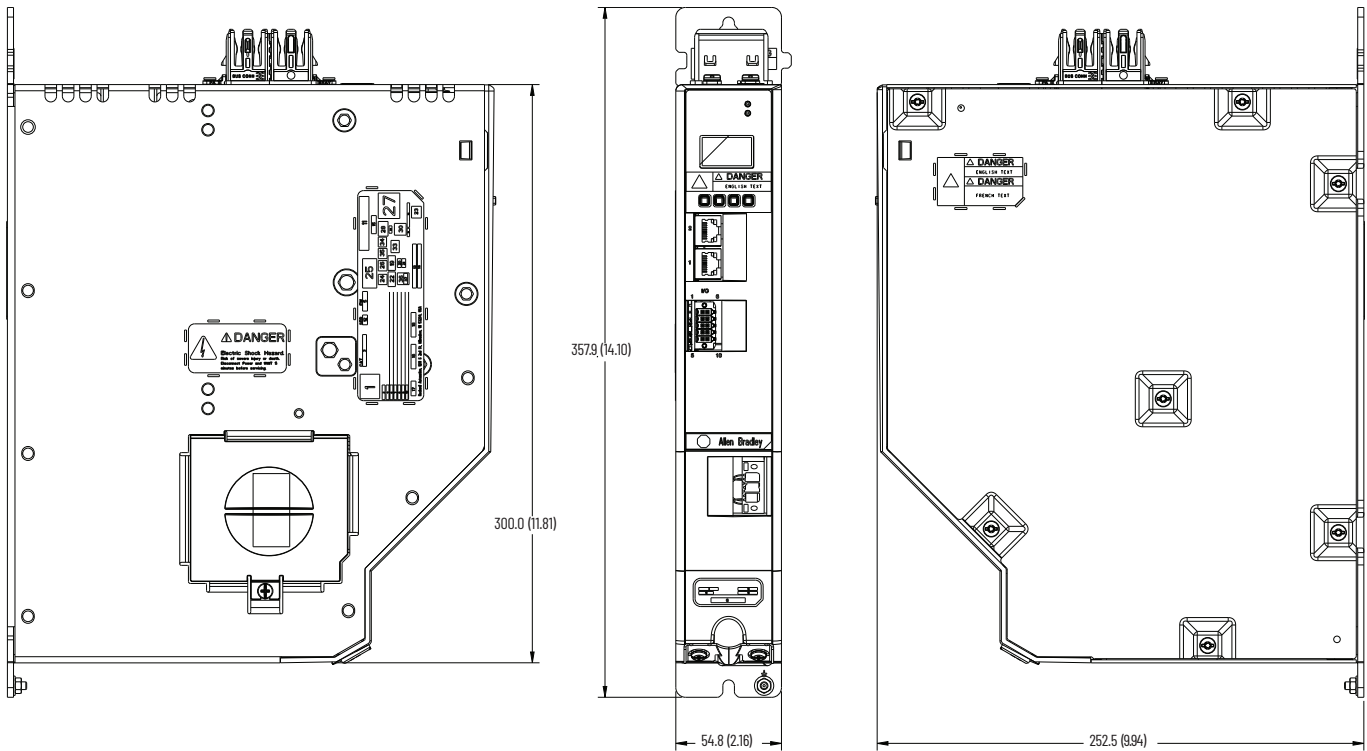



## Environmental Specifications - ArmorKinetix System Modules

Attribute	PIM	DSD	DSM			
			Frame 75	Frame 100	Frame 115	Frame 130
Surrounding air temperature Operating (with de-rating) Storage	0...50 °C (32...122 °F) — -40...+70 °C (-40...+158 °F)	-10...+40 °C (14...104 °F) (-20...+55 °C [-4...131 °F]) -40...+85 °C (-40...+185 °F)	-10...+40 °C (14...104 °F) (-20...+55 °C [-4...131 °F]) -40...+85 °C (-40...+185 °F)			
Relative humidity	5...95% noncondensing					
IP rating	IP20	IP66 and IP67	IP50 (without shaft seal), IP66, IP67 (with shaft seal)			
UL Type	—	Type 1	Type 1			
Vibration	5...55 Hz @ 0.35 mm (0.014 in.) double amplitude, continuous displacement; 55...500 Hz @ 2.0 g peak constant acceleration	5...9 Hz @ 0.3 mm (0.012 in.) double amplitude, continuous displacement; 9...500 Hz @ 5.0g, 500 Hz...2000 Hz @ 2.5g peak constant acceleration				
Shock	15 g, 11 ms half-sine pulse (3 pulses in each direction of 3 mutually perpendicular directions)	25 g, 6 ms half-sine pulse (3 pulses in each direction of 3 mutually perpendicular directions)				
Short-circuit current rating	50 kA max. rms symmetrical					
Branch circuit short circuit protection	Integral solid-state short circuit protection does not provide branch circuit protection. Branch circuit protection must be provided in accordance with the National Electric Code (NEC) and any additional local codes.					

## Certifications - ArmorKinetix System Modules

Rating	PIM	DSD	DSM
UL	UL61800-5-1 second edition NMMS:E59272		
CE	LV Directive 2014/35/EU, EMC Directive 2014/30/EU, Machinery Directive 2006/42/EC, RoHS Directive 2011/65/EU		
Functional Safety	—	TÜV Certified for Functional Safety: up to SIL CL3, according to IEC 61800-5-2, IEC 61508, and IEC 62061; up to Performance Level PL <sub>e</sub> and Category 3, according to ISO 13849-1; when used as described in the ArmorKinetix System User Manual, publication <a href="#">2198-UM006</a> or the Kinetix 5700 Safe Monitor Functions Safety Reference Manual, publication <a href="#">2198-RM007</a>	For STO and SS1: TÜV Certified for Functional Safety: up to SIL CL3, according to IEC 61800-5-2, IEC 61508, and IEC 62061; up to Performance Level PL <sub>e</sub> and Category 3, according to ISO 13849-1; when used as described in the ArmorKinetix System User Manual, publication <a href="#">2198-UM006</a> or the Kinetix 5700 Safe Monitor Functions Safety Reference Manual, publication <a href="#">2198-RM007</a>  For Monitoring Function: TÜV Certified for Functional Safety: up to SIL CL2, according to IEC 61800-5-2, IEC 61508, and IEC 62061; up to Performance Level PL <sub>d</sub> and Category 3, according to ISO 13849-1; when used as described in the ArmorKinetix System User Manual, publication <a href="#">2198-UM006</a> or the Kinetix 5700 Safe Monitor Functions Safety Reference Manual, publication <a href="#">2198-RM007</a>
KCC	Korean Registration of Broadcasting and Communications Equipment, compliant with: KCC-REM-RAA-2198   KCC-REM-RAA-2198		R-R-RAA-DSM
Regulatory compliance mark (RCM)	Radiocommunications Act:1992 (including Amendments up to 2018) Radiocommunications (Electromagnetic Compatibility) Standard 2017 Radiocommunications Labeling (Electromagnetic Compatibility) Notice 2017		
UKCA	2016 No. 1101 Electrical Equipment (Safety) Regulations (LV) 2016 No. 1091 Electromagnetic Compatibility Regulations (EMC) 2008 No. 1597 Supply of Machinery (Safety) Regulations (MD) 2012 No. 3032 Restriction of the Use of Certain Hazardous Substances in Electrical and Electronic Equipment Regulations (RoHS)		
Morocco	Arrêtémministériel n° 6404-15 du 1 ermuharram 1437 (15 octobre 2015) Arrêtémministériel n° 6404-15 du 29 ramadan 1436 (16 juillet 2015)		
ODVA	<ul style="list-style-type: none"> <li>EtherNet/IP conformance tested</li> <li>CIP Security™ conformance tested</li> </ul>		
Ecodesign	Ecodesign Directive 2009/125/EC as implemented by Commission Regulation (EU) 2019/1781		

## Accessories - ArmorKinetix System Modules

ArmorKinetix system accessories include the accessory modules, passive shunt modules, the encoder output module, line reactors, AC line filters, the system mounting toolkit, and shared-bus connector kits. See [Accessories - Kinetix 5700 Servo Drives on page 28](#) for available accessories.

- Accessory Modules
- Passive Shunt Modules and Resistors
- Bulletin 1321 Line Reactors
- AC Line Filters - See [AC Line Filter Dimensions and Specifications on page 138](#) for product dimensions and additional specifications.
- DC-bus Link Connector Kits

### DC-bus Link Connector Kit Catalog Numbers

Replacement Kit Cat. No.	Description	Module Type	Module Cat. No.	Illustration
2198-BARCON-55DC200	DC-bus link, 55 mm, 208 A	PIM module	2198-PIM070	

- System Mounting Toolkit
- External Auxiliary Encoders

## Replacement Parts and Connector Kits - ArmorKinetix System

Replacement parts and kits available for ArmorKinetix system modules include the power-sharing bus-bars and power connector sets.

### Power Sharing Bus-bars and Connector Sets

#### Replacement Power Sharing Bus-bars

Replacement Kit Cat. No.	Description	Module Type	Module Cat. No.	Illustration
2198-BARCON-55DCAC100	Bus-bar connectors, 55 mm, quantity 8	DC-bus power supplies	2198-P031, 2198-P070	
		ArmorKinetix PIM	2198-PIM070	
		Capacitor module	2198-CAPMOD-2240	
		DC-bus conditioner module	2198-DCBUSCOND-RP312	

#### Replacement Connector Sets

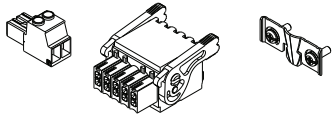
Replacement Kit Cat. No.	Description	Module Type	Module Cat. No.	Illustration
2198-KITCON-PIM070	One 24V control power connector One digital input connector One hybrid cable clamp	ArmorKinetix PIM	2198-PIM070	

# Kinetix 5500 Servo Drives



The Kinetix 5500 servo drives and Kinetix VP servo motors provide a cost-effective motion solution that delivers high performance and scalability with motor windings matched to drive ratings for optimized system sizing.

Enhancing the current midrange architecture portfolio, this motion system is designed to connect and operate with the ControlLogix, GuardLogix, and CompactLogix controllers by using the Studio 5000 Logix Designer application and supporting integrated motion and safety on the EtherNet/IP network. With the benefits of this motion system, you can now run motion applications on a single control platform by using a single network, simplifying the design, operation, and maintenance of equipment.

## Kinetix 5500 Drive Features and Indicators

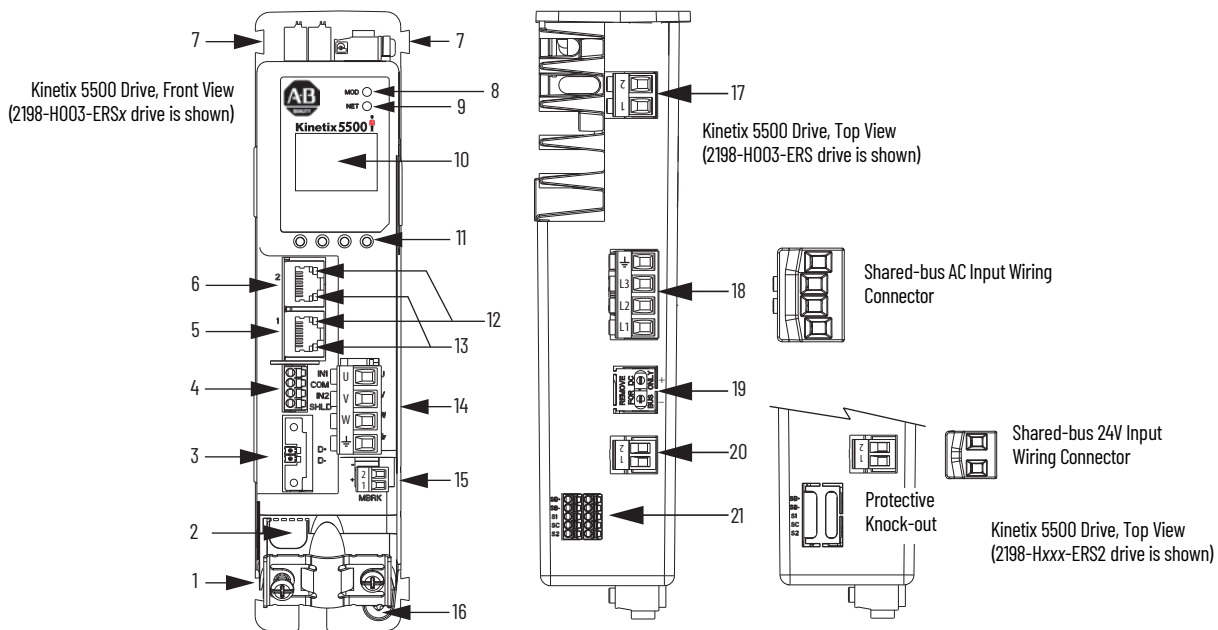

Item	Description
1	Motor cable shield clamp
2	Converter kit mounting hole <sup>(1)</sup> (under cover)
3	Motor feedback (MF) connector
4	Digital inputs (IOD) connector
5	Ethernet (PORT1) RJ45 connector
6	Ethernet (PORT2) RJ45 connector
7	Zero-stack mounting tab/cutout

Item	Description
8	Module status indicator
9	Network status indicator
10	LCD display
11	Navigation pushbuttons
12	Link speed status indicators
13	Link/Activity status indicators
14	Motor power (MP) connector

Item	Description
15	Motor brake (BC) connector
16	Ground terminal
17	Shunt resistor (RC) connector
18	AC mains input power (IPD) connector
19	DC bus (DC) connector (under cover) <sup>(2)</sup>
20	24V control input power (CP) connector
21	Safe Torque Off (STO) connector <sup>(3)</sup> (does not apply to 2198-Hxxx-ERS2 drives)

(1) Protective knock-out covers the 2198-H2DCK Hiperface-to-DSL feedback converter kit mounting hole. Remove knock-out for use with the converter kit.  
 (2) DC-bus connector ships with protective knock-out cover that can be removed for use in shared-bus configurations.  
 (3) Protective knock-out cover is removed on 2198-Hxxx-ERS (hardwired STO) drives.

# Technical Specifications - Kinetix 5500 Servo Drives

## Kinetix 5500 Input Power Specifications

Attribute	2198-H003-ERS 2198-H003-ERS2	2198-H008-ERS 2198-H008-ERS2	2198-H015-ERS 2198-H015-ERS2	2198-H025-ERS 2198-H025-ERS2	2198-H040-ERS 2198-H040-ERS2	2198-H070-ERS 2198-H070-ERS2
AC input voltage	195...264V rms, single-phase (240V nom) 195...264V rms, three-phase (240V nom) 324...528V rms, three-phase (480V nom)			195...264V rms, three-phase (240V nom) 324...528V rms, three-phase (480V nom)		
AC input frequency	47...63 Hz					
Main AC input current <sup>(1)</sup> 324...528V rms, three-phase 195...264V rms, single-phase	1.0 A 0.7 A	2.60 A 1.70 A	5.20 A 3.40 A	8.30 A N/A	13.4 A N/A	23.7 A N/A
Max inrush (0-pk)	15.0 A			30.0 A		60.0 A
Peak AC input current 324...528V rms, three-phase 195...264V rms, single-phase	3.0 A 2.1 A	7.8 A 5.1 A	15.6 A 10.2 A	24.9 A N/A	40.2 A N/A	71.1 A N/A
Line loss ride through	20 ms					
Control power DC input voltage	24V DC $\pm$ 10%					
Control power DC input current <sup>(1) (2)</sup> (non-brake motors)	0.4 A <sub>DC</sub>			0.8 A <sub>DC</sub>		1.3 A <sub>DC</sub>
Nominal bus output voltage	276...747V DC					
Continuous output current to bus 195...264V rms, single-phase 324...528V rms, three-phase	0.67 A <sub>DC</sub> 1.0 A <sub>DC</sub>	1.60 A <sub>DC</sub> 2.40 A <sub>DC</sub>	3.27 A <sub>DC</sub> 4.90 A <sub>DC</sub>	N/A 7.80 A <sub>DC</sub>	N/A 12.7 A <sub>DC</sub>	N/A 22.50 A <sub>DC</sub>
Peak output current to bus <sup>(3)</sup> 195...264V rms, single-phase 324...528V rms, three-phase	2.0 A <sub>DC</sub> 3.0 A <sub>DC</sub>	4.8 A <sub>DC</sub> 7.2 A <sub>DC</sub>	9.8 A <sub>DC</sub> 14.7 A <sub>DC</sub>	N/A 23.4 A <sub>DC</sub>	N/A 38.1 A <sub>DC</sub>	N/A 67.5 A <sub>DC</sub>
Continuous output power to bus Nom (230V rms, single-phase) Nom (230V rms, three-phase) Nom (480V rms, three-phase)	0.2 kW 0.3 kW 0.6 kW	0.5 kW 0.8 kW 1.6 kW	1.0 kW 1.6 kW 3.2 kW	N/A 2.5 kW 5.2 kW	N/A 4.0 kW 8.4 kW	N/A 7.2 kW 14.9 kW
Peak output power to bus Nom (230V rms, single-phase) Nom (230V rms, three-phase) Nom (480V rms, three-phase)	0.6 kW 1.0 kW 1.9 kW	1.6 kW 2.4 kW 4.9 kW	3.2 kW 4.9 kW 9.7 kW	N/A 7.8 kW 15.6 kW	N/A 12.7 kW 25.3 kW	N/A 22.4 kW 44.8 kW
DC input voltage (common bus follower)	276...747V DC					
DC input current (common bus follower)	1.0 A <sub>DC</sub>	2.4 A <sub>DC</sub>	4.9 A <sub>DC</sub>	7.8 A <sub>DC</sub>	12.7 A <sub>DC</sub>	22.5 A <sub>DC</sub>
Bus overvoltage	240V, nom AC input	440V DC				
	480V, nom AC input	810V DC				
Bus undervoltage	240V, nom AC input	138V DC				
	480V, nom AC input	275V DC				
Efficiency	97%					
Capacitive energy absorption	11.54 J		19.58 J	39.15 J	58.73 J	104.87 J
Short-circuit current rating	200,000 A (rms) symmetrical					

(1) All drives are limited to 1 power cycle per minute.

(2) For current values when motors include a holding brake and additional information, refer to [Control Power Current Specifications](#) on [page 73](#).

(3) Peak output current duration equals 1.0 second.

## Kinetix 5500 Output Power Specifications

Attribute	2198-H003-ERS 2198-H003-ERS2	2198-H008-ERS 2198-H008-ERS2	2198-H015-ERS 2198-H015-ERS2	2198-H025-ERS 2198-H025-ERS2	2198-H040-ERS 2198-H040-ERS2	2198-H070-ERS 2198-H070-ERS2
Bandwidth <sup>(1)</sup> Velocity loop, max Current loop	300 Hz 1000 Hz					
PWM frequency	8 kHz		4 kHz			
Continuous output current (rms)	1.0 A	2.5 A	5.0 A	8.0 A	13.0 A	23.0 A
Continuous output current (0-pk)	1.4 A	3.5 A	7.1 A	11.3 A	18.4 A	32.5 A
Peak output current (rms) <sup>(2)</sup>	2.5 A	6.25 A	12.5 A	20.0 A	32.5 A	57.5 A
Peak output current (0-pk) <sup>(2)</sup>	3.5 A	8.8 A	17.7 A	28.3 A	45.9A	81.3A
Continuous power out (nom) 195...264V rms, single-phase 195...264V rms, three-phase 324...528V rms, three-phase	0.2 kW 0.3 kW 0.6 kW	0.5 kW 0.8 kW 1.6 kW	1.0 kW 1.5 kW 3.2 kW	N/A 2.4 kW 5.1 kW	N/A 4.0 kW 8.3 kW	N/A 7.0 kW 14.6 kW
Internal shunt resistance	100 $\Omega$		60 $\Omega$			40 $\Omega$
Internal shunt power	30 W		50 W			75 W
Shunt on	775V plus 30V x bus regulator capacity/utilization <sup>(3)</sup>					
Shunt off	765V plus 30V x bus regulator capacity/utilization <sup>(3)</sup>					

(1) Bandwidth values vary based on tuning parameters and mechanical components.

(2) Peak current duration ( $T_{PKmax}$ ) equals 1.0 second.

(3) The shunt on and shunt off voltages increase during periods of shunting activity to promote sharing of shunt power in multi-axis configurations. Shunt utilization is equivalent to the BusRegulatorCapacity tag in the Logix Designer application.

## Control Power Current Specifications

Kinetix 5500 servo drives and the 2198 capacitor module have different 24V DC power consumption. Factors to consider when calculating the combined current demand from your 24V DC power supply include the following:

- Catalog number for each drive in the system
- Whether servo motors include the holding brake option
- Whether the system includes 2198 capacitor modules (1 to 4 modules are possible)

## Control Power Current Specifications

Drive Cat. No.	24V Current (non-brake motor) $A_{DC}$	24V Current (2 A brake motor) $A_{DC}$	24V Inrush Current <sup>(1)</sup> A
2198-H003-ERSx	0.4	2.4	2.0
2198-H008-ERSx			
2198-H015-ERSx	0.8	2.8	3.0
2198-H025-ERSx			
2198-H040-ERSx			
2198-H070-ERSx	1.3	3.3	
2198-CAPMOD-1300	0.3	N/A	2.0

(1) Inrush current duration is less than 30 ms.

## Peak Current Specifications

### Load Duty-cycle Profile Example

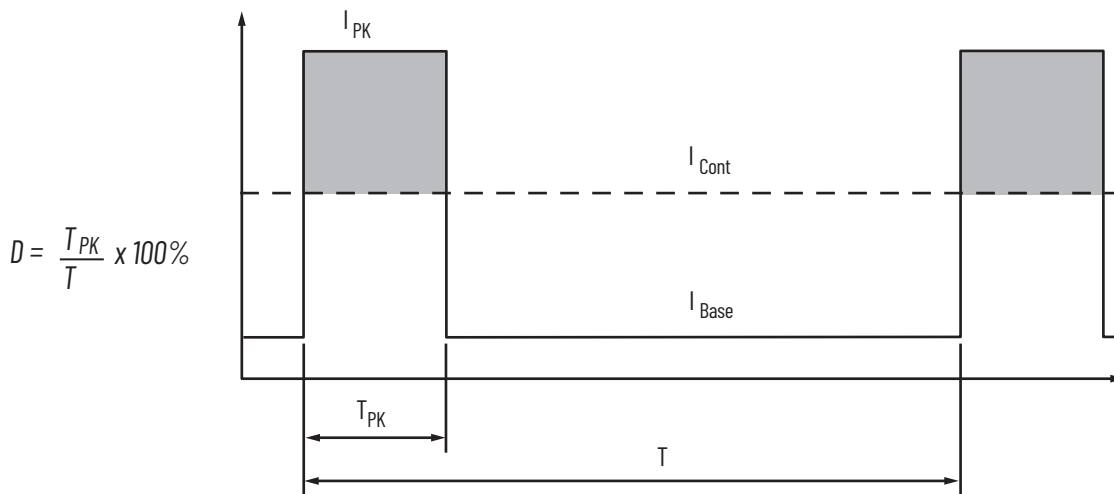

### Peak Duty Cycle Definition of Terms

Term	Definition (1)
Continuous Current Rating ( $I_{Cont}$ )	The maximum value of current that can be output continuously.
Peak Current Rating ( $I_{PKmax}$ )	The maximum value of peak current that the drive can output. This rating is valid only for overload times less than $T_{PKmax}$ .
Duty Cycle (D)	The ratio of time at peak to the Application Period is defined as: $D = \frac{T_{PK}}{T} \times 100\%$
Time at Peak ( $T_{PK}$ )	The time at peak current ( $I_{PK}$ ) for a given loading profile. Must be less than or equal to $T_{PKmax}$ .
Peak Current ( $I_{PK}$ )	The level of peak current for a given loading profile. $I_{PK}$ must be less than or equal to the Peak Current Rating ( $T_{PKMAX}$ ) of the drive.
Base Current ( $I_{Base}$ )	The level of current between the pulses of peak current for a given loading profile. $I_{Base}$ must be less than or equal to the continuous current rating ( $I_{Cont}$ ) of the drive.
Loading Profile	The loading profile is composed of $I_{PK}$ , $I_{Base}$ , $T_{PK}$ , and D (or T) values and completely specify the operation of the drive in an overload situation. These values are collectively defined as the Loading Profile of the drive.
Application Period (T)	The sum of the times at $I_{PK}$ ( $T_{PK}$ ) and $I_{Base}$ .

(1) All current values are specified as RMS.

**Peak Inverter Overload ( $T_{PK} < 1.0$  s)**

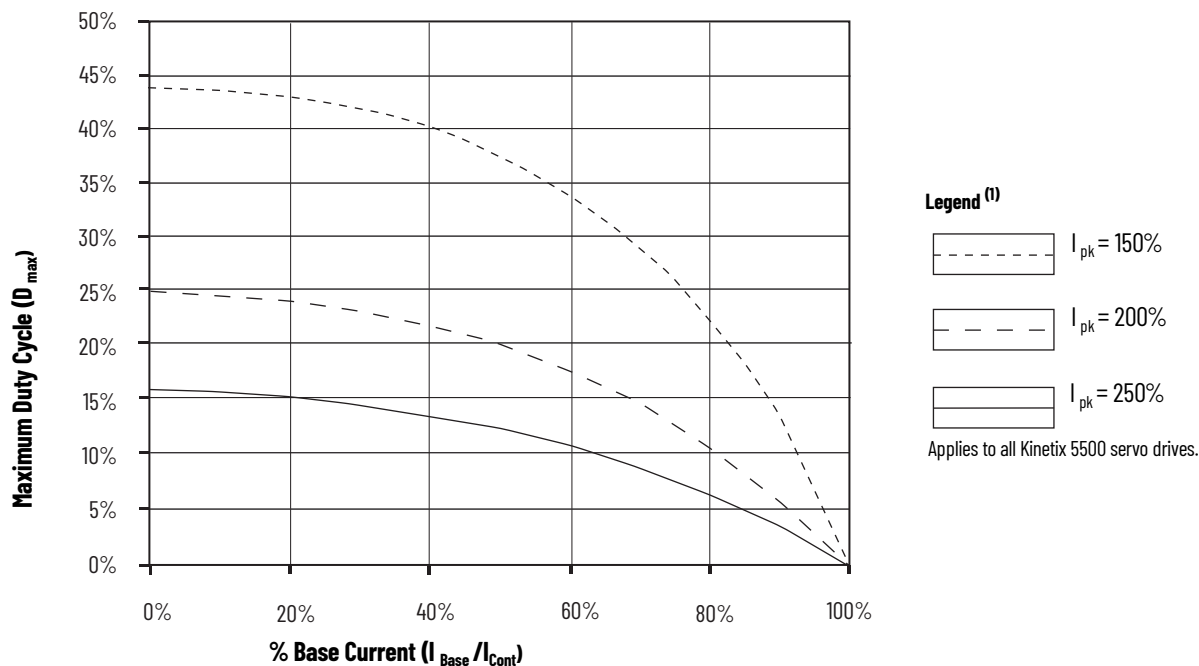

(1) Base current ( $I_{Base}$ ) and peak current ( $I_{pk}$ ) are a percentage of the continuous drive current rating ( $I_{Cont}$ ).

**Circuit Breaker/Fuse Specifications**

The Kinetix 5500 drives use internal solid-state motor short-circuit protection and, when protected by suitable branch circuit protection, are rated for use on a circuit capable of delivering up to 200,000 A (fuses) and 65,000 A (circuit breakers).

**Standalone Drive Systems**

Kinetix 5500 Drives			UL Applications		IEC (non-UL) Applications	
Drive Cat. No.	Drive Voltage, nom	Phase	Bussmann Fuses Cat. No.	Molded Case CB Cat. No.	DIN gG Fuses Amps (max)	Molded Case CB Cat. No.
2198-H003-ERSx	240V	Single-phase	KTK-R-2	140U-D6D2-B10 140UT-D7D2-B10	2	140U-D6D2-B10 140UT-D7D2-B10
	240/480V	Three-phase	KTK-R-3	140U-D6D3-B20 140UT-D7D3-B20	4	140U-D6D3-B20 140UT-D7D3-B20
2198-H008-ERSx	240V	Single-phase	KTK-R-5	140U-D6D2-B20 140UT-D7D2-B20	6	140U-D6D2-B20 140UT-D7D2-B20
	240/480V	Three-phase	KTK-R-7	140U-D6D3-B60 140UT-D7D3-B60	6	140U-D6D3-B60 140UT-D7D3-B60
2198-H015-ERSx	240V	Single-phase	KTK-R-10	140U-D6D2-B80 140UT-D7D3-B80	10	140U-D6D2-B80 140UT-D7D3-B80
	240/480V	Three-phase	KTK-R-15	140U-D6D3-C12 140UT-D7D3-C12	16	140U-D6D3-C12 140UT-D7D3-C12
2198-H025-ERSx	240/480V	Three-phase	KTK-R-20	140U-D6D3-C20 140UT-D7D3-C20	20	140U-D6D3-C20 140UT-D7D3-C20
2198-H040-ERSx	240/480V	Three-phase	KTK-R-25	140U-D6D3-C25 140UT-D7D3-C25	25	140U-D6D3-C25 140UT-D7D3-C25
2198-H070-ERSx	240/480V	Three-phase	LPJ-35SP	140G-G6C3-C40	35	140G-G6C3-C40

**Shared DC (common-bus) Drive Systems**

Kinetix 5500 Drives Cat. No.	Drive Voltage, (three-phase) nom	UL Applications		IEC (non-UL) Applications	
		Bussmann Fuses Cat. No.	Molded Case CB Cat. No.	DIN gG Fuses Amps (max)	Molded Case CB Cat. No.
2198-H003-ERSx	240/480V	KTK-R-10	140U-D6D3-C15 140UT-D7D2-C15	10	140U-D6D3-C15 140UT-D7D2-C15
2198-H008-ERSx	240/480V	KTK-R-10	140U-D6D3-C15 140UT-D7D3-C15	10	140U-D6D3-C15 140UT-D7D3-C15
2198-H015-ERSx	240/480V	KTK-R-15	140U-D6D3-C15 140UT-D7D3-C15	16	140U-D6D3-C15 140UT-D7D3-C15
2198-H025-ERSx	240/480V	KTK-R-20	140U-D6D3-C20 140UT-D7D3-C20	20	140U-D6D3-C20 140UT-D7D3-C20
2198-H040-ERSx	240/480V	KTK-R-25	140U-D6D3-C25 140UT-D7D3-C25	25	140U-D6D3-C25 140UT-D7D3-C25
2198-H070-ERSx	240/480V	LPJ-35SP	140G-G6C3-C40	35	140G-G6C3-C40

**Shared AC Drive Systems**

**Input Power UL Circuit-protection Specifications**

Kinetix 5500 Drives Cat. No.	Drive Voltage, (three-phase) nom	Bussmann Fuses Cat. No.				Molded Case CB Cat. No.			
		2 Axes	3 Axes	4 Axes	5 Axes	2 Axes	3 Axes	4 Axes	5 Axes
2198-H003-ERSx	240/480V	KTK-R-15				140U-D6D3-C15 140UT-D7D3-C15			
2198-H008-ERSx	240/480V	KTK-R-15				140U-D6D3-C15 140UT-D7D3-C15			
2198-H015-ERSx	240/480V	KTK-R-20	KTK-R-25	N/A		140U-D6D3-C15 140UT-D7D3-C15	140U-D6D3-C20 140UT-D7D3-C20	N/A	
2198-H025-ERSx	240/480V	KTK-R-30		N/A		140U-D6D3-C25 140UT-D7D3-C25	140U-D6D3-C30 140UT-D7D3-C30	N/A	
2198-H040-ERSx	240/480V	LPJ-35SP	LPJ-45SP	N/A		140G-G6C3-C40	140G-G6C3-C50	N/A	
2198-H070-ERSx	240/480V	LPJ-60SP	N/A			140G-G6C3-C60	N/A		

**Input Power IEC (non-UL) Circuit-protection Specifications**

Kinetix 5500 Drives Cat. No.	Drive Voltage, (three-phase) nom	DIN gG Fuses Amps (max)				Molded Case CB Cat. No.			
		2 Axes	3 Axes	4 Axes	5 Axes	2 Axes	3 Axes	4 Axes	5 Axes
2198-H003-ERSx	240/480V	16				140U-D6D3-C15 140UT-D7D3-C15			
2198-H008-ERSx	240/480V	16				140U-D6D3-C15 140UT-D7D3-C15			
2198-H015-ERSx	240/480V	20	25	N/A		140U-D6D3-C15 140UT-D7D3-C15	140U-D6D3-C20 140UT-D7D3-C20	N/A	
2198-H025-ERSx	240/480V	32		N/A		140U-D6D3-C25 140UT-D7D3-C25	140U-D6D3-C30 140UT-D7D3-C30	N/A	
2198-H040-ERSx	240/480V	35	50	N/A		140G-G6C3-C40	140G-G6C3-C50	N/A	
2198-H070-ERSx	240/480V	63	N/A			140G-G6C3-C60	N/A		



## Shared AC/DC and Hybrid Systems

### Input Power UL Circuit-protection Specifications

Kinetix 5500 Drives Cat. No.	Drive Voltage, (three-phase) nom	Bussmann Fuse Cat. No.							Molded Case CB Cat. No.							
		2 Axes	3 Axes	4 Axes	5 Axes	6 Axes	7 Axes	8 Axes	2 Axes	3 Axes	4 Axes	5 Axes	6 Axes	7 Axes	8 Axes	
2198-H003-ERSx	240/480V	KTK-R-10					KTK-R-15		140U-D6D3-C15 140UT-D7D3-C15							
2198-H008-ERSx	240/480V	KTK-R-15				KTK-R-20			140U-D6D3-C15 140UT-D7D3-C15					140U-D6D3-C20 140UT-D7D3-C20		
2198-H015-ERSx	240/480V	KTK-R-20			N/A				140U-D6D3-C15 140UT-D7D3-C15		140U-D6D3-C20 140UT-D7D3-C20		N/A			
2198-H025-ERSx	240/480V	KTK-R-30			N/A				140U-D6D3-C20 140UT-D7D3-C20		140U-D6D3-C30 140UT-D7D3-C30		N/A			
2198-H040-ERSx	240/480V	KTK-R-30	LPJ-45SP	LPJ-50SP	N/A				140U-D6D3-C30 140UT-D7D3-C30		140G-G6C3-C50		N/A			
2198-H070-ERSx	240/480V	LPJ-50SP	N/A					140G-G6C3-C50		N/A						

### Input Power IEC (non-UL) Circuit-protection Specifications

Kinetix 5500 Drives Cat. No.	Drive Voltage, (three-phase) nom	DIN gG Fuses Amps (max)							Molded Case CB Cat. No.							
		2 Axes	3 Axes	4 Axes	5 Axes	6 Axes	7 Axes	8 Axes	2 Axes	3 Axes	4 Axes	5 Axes	6 Axes	7 Axes	8 Axes	
2198-H003-ERSx	240/480V	10					16		140U-D6D3-C15 140UT-D7D3-C15							
2198-H008-ERSx	240/480V	16				20			140U-D6D3-C15 140UT-D7D3-C15					140U-D6D3-C20 140UT-D7D3-C20		
2198-H015-ERSx	240/480V	20			N/A				140U-D6D3-C15 140UT-D7D3-C15		140U-D6D3-C20 140UT-D7D3-C20		N/A			
2198-H025-ERSx	240/480V	32			N/A				140U-D6D3-C20 140UT-D7D3-C20		140U-D6D3-C30 140UT-D7D3-C30		N/A			
2198-H040-ERSx	240/480V	32	50		N/A				140U-D6D3-C30 140UT-D7D3-C30		140G-G6C3-C50		N/A			
2198-H070-ERSx	240/480V	50	N/A					140G-G6C3-C50		N/A						

## Power Dissipation Specifications

Use this table to size an enclosure and calculate required ventilation for your Kinetix 5500 drive system.

Kinetix 5500 Drive Cat. No.	Usage as % of Rated Power Output (watts)				
	20%	40%	60%	80%	100%
2198-H003-ERSx 2198-H008-ERSx	12	25	37	50	62
2198-H015-ERSx 2198-H025-ERSx 2198-H040-ERSx	40	80	120	160	200
2198-H070-ERSx	64	128	192	256	320

## Weight Specifications

Kinetix 5500 Drive Cat. No.	Weight, approx kg (lb)
2198-H003-ERSx 2198-H008-ERSx	1.4 (3.0)
2198-H015-ERSx 2198-H025-ERSx 2198-H040-ERSx	2.3 (5.0)
2198-H070-ERSx	4.1 (9.0)

## Maximum Cable Lengths

The Kinetix 5500 drive maximum cable length depends on several factors, including the drive/motor combination and motor/cable combination (see [Drive/Motor/Cable Considerations](#) table below). The maximum cable length also depends on the AC input-power source used in the application, as shown on [page 79](#). Use the shorter cable length specified between the two tables for your application.

### Drive/Motor/Cable Considerations

Kinetix 5500 Servo Drive Cat. No.	Kinetix VP Servo Motors/Actuators m (ft)		Other Compatible Rotary Motors and Linear Actuators <sup>(1)</sup>
	Standard (non-flex) Cables Cat. No. 2090-CSxM1DF-xxAAxx Cat. No. 2090-CSxM1DG-xxxAxx Cat. No. 2090-CSxM1E1-xxVAxx	Continuous-flex Cables <sup>(2)</sup> Cat. No. 2090-CSxM1DF-xxAFxx Cat. No. 2090-CSxM1DG-xxxFxx Cat. No. 2090-CSxM1E1-xxxFxx	Kinetix 2090 Motor/Actuator Cables <sup>(3)</sup> Cat. No. 2090-CxxM7DF m (ft)
2198-H003-ERSx 2198-H008-ERSx	50 (164)	30 (98.4)	20 (65.6)
2198-H015-ERSx 2198-H025-ERSx 2198-H040-ERSx	50 (164)		
2198-H070-ERSx	50 (164)		

(1) Requires use of the 2198-H2DCK Hiperface-to-DSL feedback converter kit (series B or later).

(2) When using any continuous-flex cable (whether extension or flying-lead) in your application, the maximum cable length including any standard (non-flex) cable back to the drive, is 30 m (98.4 ft).

(3) The 20 m (65.6 ft) limitation is attributed to the 2090-CPxM7DF power/brake cable. In 2198-H2DCK converter kit applications, you can replace the 2090-CPxM7DF power/brake cable with a 2090-CSxM1DF or 2090-CSxM1DG single motor cable (and reuse the 2090-CFBM7DF feedback cable) to increase the maximum cable length to 50 m (164 ft). This applies to only 18 and 14 AWG single cables. 2090-CSBM1Dx-10xxxx (10 AWG/M40 connector) single cables are not compatible with 2090-CPBM7DF-10Axxx (10 AWG/M40 connector) power/brake cables.

Refer to the Kinetix Rotary and Linear Motion Cable Specifications Technical Data, publication [KNX-TD004](#), for cable specifications.

Maximum cable length for the following input power configurations are dependent on these configuration variables:

- AC input power type
  - WYE grounded
  - WYE impedance grounded
  - WYE/Delta corner grounded or ungrounded
- AC input voltage
  - 240V AC
  - 400V AC
  - 480V AC

**AC Input Power Considerations (400V-class motors and actuators)**

AC Input Power Source Type	Compatible Motor and Actuator Cat. No.	Cable Length, max m (ft)	
		400V AC Input	480V AC Input
<ul style="list-style-type: none"> <li>• WYE Grounded</li> <li>• WYE Impedance Grounded <sup>(1)</sup></li> <li>• WYE Ungrounded <sup>(2)</sup></li> <li>• Delta Ungrounded <sup>(2)</sup></li> </ul>	LDAT-Sxxxxxx-xDx	10 (32.8)	
	<ul style="list-style-type: none"> <li>• VPx-B063xx, VPx-B075xx</li> <li>• VPx-B100xx...VPx-B165xx</li> <li>• VPAR-B1xxxx, VPAR-B2xxxx</li> <li>• MPAR-B3xxxx</li> <li>• VPAR-B3xxxx</li> <li>• MPx-B3xxx...MPx-B6xxx</li> <li>• MPM-B115xx...MPM-B215xx</li> </ul>	50 (164)	
	<ul style="list-style-type: none"> <li>• MPL-B15xx, MPL-B2xx</li> <li>• MPAR-B1xxxx, MPAR-B2xxxx</li> <li>• MPAS-Bxxxx1, MPAS-Bxxxx2</li> <li>• MPAI-Bxxxx</li> </ul>	50 (164)	20 (65.6)
Delta Corner Grounded	<ul style="list-style-type: none"> <li>• VPx-B063xx, VPx-B075xx</li> <li>• MPL-B15xx, MPL-B2xx</li> <li>• MPAR-B1xxxx, MPAR-B2xxxx</li> <li>• VPAR-B1xxxx, VPAR-B2xxxx</li> <li>• MPAS-Bxxxx1, MPAS-Bxxxx2</li> <li>• MPAI-Bxxxx</li> </ul>	50 (164)	15 (49.2)
	<ul style="list-style-type: none"> <li>• VPx-B100xx...VPx-B165xx</li> <li>• MPAR-B3xxxx</li> <li>• VPAR-B3xxxx</li> <li>• MPx-B3xxx...MPx-B6xxx</li> <li>• MPM-B115xx...MPM-B215xx</li> </ul>	50 (164)	

(1) Impedance grounded systems running in ground fault conditions, for prolonged periods of time, cause additional stress to the motor insulation and can cause premature motor failure.  
 (2) Unbalanced, floating, ungrounded systems can cause additional stress to the motor.

**AC Input Power Considerations (200V-class motors and actuators)**

AC Input Power Source Type	Compatible Motor and Actuator Cat. No.	Cable Length, max m (ft)
		240V AC Input
Delta Corner Grounded	<ul style="list-style-type: none"> <li>• VPx-A063xx, VPx-A075xx</li> <li>• VPx-A100xx...VPx-A165xx</li> <li>• MPL-A15xx, MPL-A2xx</li> <li>• MPx-A3xxx...MPx-A5xxx</li> <li>• MPM-A115xx...MPM-A215xx</li> <li>• MPAR-A1xxxx, MPAR-A2xxxx, MPAR-A3xxxx</li> <li>• VPAR-A1xxxx, VPAR-A2xxxx, VPAR-A3xxxx</li> <li>• MPAS-Axxxx1, MPAS-Axxxx2</li> <li>• MPAI-Axxxx</li> </ul>	50 (164)

Combined power cable lengths for all axes on the same DC bus must not exceed 250 m (820 ft).

**IMPORTANT** System performance was tested at these cable lengths. These limitations also apply when meeting CE requirements.

## Dimensions - Kinetix 5500 Servo Drives

These drawings provide mounting dimensions for Kinetix 5500 servo drives. Also included are drawings showing the impact of compatible motor feedback connector kits on the mounting dimensions. Kinetix 5500 servo drives include the 2198-KITCON-DSL feedback connector kit for use with Kinetix VP motors. The 2198-H2DCK feedback converter kit, for Hiperface-to-DSL conversion, is used with Kinetix LDAT linear thrusters and Kinetix MP rotary motors and linear actuators. Refer to [page 81](#) for dimensions when using the converter kit.

### Kinetix 5500 Drives with 2198-KITCON-DSL Connector Kit

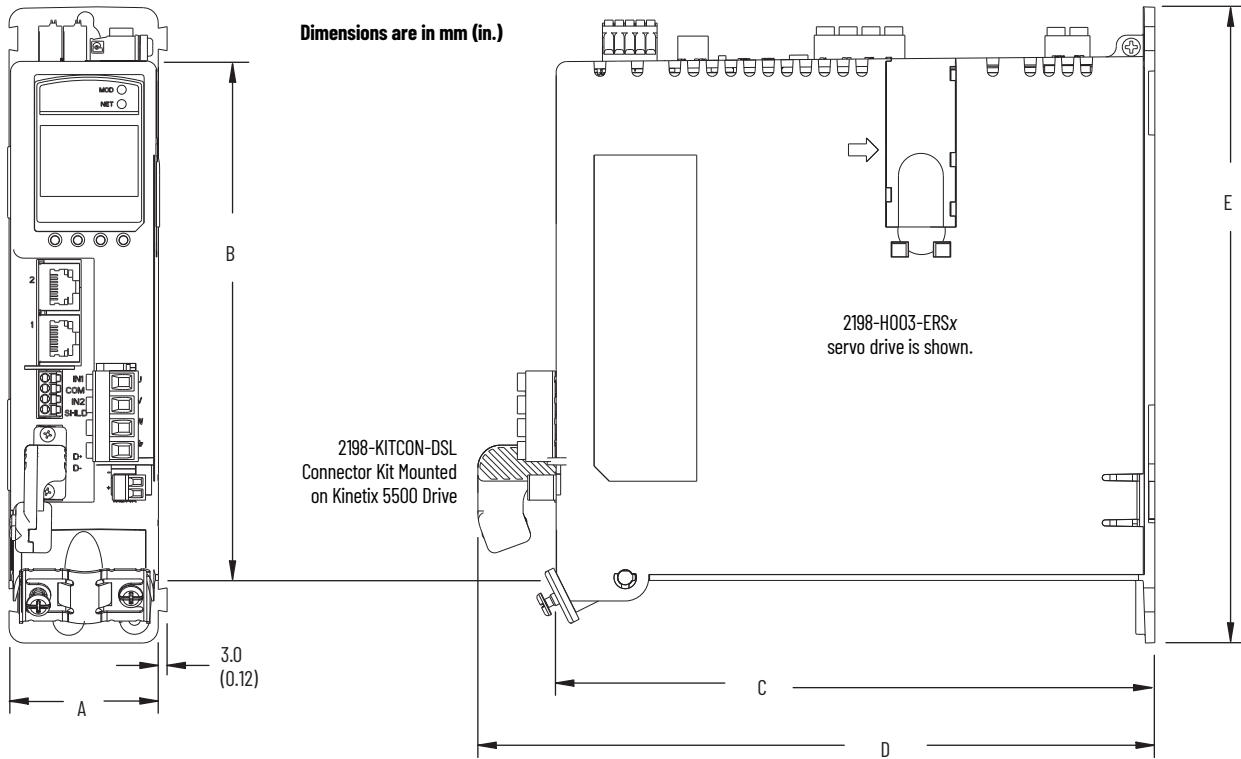

Kinetix 5500 Drive Cat. No.	Frame Size	A mm (in.)	B mm (in.)	C mm (in.)	D mm (in.)	E mm (in.)
2198-H003-ERSx	Frame 1	50 (1.97)	175 (6.89)	200 (7.87)	226 (8.90)	215 (8.46)
2198-H008-ERSx						265 (10.43)
2198-H015-ERSx	Frame 2	55 (2.16)	225 (8.86)			200 (7.87)
2198-H025-ERSx				294 (11.57)		
2198-H040-ERSx	Frame 3	85.2 (3.35)	250 (9.84)	200 (7.87)	226 (8.90)	
2198-H070-ERSx						294 (11.57)

Kinetix 5500 Drives with 2198-H2DCK Converter Kit

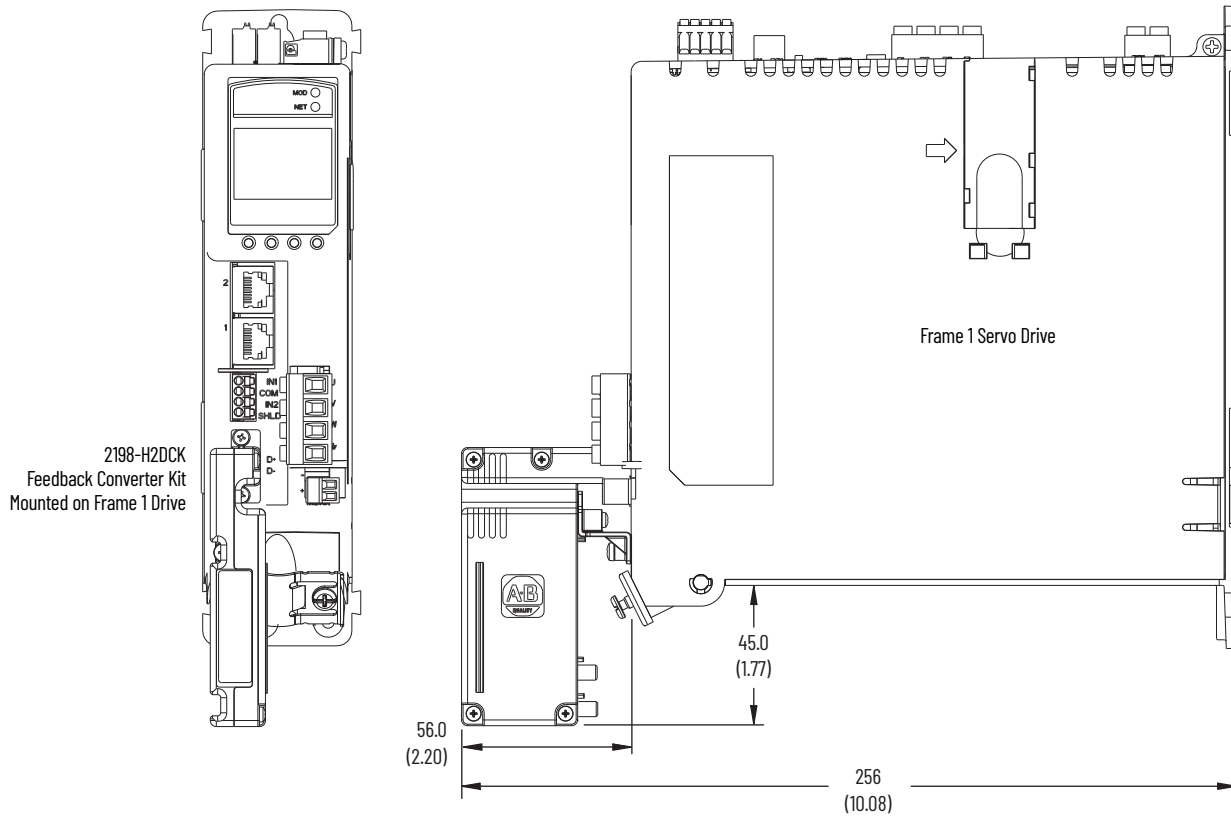

Dimensions are in mm (in.)

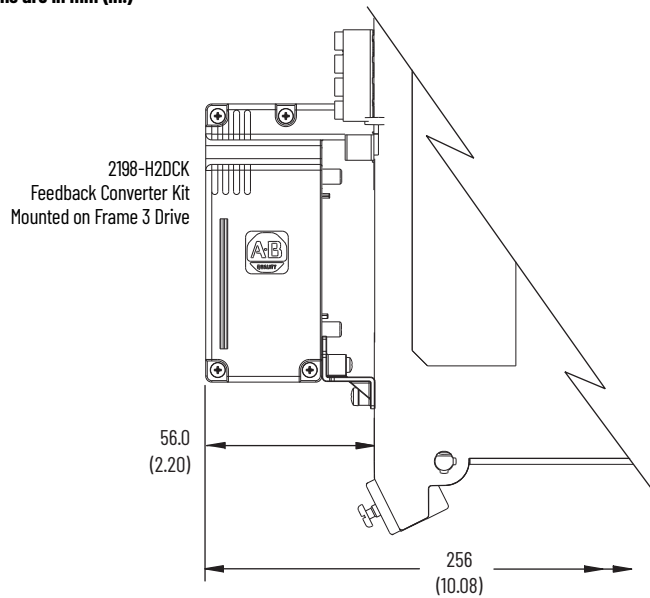
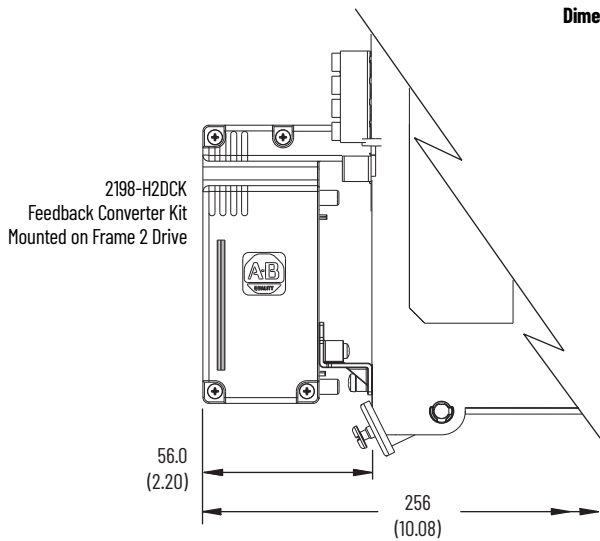

Refer to [Hiperface-to-DSL Feedback Converter Kit](#) on [page 89](#) for motor/actuator compatibility and product dimensions.

## Environmental Specifications - Kinetix 5500 Servo Drives

Attribute	Operational Range	Storage Range (nonoperating)
Ambient temperature (with 2198-KITCON-DSL connector kit)	0...50 °C (32...122 °F)	-40...+70 °C (-40...+158 °F)
Ambient temperature (with 2198-H2DCK converter kit and the existing 2090-CPBM7DF motor power/brake cable and 2090-CFBM7DF motor feedback cable) <sup>(1)</sup>	0...40 °C (32...104 °F)	
Relative humidity	5...95% noncondensing	5...95% noncondensing
Protection class (IEC 60529)	IP20	
Degree of pollution (IEC 61800-5-1)	2	
Altitude	<ul style="list-style-type: none"> <li>1000 m (3281 ft) derate 15% per 1000 m above 1000 m</li> <li>2000 m (6562 ft) max, with corner-grounded input power</li> <li>3000 m (9843 ft) max, with non corner-grounded input power</li> </ul>	3000 m (9843 ft) during transport
Vibration	5...55 Hz @ 0.35 mm (0.014 in.) double amplitude, continuous displacement; 55...500 Hz @ 2.0 g peak constant acceleration	
Shock	15 g, 11 ms half-sine pulse (3 pulses in each direction of 3 mutually perpendicular directions)	

(1) When the 2198-H2DCK converter kit is used with the existing motor feedback cable (catalog number 2090-CFBM7DF) and single motor cable (catalog number 2090-CSBM1DF) for power and brake connections, derating the operational ambient temperature is not required.

## Certifications - Kinetix 5500 Servo Drives

Agency Certification <sup>(1)</sup>	Standards
cULus <sup>(2)</sup>	UL Listed to U.S. and Canadian safety standards (UL 508C File E59272). Solid-state motor overload protection provides dynamic fold-back of motor current when 110% of the motor rating is reached with a peak current limit based on the peak rating of the motor as investigated by UL to comply with UL 508C (UL File E59272).
CE	European Union 2004/108/EC EMC Directive compliant with IEC 61800-3:2004 + A1:2012: Adjustable Speed Electrical Power Drive Systems - Part 3; EMC Product Standard including specific test methods. European Union 2006/95/EC Low Voltage Directive compliant with IEC 61800-5-1:2007 - Adjustable speed electrical power drive systems.
Functional Safety	TÜV certified for functional safety when used as described in the Kinetix 5500 Servo Drives User Manual, publication <a href="#">2198-UM001</a> . <ul style="list-style-type: none"> <li>2198-Hxxx-ERS (hardwired safety) drive ratings: up to Performance Level (PL) d, Category 3 according to ISO 13849; up to SIL CL2 according to IEC 61508, IEC 61800-5-2, and IEC 62061.</li> <li>2198-Hxxx-ERS2 (integrated safety) drive ratings: up to Performance Level (PL) e, Category 3 according to ISO 13849; up to SIL CL3 according to IEC 61508, IEC 61800-5-2, and IEC 62061.</li> </ul>
RCM	Australian Radiocommunications Act, compliant with: <ul style="list-style-type: none"> <li>Radiocommunications Act: 1992 (including Amendments up to 2017)</li> <li>Radiocommunications (Electromagnetic Compatibility) Standard: 2017</li> <li>Radiocommunications Labeling ((Compliance Labelling - Incidental Emissions) Notice: 2017</li> <li>AS/NZS CISPR 11: 2002 (Group 1, Class A)</li> </ul>
KC	Korean Registration of Broadcasting and Communications Equipment, compliant with: <ul style="list-style-type: none"> <li>Article 58-2 of Radio Waves Act, Clause 3</li> <li>Registration number: KCC-REM-RAA-2198</li> </ul>
ODVA	EtherNet/IP conformance tested.
OSHA	Maximum audible noise from the servo drive system complies with OSHA standard 3074, Hearing Conservation (<85 dBA).
Ecodesign	IE2 efficiency class per Ecodesign regulation EU 2019/1781

(1) See [rok.auto/certifications](#) for declarations of conformity, certificates, and other certification details.

(2) UL has not evaluated the Safe Torque Off or the Safe Speed Monitor options in these products.

## Accessories - Kinetix 5500 Servo Drives

Kinetix 5500 drive accessories include the 2198 capacitor module, shunt resistors, the encoder output module, AC line filters, and the shared-bus connection system. Kinetix 5500 servo drives are also compatible with 2097 external shunt resistors.

### Capacitor Module

The Kinetix 5500 capacitor module provides 1360  $\mu\text{F}$  capacitance for applications where the Kinetix 5500 internal shunt module capacity is exceeded. The capacitor module can be used alone or in combination with a 2097 external shunt module for applications with excessive regenerative energy.

The 2198-CAPMOD-1300 capacitor module is an option for Kinetix 2198 servo drive configurations with 200V or 400V-class operation. This section contains features, specifications, and product dimensions.

**IMPORTANT** Use the 2198-CAPMOD-1300 capacitor module in Kinetix 5500 drive configurations where DC-bus power is shared through the shared-bus connection system. You cannot use the capacitor module in configurations where only AC input power is shared.

#### Capacitor Module Features and Indicators

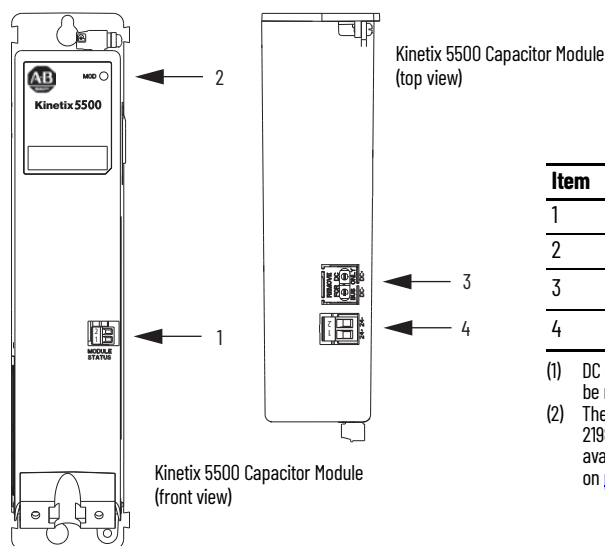

Item	Description
1	Module status (MS) connector
2	Module status indicator
3	DC bus (DC) connector (under cover) <sup>(1) (2)</sup>
4	24V control input power (CP) connector <sup>(2)</sup>

- (1) DC bus connector ships with protective knock-out cover that can be removed for use in shared-bus configurations.
- (2) The shared-bus kit for the capacitor module, catalog number 2198-KITCON-CAP1300, is included. Replacement kits are also available, refer to [Power-sharing Bus-bars and Connector Sets](#) on [page 90](#).

#### Capacitor Module Support

Kinetix 5500 Drive Cat. No.	Frame Size	Standalone Single Phase Operation	Three-phase Operation			
			Standalone	Shared DC	Shared AC/DC	Shared AC/DC Hybrid
<b>Number of capacitor modules connected, max</b>						
2198-H003-ERSx <sup>(1)</sup>	1	0	0		2	
2198-H008-ERSx <sup>(1)</sup>			1			
2198-H015-ERSx <sup>(1)</sup>			2	N/A	3	
2198-H025-ERSx	3	4				
2198-H040-ERSx						
2198-H070-ERSx	3		4			

(1) Catalog number 2198-H003-ERS and any drive in standalone single-phase operation is not compatible with the Kinetix 5500 capacitor module.

Capacitor Module Dimensions

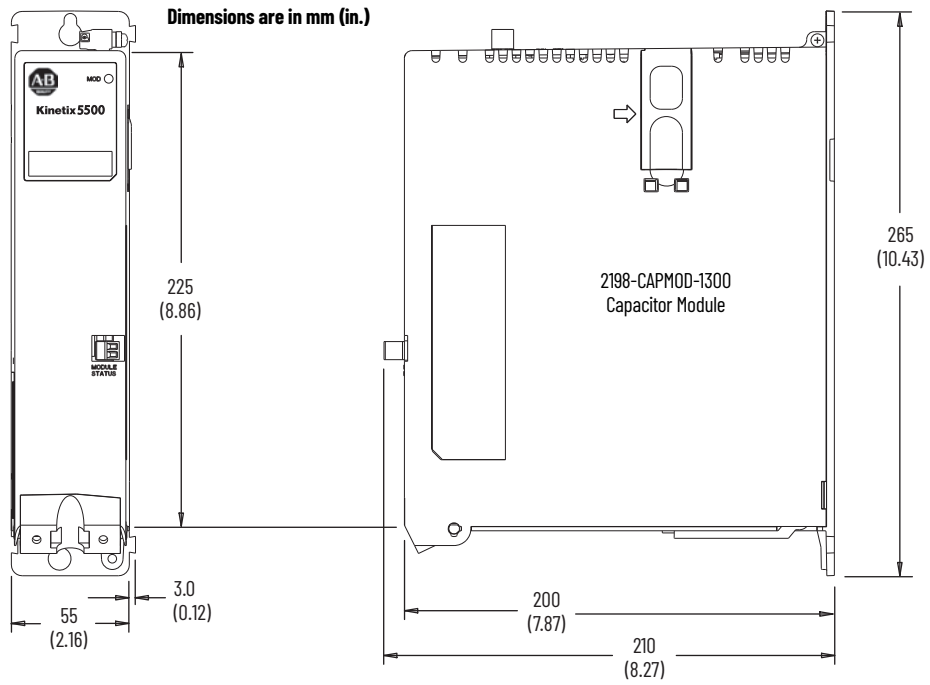

Capacitor Module Specifications

Capacitor Module Cat. No.	Voltage Range V DC	Capacitance $\mu\text{F}$	Energy Storage J	Continuous Current A, 0-pk	Weight kg (lb)
2198-CAPMOD-1300	275...747	1360	446 (460V AC input) 132 (230V AC input)	26.0	2.3 (5.0)



## Shunt Resistor

The 2097 passive shunts are compatible with Kinetix 5500 servo drives. The shunt resistor wires directly to the drive.

Refer to [Passive Shunt Modules and Resistors Dimensions on page 135](#) for product dimensions and additional specifications.

## Encoder Output Module

The Allen-Bradley encoder output module (catalog number 2198-ABQE) is a DIN-rail mounted EtherNet/IP network-based standalone module capable of outputting encoder pulses to a customer-supplied peripheral device (cameras, for example, used in line-scan vision systems). The encoder output module supports real and virtual axes for systems using the integrated motion on EtherNet/IP network. For more information, refer to [Encoder Output Module on page 137](#).

## AC Line Filters

The Kinetix 5500 drives were tested by using these recommended line filters and are required to meet CE requirements. These 2198 AC line filters apply to Kinetix 5500 drives used in single-phase and three-phase operation.

See [AC Line Filter Dimensions and Specifications on page 138](#) for product dimensions and additional specifications.

### Single Drive AC Line Filter Selection

Kinetix Drive Module Cat. No.	AC Line Filter Cat. No.
2198-H003-ERSx 2198-H008-ERSx 2198-H015-ERSx	2198-DB08-F
2198-H025-ERSx 2198-H040-ERSx	<ul style="list-style-type: none"> <li>• 2198-DBR20-F or</li> <li>• 2198-DB20-F</li> </ul>
2198-H070-ERSx	<ul style="list-style-type: none"> <li>• 2198-DBR40-F or</li> <li>• 2198-DB42-F</li> </ul>

### Multi-axis AC Line Filter Selection for Shared AC and Shared AC/DC and Hybrid Systems

Kinetix 5500 Drives Cat. No.	Drive Voltage, (three-phase) nom	AC Line Filter Cat. No.						
		2 Axes	3 Axes	4 Axes	5 Axes	6 Axes	7 Axes	8 Axes
2198-H003-ERSx	240/480V	2198-DBR20-F						
2198-H008-ERSx	240/480V	2198-DBR20-F						
2198-H015-ERSx	240/480V	2198-DBR20-F				-		
2198-H025-ERSx	240/480V	2198-DBR40-F				-		
2198-H040-ERSx	240/480V	2198-DBR40-F		2198-DBR90-F		-		
2198-H070-ERSx	240/480V	2198-DBR90-F		-				

### 2198-DBRxx-F AC Line Filter Specifications

AC Line Filter Cat. No.	Voltage Rating, max	Current Rating A @ 50 °C (122 °F)	Power Loss W	Leakage Current mA	Weight, approx kg (lb)	Operating Temperature
2198-DBR20-F	528V AC three-phase 50/60 Hz	20	4.2	30.0	1.0 (2.20)	0...50 °C (32...122 °F)
2198-DBR40-F		54	15.0		3.3 (7.28)	
2198-DBR90-F		90	16.8		34.0	

### 2198-DBxx-F AC Line Filter Specifications

AC Line Filter Cat. No.	Voltage Rating, max	Current Rating A @ 50 °C (122 °F)	Power Loss W	Leakage Current mA	Weight, approx kg (lb)	Operating Temperature
2198-DB08-F <sup>(1)</sup>	528V AC three-phase 50/60 Hz	7.5	3.6	2.5	0.77 (1.70)	0...50 °C (32...122 °F)
2198-DB20-F		20	5.1	5.2	1.63 (3.59)	
2198-DB42-F		42	14.7	4.0	2.70 (5.95)	

(1) Applies to installations with single-phase or three-phase input power.

## Shared-bus Connection System

The shared-bus connection system is used to extend the mains AC input, 24V control input, and the DC-bus power from drive-to-drive in shared-bus multi-axis configurations.

**IMPORTANT** When the shared-bus connection system is used, the zero-stack tab and cutout must be engaged between adjacent drives.

The shared-bus connection system is composed of three components:

- Input wiring connectors that plug into the leftmost drive and receive input wiring for mains AC and 24V DC.
- AC bus, DC bus, and 24V DC T-connectors that plug into the drives downstream from the first where AC, DC, and/or 24V control power is shared. DC bus T-connectors also plug into the first drive where DC-bus power is shared.
- Bus bars that connect between drives to extend the mains AC bus, DC bus, and 24V DC control power from drive-to-drive.

### Shared-bus Connection System Example

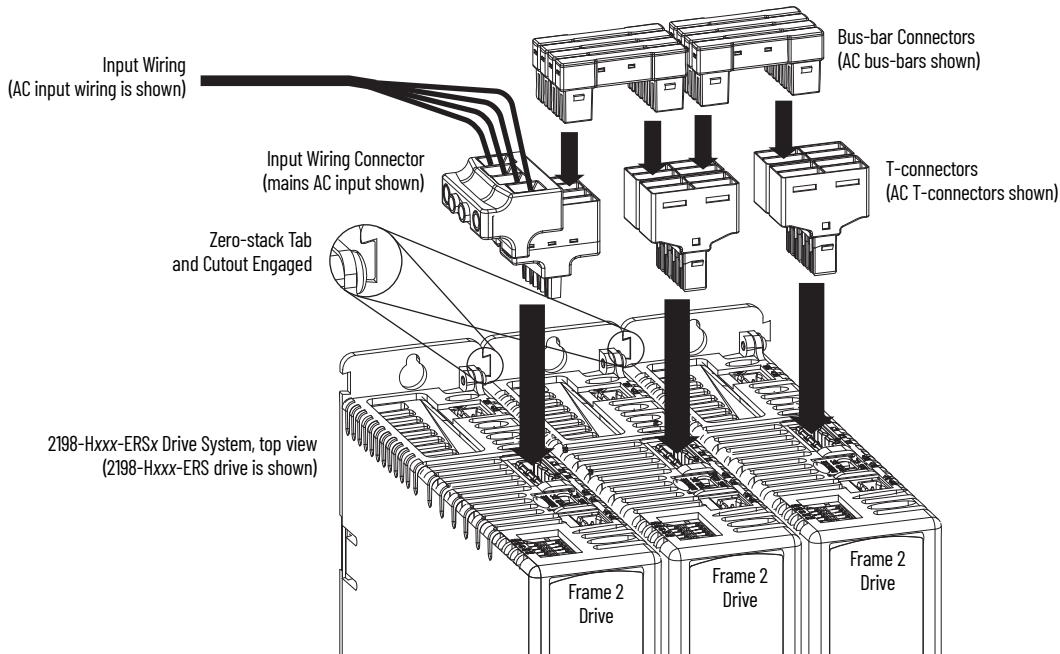

For each shared-bus servo drive system, you'll need one connector kit catalog number for each drive. Use these tables to determine which connector kits you'll need for your system.

**Input Power Connector Kit Catalog Numbers**

Frame Size	Kit Cat. No.	Description	Contents	Illustration
1 and 2	2198-H040-ADP-IN	Kinetix 5500 Frame 1 and 2 connectors for the first drive in a multi-axis system.	<ul style="list-style-type: none"> <li>AC input connector for frame 1 and 2 drives</li> <li>DC bus T-connector</li> <li>Control power input connector</li> </ul>	<p>AC Input Connector DC Bus T-connector Control Power Input Connector</p>
3	2198-H070-ADP-IN	Kinetix 5500 Frame 3 connectors for the first drive in a multi-axis system.	<ul style="list-style-type: none"> <li>AC input connector for frame 3 drive</li> <li>DC bus T-connector</li> <li>Control power input connector</li> </ul>	

Use these connector kits when the first drive is frame 1, 2, or 3 and the follower drive is frame 1 or 2.

**Frame 1 or 2 Follower Drive Connector Kit Catalog Numbers**

Kit Cat. No.	Description	Contents	Illustration
2198-H040-A-T	T-connector and bus-bars for the AC bus on Frame 1 or 2 follower drives	<ul style="list-style-type: none"> <li>AC bus T-connector</li> <li>Bus-bar connectors, 55 mm, quantity 4</li> </ul>	<p>Bus-bar Connectors (4x) AC Bus T-connector</p>
2198-H040-D-T	T-connector and bus-bars for the DC bus on Frame 1 or 2 follower drives	<ul style="list-style-type: none"> <li>DC bus T-connector</li> <li>Bus-bar connectors, 55 mm, quantity 2</li> </ul>	<p>Bus-bar Connectors (2x) T-connector</p>
2198-H040-P-T	T-connector and bus-bars for control power on Frame 1 or 2 follower drives	<ul style="list-style-type: none"> <li>Control power T-connector</li> <li>Bus-bar connectors, 55 mm, quantity 2</li> </ul>	<p>Control Power T-connector Bus-bar Connectors (2x)</p>
2198-H040-AD-T	T-connectors and bus-bars for the AC and DC bus on Frame 1 or 2 follower drives	<ul style="list-style-type: none"> <li>AC bus T-connector</li> <li>DC bus T-connector</li> <li>Bus-bar connectors, 55 mm, quantity 6</li> </ul>	<p>AC Bus T-connector DC Bus T-connector Bus-bar Connectors (6x)</p>
2198-H040-AP-T	T-connectors and bus-bars for the AC bus and control power on Frame 1 or 2 follower drives	<ul style="list-style-type: none"> <li>AC bus T-connector</li> <li>Control power T-connector</li> <li>Bus-bar connectors, 55 mm, quantity 6</li> </ul>	<p>AC Bus T-connector Control Power T-connector Bus-bar Connectors (6x)</p>
2198-H040-DP-T	T-connectors and bus-bars for the DC bus and control power on Frame 1 or 2 follower drives	<ul style="list-style-type: none"> <li>DC bus T-connector</li> <li>Control power T-connector</li> <li>Bus-bar connectors, 55 mm, quantity 4</li> </ul>	<p>DC Bus T-connector Control Power T-connector Bus-bar Connectors (4x)</p>
2198-H040-ADP-T	T-connectors and bus-bars for the AC bus, DC bus, and control power on Frame 1 or 2 follower drives	<ul style="list-style-type: none"> <li>AC bus T-connector</li> <li>DC bus T-connector</li> <li>Control power T-connector</li> <li>Bus-bar connectors, 55 mm, quantity 8</li> </ul>	<p>AC Bus T-connector DC Bus T-connector Control Power T-connector Bus-bar Connectors (8x)</p>

Use these connector kits when the first drive is frame 3 and the follower drive is also frame 3.

**Frame 3 Follower Drive Connector Kit Catalog Numbers**

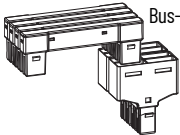
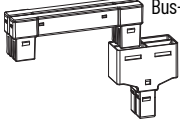
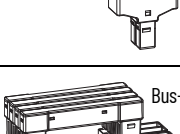
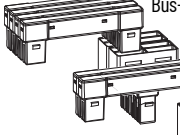
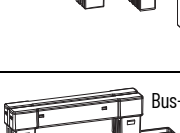
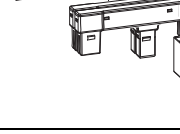
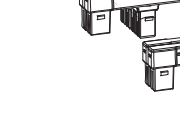
Kit Cat. No.	Description	Contents	Illustration
2198-H070-A-T	T-connector and bus-bars for the AC bus on Frame 3 follower drives	<ul style="list-style-type: none"> <li>• AC bus T-connector</li> <li>• Bus-bar connectors, 85 mm, quantity 4</li> </ul>	 <p>Bus-bar Connectors (4x) AC Bus T-connector</p>
2198-H070-D-T	T-connector and bus-bars for the DC bus on Frame 3 follower drives	<ul style="list-style-type: none"> <li>• DC bus T-connector</li> <li>• Bus-bar connectors, 85 mm, quantity 2</li> </ul>	 <p>Bus-bar Connectors (2x) T-connector</p>
2198-H070-P-T	T-connector and bus-bars for control power on Frame 3 follower drives	<ul style="list-style-type: none"> <li>• Control power T-connector</li> <li>• Bus-bar connectors, 85 mm, quantity 2</li> </ul>	 <p>Bus-bar Connectors (2x) Control Power T-connector</p>
2198-H070-AD-T	T-connectors and bus-bars for the AC and DC bus on Frame 3 follower drives	<ul style="list-style-type: none"> <li>• AC bus T-connector</li> <li>• DC bus T-connector</li> <li>• Bus-bar connectors, 85 mm, quantity 6</li> </ul>	 <p>Bus-bar Connectors (4x) AC Bus T-connector Bus-bar Connectors (2x) DC Bus T-connector</p>
2198-H070-AP-T	T-connectors and bus-bars for the AC bus and control power on Frame 3 follower drives	<ul style="list-style-type: none"> <li>• AC bus T-connector</li> <li>• Control power T-connector</li> <li>• Bus-bar connectors, 85 mm, quantity 6</li> </ul>	 <p>AC Bus T-connector Control Power T-connector Bus-bar Connectors (6x)</p>
2198-H070-DP-T	T-connectors and bus-bars for the DC bus and control power on Frame 3 follower drives	<ul style="list-style-type: none"> <li>• DC bus T-connector</li> <li>• Control power T-connector</li> <li>• Bus-bar connectors, 85 mm, quantity 4</li> </ul>	 <p>DC Bus T-connector Control Power T-connector Bus-bar Connectors (4x)</p>
2198-H070-ADP-T	T-connectors and bus-bars for the AC bus, DC bus, and control power on Frame 3 follower drives	<ul style="list-style-type: none"> <li>• AC bus T-connector</li> <li>• DC bus T-connector</li> <li>• Control power T-connector</li> <li>• Bus-bar connectors, 85 mm, quantity 8</li> </ul>	 <p>Bus-bar Connectors (4x) AC Bus T-connector Bus-bar Connectors (2x) DC Bus T-connector Bus-bar Connectors (2x) Control Power T-connector</p>

## Hiperface-to-DSL Feedback Converter Kit

The 2198-H2DCK Hiperface-to-DSL feedback kit (series B or later) converts 15-pin Hiperface encoder feedback signals to 2-pin DSL feedback signals. The following feedback types are accepted:

- Hiperface high-resolution absolute multi-turn and single-turn encoders
- Feedback-only axes (absolute single-turn/multi-turn Hiperface)

Use the converter kit for new installations with Kinetix 5500 servo drives and existing compatible motor/actuator installations when upgrading with Kinetix 5500 servo drives.

### Compatible Allen-Bradley Motors and Actuators

Rotary Motors	Linear Actuators	Kinetix 2090 Feedback Cables <sup>(1)</sup>
Kinetix MPL low-inertia motors	Kinetix LDAT integrated linear thrusters <sup>(2)</sup>	2090-CFBM7DF-CEAxx (standard, non-flex) 2090-CFBM7DF-CEAFxx (continuous-flex) 2090-XXNFMF-Sxx (standard, non-flex) 2090-CFBM7DF-CDAFxx (continuous-flex)
Kinetix MPL medium-inertia motors	Kinetix MPAS integrated linear stages <sup>(3)</sup>	
Kinetix MPF food-grade motors	Kinetix MPMA multi-axis linear stages <sup>(3)</sup>	
Kinetix MPS stainless-steel motors	Kinetix MPAR electric cylinders	
	Kinetix MPAL heavy-duty electric cylinders	

(1) These are typical feedback cables. Refer to the Kinetix 5500 Servo Drives Design Guide, publication [KNX-RM009](#), for the cables required for specific drive and motor/actuator combination.

(2) Kinetix LDAT linear thrusters with absolute high-resolution encoders are compatible. Linear stages with incremental encoders are not compatible.

(3) Kinetix MPAS and MPMA (ballscrew) linear stages are compatible. Direct-drive linear stages are not compatible.

**IMPORTANT** The 2198-H2DCK feedback converter kit is required for converting Hiperface feedback signals from the motor encoder to DSL feedback signals that are accepted by the Kinetix 5500 drive.

Compatible Allen-Bradley rotary motors and linear actuators must have high-resolution absolute encoders. Cable length restrictions also exist, refer to [Maximum Cable Lengths](#) on [page 78](#) for more information.

For product dimensions, refer to [Hiperface-to-DSL Feedback Converter Kit on page 143](#).

## Replacement Parts and Connector Kits - Kinetix 5500 Servo Drives

Replacement parts and kits available for Kinetix 5500 servo drives include the DSL feedback connector kit, power-sharing bus-bars, safety and digital input connectors, and power connector sets.

### DSL Feedback Connector Kit

The 2198-KITCON-DSL feedback connector kit is required for making feedback connections from Kinetix VP motors and actuators, and is included with each Kinetix 5500 servo drive. Motor power, brake, and the 2-wire feedback connections are made by using a single Kinetix 2090-CSxM1DF/DG cable. Refer to the Kinetix Rotary and Linear Motion Cable Specifications Technical Data, publication [KNX-TD004](#), for motor cable information.

#### DSL Feedback Connector Kit Features

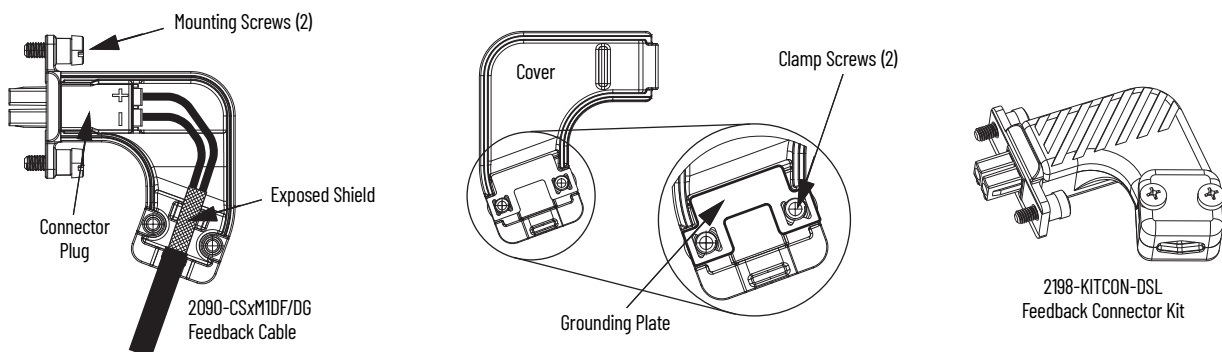

### Power-sharing Bus-bars and Connector Sets

Replacement Kit Cat. No.	Description	Contents	Illustration
2198-BARCON-85DCAC100	Replacement bus-bars for shared-bus connection system: • First drive is Frame 3 • Adjacent drive is Frame 3	Bus-bar connectors, 85 mm, quantity 8	
2198-BARCON-55DCAC100	Replacement bus-bars for shared-bus connection system: • First drive is Frame 1, 2, or 3 • Adjacent drive is Frame 1 or 2	Bus-bar connectors, 55 mm, quantity 8	
2198-KITCON-IO SP	Replacement IOD and STO connectors with spring clamp	<ul style="list-style-type: none"> <li>One (4-pin) digital inputs (IOD) connector</li> <li>One (5-pin) Safe Torque Off (STO) connector (two 5-pin connectors joined together)</li> </ul>	
2198-KITCON-IO SC	Replacement IOD and STO connectors with screw clamp		
2198-KITCON-PWR70	Replacement IDP, RC, CP, MP, and BC connectors for Frame 3 servo drives	<ul style="list-style-type: none"> <li>One AC input power (IPD) connector</li> <li>One shunt (RC) connector</li> <li>One control power (CP) connector</li> <li>One motor power (MP) connector</li> <li>One motor brake (BC) connector</li> </ul>	
2198-KITCON-PWR40	Replacement IDP, RC, CP, MP, and BC connectors for Frame 1 or 2 servo drives		
2198-KITCON-CAP1300	T-connectors and bus-bars for the DC bus and control power input on the 2198 capacitor module	<ul style="list-style-type: none"> <li>DC bus T-connector</li> <li>Control power T-connector</li> <li>Bus-bar connectors, 55 mm, quantity 4</li> </ul>	<p>Bus-bar Connectors (2x) DC Bus T-connector Bus-bar Connectors (2x) Control Power T-connector</p>

# Kinetix 5300 Single-axis EtherNet/IP Servo Drives



The Kinetix 5300 servo drives support integrated motion on the EtherNet/IP network. By using the Studio 5000 Logix Designer application and Logix 5000™ controllers, this cost-effective motion solution delivers high performance and scalability with Kinetix TLP servo motors that are matched to drive ratings for optimized system sizing. In addition, Kinetix 5300 drives also accept high-resolution and incremental feedback types that are required for many of the other Allen-Bradley rotary and linear products. The drive comes with standard inputs and hardwired Safe Torque Off with dual-port EtherNet/IP for various network topologies.

## Kinetix 5300 Drive Features and Indicators

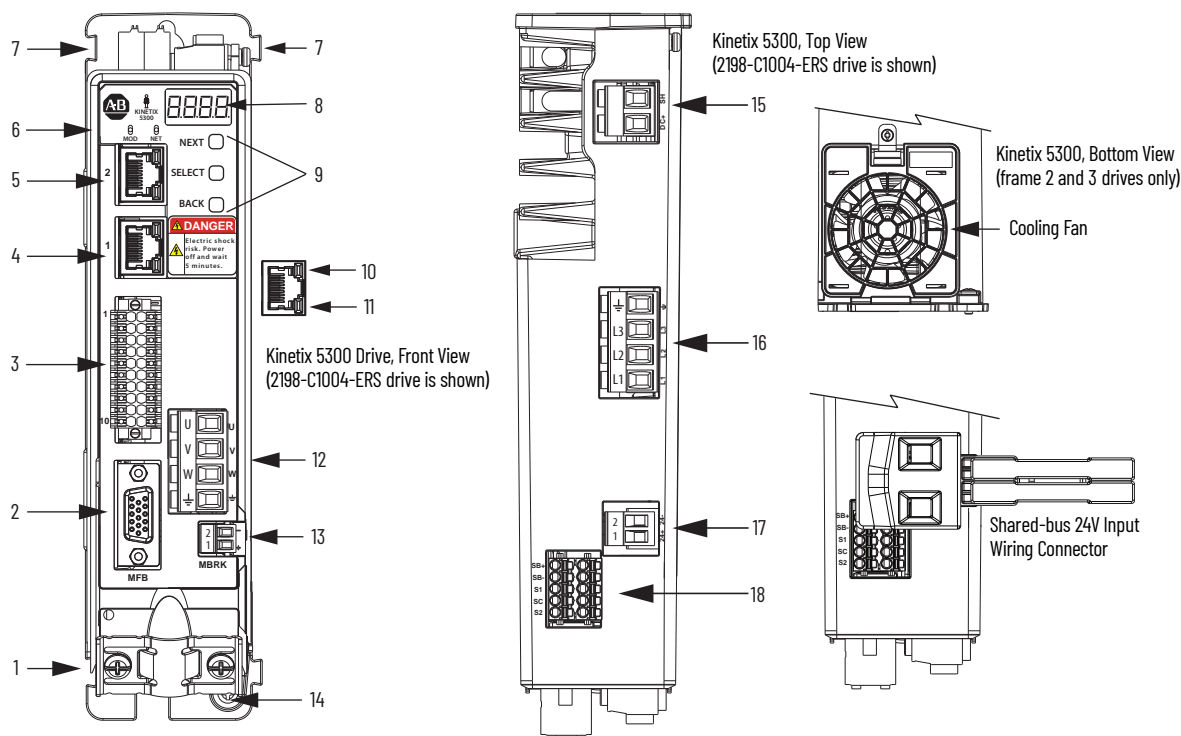

Item	Description
1	Motor cable shield clamp
2	Motor feedback (MFB) connector
3	Digital inputs and auxiliary feedback connector
4	Ethernet (PORT1) RJ45 connector
5	Ethernet (PORT2) RJ45 connector
6	Module and Network status indicators

Item	Description
7	Zero-stack mounting tab/cutout
8	Four-character status display
9	Navigation pushbuttons
10	Link speed status indicators
11	Link/Activity status indicators
12	Motor power connector

Item	Description
13	Motor brake connector
14	Ground terminal
15	Shunt resistor connector
16	AC mains input power connector
17	24V control input power connector
18	Safe torque-off (STO) connector

## Technical Specifications - Kinetix 5300 Servo Drives

### Kinetix 5300 (110 and 230V, single-phase and three-phase) Power Specifications

Attribute	2198-C1004-ERS	2198-C1007-ERS	2198-C1015-ERS	2198-C1020-ERS
AC input voltage	85...132V rms, single-phase (110V nom) 170...253V rms, single-phase (230V nom) 170...253V rms, three-phase (230V nom)			
AC input frequency	47...63 Hz			
Main AC input current (rms) <sup>(1)</sup>	2.17 A	3.56 A	6.58 A	9.45 A
Max inrush current (0-pk)				
Nom 110V input (single-phase)	6.0 A	6.0 A	6.0 A	6.0 A
Nom 230V input (single-phase)	11.5 A	11.5 A	11.5 A	11.5 A
Nom 230V input (three-phase)	7.4 A	7.4 A	7.4 A	7.4 A
Peak AC input current (rms)	6.99 A	10.48 A	19.75 A	27.46 A
Control power input voltage <sup>(2)</sup>	21.6...26.4V DC 24V DC nom			
Control power input current <sup>(1) (3)</sup> (non-brake motors)	0.4 A <sub>DC</sub>	0.4 A <sub>DC</sub>	0.9 A <sub>DC</sub>	0.9 A <sub>DC</sub>
Continuous output current (rms)				
Nom 110V input (single-phase)	2.8 A	4.6 A	8.5 A	12.2 A
Nom 230V input (single-phase)				
Nom 230V input (three-phase)				
Continuous output current (0-pk)				
Nom 110V input (single-phase)	4.0 A	6.5 A	12.0 A	17.3 A
Nom 230V input (single-phase)				
Nom 230V input (three-phase)				
Peak output current (rms) <sup>(4)</sup>				
Nom 110V input (single-phase)	6.6 A	9.7 A	12.2 A	25.0 A
Nom 230V input (single-phase)	9.5 A	15.5 A	20.5 A	40.6 A
Nom 230V input (three-phase)	9.5 A	15.5 A	29.2 A	40.6 A
Peak output current (0-pk)				
Nom 110V input (single-phase)	9.3 A	13.7 A	17.3 A	35.4 A
Nom 230V input (single-phase)				
Nom 230V input (three-phase)				
Line loss ride through	20 ms			
Continuous output power				
@ 110V nom single-phase	0.22 kW	0.36 kW	0.67 kW	0.97 kW
@ 230V nom single-phase	0.46 kW	0.76 kW	1.41 kW	2.02 kW
@ 230V nom three-phase	0.72 kW	1.18 kW	2.18 kW	3.13 kW
Internal shunt on	387.5V			
Internal shunt off	377.5V			
Internal shunt resistor	100 Ω	100 Ω	60 Ω	60 Ω
Internal shunt power	30 W	30 W	50 W	50 W
Bus undervoltage limit	72V @110V AC input 144V @230V AC input			
Bus overvoltage limit	405V			
Bus capacitance	330 μF	560 μF	660 μF	1120 μF
Capacitive energy absorption				
@ 110V nom AC input	21.31 J	36.17 J	42.63 J	72.34 J
@ 230V nom AC input				
@ 230V nom AC input	5.94 J	10.08 J	11.88 J	20.16 J
Efficiency				
@ 110V nom single-phase AC input	91%			
@ 230V nom single-phase AC input	95%			
@ 230V nom three-phase AC input	97%			
Short-circuit current rating	200,000 A (rms) symmetrical			

(1) Drives are limited to one power cycle per minute.

(2) The cooling fan runs as part of the control power startup routine, when the inverter is enabled, and if the inverter temperature exceeds preset threshold.

(3) For current values when motors include a holding brake, refer to [Control Power Current Specifications](#) on [page 95](#).

(4) Peak RMS current allowed for up to 1.0 seconds.



## Kinetix 5300 (230V, three-phase) Input Power Specifications

Attribute	2198-C2030-ERS	2198-C2055-ERS	2198-C2075-ERS
AC input voltage	170...253V rms, three-phase (230V nom)		
AC input frequency	47...63 Hz		
Main AC input current (rms) <sup>(1)</sup>	15.18 A	31.13 A	36.93 A
Max inrush current (0-pk)	7.4 A	14.8 A	14.8 A
Peak AC input current (rms)	41.26 A	73.06 A	86.25 A
Control power input voltage <sup>(2)</sup>	21.6...26.4V DC 24V DC nom		
Control power input current <sup>(1) (3)</sup> (non-brake motors)	0.9 A <sub>DC</sub>	1.7 A <sub>DC</sub>	1.7 A <sub>DC</sub>
Continuous output current (rms)	19.6 A	40.2 A	47.7 A
Continuous output current (0-pk)	27.7 A	56.9 A	67.5 A
Peak output current (rms) <sup>(4)</sup>	61.0 A	108.0 A	127.5 A
Peak output current (0-pk)	86.3 A	152.7 A	180.3 A
Line loss ride through	20 ms		
Continuous output power	5.02 kW	10.30 kW	12.22 kW
Internal shunt on	387.5V		
Internal shunt off	377.5V		
Internal shunt resistor	60 Ω	40 Ω	
Internal shunt power	50 W	75 W	
Bus undervoltage limit	144V		
Bus overvoltage limit	405V		
Bus capacitance	1680 μF	2460 μF	3280 μF
Capacitive energy absorption	30.25 J	44.29 J	59.05 J
Efficiency	97%		
Short-circuit current rating	200,000 A (rms) symmetrical		

(1) Drives are limited to one power cycle per minute.

(2) The cooling fan runs as part of the control power startup routine, when the inverter is enabled, and if the inverter temperature exceeds preset threshold.

(3) For current values when motors include a holding brake, refer to [Control Power Current Specifications](#) on [page 95](#).

(4) Peak RMS current allowed for up to 1.0 seconds.

## Kinetix 5300 (480V, three-phase) Input Power Specifications

Attribute	2198-C4004-ERS	2198-C4007-ERS	2198-C4015-ERS	2198-C4020-ERS
AC input voltage	342...528V rms, three-phase (480V nom)			
AC input frequency	47...63 Hz			
Main AC input current (rms) <sup>(1)</sup>	1.24 A	2.25 A	4.03 A	5.65 A
Max inrush current (0-pk)	15.5 A	15.5 A	15.5 A	15.5 A
Peak AC input current (rms)	3.59 A	6.29 A	12.18 A	16.10 A
Control power input voltage <sup>(2)</sup>	21.6...26.4V DC 24V DC nom			
Control power input current <sup>(1) (3)</sup> (non-brake motors)	0.4 A <sub>DC</sub>	0.4 A <sub>DC</sub>	0.9 A <sub>DC</sub>	0.9 A <sub>DC</sub>
Continuous output current (rms)	1.6 A	2.9 A	5.2 A	7.3 A
Continuous output current (0-pk)	2.3 A	4.1 A	7.4 A	10.3 A
Peak output current (rms) <sup>(4)</sup>	5.3 A	9.3 A	18.0 A	23.8 A
Peak output current (0-pk)	7.5 A	13.2 A	25.5 A	33.7 A
Line loss ride through	20 ms			
Continuous output power	0.86 kW	1.55 kW	2.78 kW	3.90 kW
Internal shunt on	775V			

Attribute	2198-C4004-ERS	2198-C4007-ERS	2198-C4015-ERS	2198-C4020-ERS
Internal shunt off	765V			
Internal shunt resistor	100 Ω	100 Ω	60 Ω	60 Ω
Internal shunt power	30 W	30 W	50 W	50 W
Bus undervoltage limit	275V			
Bus overvoltage limit	810V			
Bus capacitance	165 μF	165 μF	280 μF	330 μF
Capacitive energy absorption	8.13 J		13.79 J	16.26 J
Efficiency	97%			
Short-circuit current rating	200,000 A (rms) symmetrical			

- (1) Drives are limited to one power cycle per minute.
- (2) The cooling fan runs as part of the control power startup routine, when the inverter is enabled, and if the inverter temperature exceeds preset threshold.
- (3) For current values when motors include a holding brake, refer to [Control Power Current Specifications](#) on [page 95](#).
- (4) Peak RMS current allowed for up to 1.0 seconds.

**Kinetix 5300 (480V, three-phase) Input Power Specifications (continued)**

Attribute	2198-C4030-ERS	2198-C4055-ERS	2198-C4075-ERS
AC input voltage	342...528V rms, three-phase (480V nom)		
AC input frequency	47...63 Hz		
Main AC input current (rms) <sup>(1)</sup>	9.06 A	17.50 A	21.29 A
Max inrush current (0-pk)	30.9 A	30.9 A	46.4 A
Peak AC input current (rms)	23.07 A	39.57 A	49.72 A
Control power input voltage <sup>(2)</sup>	21.6...26.4V DC 24V DC nom		
Control power input current <sup>(1) (3)</sup> (non-brake motors)	0.9 A <sub>DC</sub>	1.7 A <sub>DC</sub>	1.7 A <sub>DC</sub>
Continuous output current (rms)	11.7 A	22.6 A	27.5 A
Continuous output current (0-pk)	16.5 A	32.0 A	38.9 A
Peak output current (rms) <sup>(4)</sup>	34.1 A	58.5 A	73.5 A
Peak output current (0-pk)	48.3 A	82.7 A	103.9 A
Line loss ride through	20 ms		
Continuous output power	6.25 kW	12.08 kW	14.70 kW
Internal shunt on	775V		
Internal shunt off	765V		
Internal shunt resistor	60 Ω	40 Ω	
Internal shunt power	50 W	75 W	
Bus undervoltage limit	275V		
Bus overvoltage limit	810V		
Bus capacitance	560 μF	820 μF	1230 μF
Capacitive energy absorption	27.59 J	40.40 J	60.60 J
Efficiency	97%		
Short-circuit current rating	200,000 A (rms) symmetrical		

- (1) Drives are limited to one power cycle per minute.
- (2) The cooling fan runs as part of the control power startup routine, when the inverter is enabled, and if the inverter temperature exceeds preset threshold.
- (3) For current values when motors include a holding brake, refer to [Control Power Current Specifications](#) on [page 95](#).
- (4) Peak RMS current allowed for up to 1.0 seconds.

## Control Power Current Specifications

Kinetix 5300 servo drives have different 24V DC power consumption. Factors to consider when calculating the combined current demand from your 24V DC power supply include the following:

- Catalog number for each drive in the system
- Whether servo motors include the holding brake option

### Control Power Current Specifications

Kinetix 5300 Drive Cat. No.	24V Current per Module (non-brake motor) A <sub>DC</sub>	24V Current (2 A brake motor) <sup>(1)</sup> A <sub>DC</sub>	24V Inrush Current <sup>(2)</sup> A
2198-C1004-ERS	0.4	2.4	1.8
2198-C1007-ERS			
2198-C4004-ERS			
2198-C4007-ERS			
2198-C1015-ERS	0.9	2.9	2.4
2198-C1020-ERS			
2198-C2030-ERS			
2198-C4015-ERS			
2198-C4020-ERS			
2198-C4030-ERS	1.7	3.7	3.0
2198-C2055-ERS			
2198-C2075-ERS			
2198-C4055-ERS			
2198-C4075-ERS			

(1) See Kinetix Rotary Motion Specifications Technical Data, publication [KNX-TD001](#), for brake current specifications of Kinetix MP, TLP, and TL/TLY rotary motors.

(2) Inrush current duration is less than 30 ms.

## Peak Current Specifications

### Load Duty-cycle Profile Example

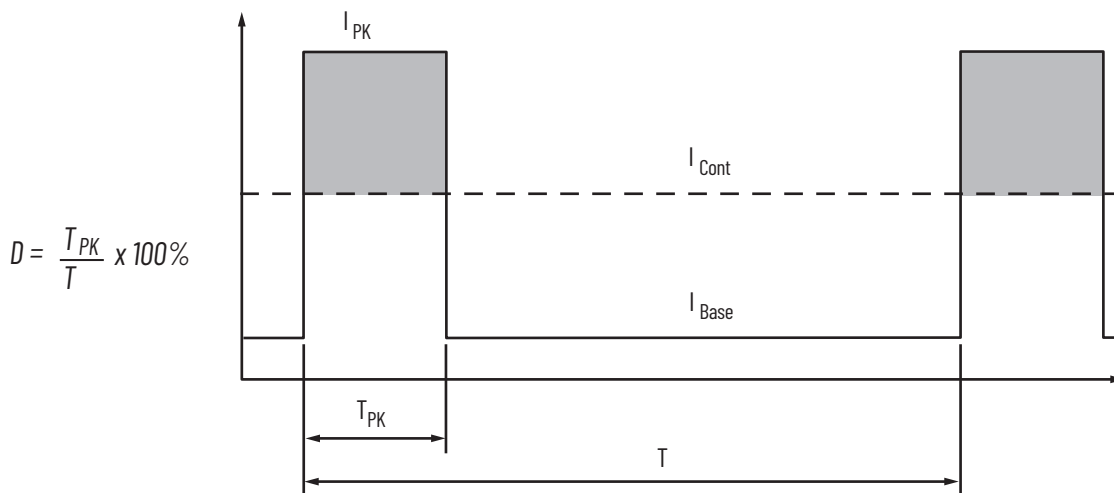

### Peak Duty Cycle Definition of Terms

Term	Definition <sup>(1)</sup>
Continuous Current Rating ( $I_{Cont}$ )	The maximum value of current that can be output continuously.
Peak Current Rating ( $I_{PKmax}$ )	The maximum value of peak current that the drive can output. This rating is valid only for overload times less than $T_{PKmax}$ .
Duty Cycle (D)	The ratio of time at peak to the Application Period is defined as: $D = \frac{T_{PK}}{T} \times 100\%$
Time at Peak ( $T_{PK}$ )	The time at peak current ( $I_{PK}$ ) for a given loading profile. Must be less than or equal to $T_{PKmax}$ .
Peak Current ( $I_{PK}$ )	The level of peak current for a given loading profile. $I_{PK}$ must be less than or equal to the Peak Current Rating ( $T_{PKmax}$ ) of the drive.
Base Current ( $I_{Base}$ )	The level of current between the pulses of peak current for a given loading profile. $I_{Base}$ must be less than or equal to the continuous current rating ( $I_{Cont}$ ) of the drive.
Loading Profile	The loading profile is composed of $I_{PK}$ , $I_{Base}$ , $T_{PK}$ , and D (or T) values and completely specify the operation of the drive in an overload situation. These values are collectively defined as the Loading Profile of the drive.
Application Period (T)	The sum of the times at $I_{PK}$ ( $T_{PK}$ ) and $I_{Base}$ .

(1) All current values are specified as RMS.

For more information on system sizing and selection, see the FactoryTalk<sup>®</sup> Motion Analyzer website [rok.auto/motion-analyzer](http://rok.auto/motion-analyzer)

Peak Inverter Overload ( $T_{PK} < 1.0$  s)

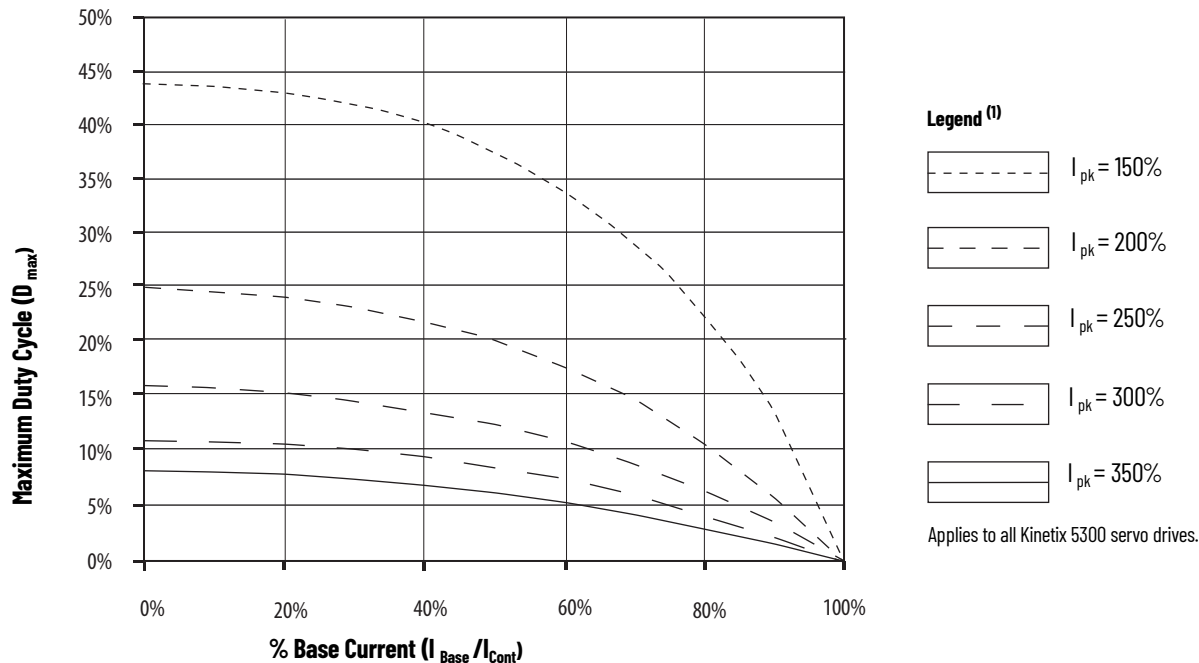

(1) Base current ( $I_{Base}$ ) and peak current ( $I_{pk}$ ) are a percentage of the continuous drive current rating ( $I_{Cont}$ ).

## Circuit Breaker/Fuse Specifications

The Kinetix 5300 drives use internal solid-state motor short-circuit protection and, when protected by suitable branch circuit protection, are rated for use on a circuit capable of delivering up to 200,000 A (fuses, UL applications), 10,000 A (miniature circuit breakers), and 65,000 A (molded-case circuit breakers).

### Kinetix 5300 UL/CSA Circuit Protection Specifications

Drive Cat. No.	AC Input Voltage, nom	Phase	Bussmann Fuses Cat. No.	Molded Case CB Cat. No.
2198-C1004-ERS	200...240V AC	Three phase	KTK-R-6	140U-D6D3-B40 140UT-D7D3-B40
2198-C1007-ERS			KTK-R-10	140U-D6D3-B80 140UT-D7D3-B80
2198-C1015-ERS			KTK-R-15	140U-D6D3-C12 140UT-D7D3-C12
2198-C1020-ERS			KTK-R-25	140U-D6D3-C20 140UT-D7D3-C20
2198-C2030-ERS			KTK-R-30	140U-D6D3-C30 140UT-D7D3-C30
2198-C2055-ERS			LPJ-50SP	140G-G6C3-C50
2198-C2075-ERS			LPJ-60SP	140G-G6C3-C60
2198-C4004-ERS	380...480V AC	Three phase	KTK-R-3	140U-D6D3-B20 140UT-D7D3-B20
2198-C4007-ERS			KTK-R-6	140U-D6D3-B40 140UT-D7D3-B40
2198-C4015-ERS			KTK-R-12	140U-D6D3-B80 140UT-D7D3-B80
2198-C4020-ERS			KTK-R-15	140U-D6D3-C12 140UT-D7D3-C12
2198-C4030-ERS			KTK-R-25	140U-D6D3-C15 140UT-D7D3-C15
2198-C4055-ERS			LPJ-30SP	140U-D6D3-C30 140UT-D7D3-C30
2198-C4075-ERS			LPJ-35SP	140U-D6D3-C30 140UT-D7D3-C30
2198-C1004-ERS	100...120V AC	Single phase	KTK-R-6	140U-D6D2-B40 140UT-D7D3-B80
2198-C1007-ERS			KTK-R-10	140U-D6D2-B80 140UT-D7D3-B80
2198-C1015-ERS			KTK-R-15	140U-D6D2-C12 140UT-D7D3-C12
2198-C1020-ERS	200...240V AC	Single phase	KTK-R-25	140U-D6D2-C20 140UT-D7D3-C20
2198-C1004-ERS			KTK-R-6	140U-D6D2-B40 140UT-D7D3-B40
2198-C1007-ERS			KTK-R-10	140U-D6D2-B80 140UT-D7D3-B80
2198-C1015-ERS			KTK-R-15	140U-D6D2-C12 140UT-D7D3-C12
2198-C1020-ERS			KTK-R-25	140U-D6D2-C20 140UT-D7D3-C20

## Kinetix 5300 IEC (non-UL/CSA) Circuit Protection Specifications

Drive Cat. No.	AC Input Voltage, nom	Phase	DIN gG Fuses Amps, max	Miniature CB Cat. No.	Molded Case CB Cat. No.
2198-C1004-ERS	200...240V AC		6	1489-M3C060	140U-D6D3-B40 140UT-D7D3-B40
2198-C1007-ERS			10	1489-M3C100	140U-D6D3-B80 140UT-D7D3-B80
2198-C1015-ERS			16	1489-M3C160	140U-D6D3-C12 140UT-D7D3-C12
2198-C1020-ERS			25	1489-M3C250	140U-D6D3-C20 140UT-D7D3-C20
2198-C2030-ERS			32	1489-M3C400	140U-D6D3-C30 140UT-D7D3-C30
2198-C2055-ERS			40	-	140G-G6C3-C50
2198-C2075-ERS			50	-	140G-G6C3-C60
2198-C4004-ERS	380...480V AC	Three phase	2	1489-M3C030	140U-D6D3-B20 140UT-D7D3-B20
2198-C4007-ERS			6	1489-M3C060	140U-D6D3-B40 140UT-D7D3-B40
2198-C4015-ERS			12	1489-M3C100	140U-D6D3-B80 140UT-D7D3-B80
2198-C4020-ERS			16	1489-M3C130	140U-D6D3-C12 140UT-D7D3-C12
2198-C4030-ERS			25	1489-M3C200	140U-D6D3-C15 140UT-D7D3-C15
2198-C4055-ERS			32	1489-M3C350	140U-D6D3-C30 140UT-D7D3-C30
2198-C4075-ERS			32	1489-M3C400	140U-D6D3-C30 140UT-D7D3-C30
2198-C1004-ERS	100...120V AC	Single phase	6	1489-M2C060	140U-D6D2-B40 140UT-D7D2-B40
2198-C1007-ERS			10	1489-M2C100	140U-D6D2-B80 140UT-D7D2-B80
2198-C1015-ERS			16	1489-M2C160	140U-D6D2-C12 140UT-D7D2-C12
2198-C1020-ERS			25	1489-M2C250	140U-D6D2-C20 140UT-D7D2-C20
2198-C1004-ERS	200...240V AC		6	1489-M2C060	140U-D6D2-B40 140UT-D7D2-B40
2198-C1007-ERS			10	1489-M2C100	140U-D6D2-B80 140UT-D7D2-B80
2198-C1015-ERS			16	1489-M2C160	140U-D6D2-C12 140UT-D7D2-C12
2198-C1020-ERS			25	1489-M2C250	140U-D6D2-C20 140UT-D7D2-C20

## Power Dissipation Specifications

Use this table to size an enclosure and calculate required ventilation for your Kinetix 5300 drive system.

Kinetix 5300 Drive Cat. No.	AC Input, nom	Usage as a % of Rated Power Output <sup>(1)</sup> (watts)				
		20%	40%	60%	80%	100%
2198-C1004-ERS	200...240V three-phase	12	16	20	25	29
2198-C1007-ERS		14	19	24	30	37
2198-C1015-ERS		26	36	47	59	71
2198-C1020-ERS		35	52	71	91	112
2198-C2030-ERS		53	87	124	164	206
2198-C2055-ERS		87	139	193	250	308
2198-C2075-ERS		97	159	225	293	364
2198-C4004-ERS	380...480V three-phase	16	21	26	31	36
2198-C4007-ERS		20	30	39	48	58
2198-C4015-ERS		33	48	62	78	93
2198-C4020-ERS		39	58	79	101	124
2198-C4030-ERS		57	89	123	157	193
2198-C4055-ERS		112	171	231	293	356
2198-C4075-ERS		134	204	273	344	417
2198-C1004-ERS	200...240V single-phase	12	16	20	25	30
2198-C1007-ERS		14	19	24	30	37
2198-C1015-ERS		25	36	47	59	72
2198-C1020-ERS		35	52	72	92	115
2198-C1004-ERS	100...120V single-phase	11	14	18	22	26
2198-C1007-ERS		12	17	21	27	32
2198-C1015-ERS		23	32	42	53	64
2198-C1020-ERS		30	44	59	77	96

(1) Internal shunt power is not included in the calculations and must be added based on utilization.

## Weight Specifications

Kinetix 5300 Drive Cat. No.	Frame Size	Weight, approx kg (lb)
2198-C1004-ERS	1	1.30 (2.87)
2198-C1007-ERS		1.34 (2.95)
2198-C1015-ERS	2	1.85 (4.08)
2198-C1020-ERS		1.91 (4.21)
2198-C2030-ERS		2.02 (4.45)
2198-C2055-ERS	3	3.54 (7.80)
2198-C2075-ERS		3.60 (7.94)
2198-C4004-ERS	1	1.34 (2.95)
2198-C4007-ERS		1.34 (2.95)
2198-C4015-ERS	2	1.89 (4.17)
2198-C4020-ERS		1.93 (4.25)
2198-C4030-ERS		2.05 (4.52)
2198-C4055-ERS	3	3.60 (7.94)
2198-C4075-ERS		3.81 (8.40)



## Maximum Cable Lengths

The Kinetix 5300 drive maximum cable length depends on feedback type and input voltage used in the application. These tables assume the use of recommended cables as shown in the Kinetix Rotary and Linear Motion Cable Specifications Technical Data, publication [KNX-TD004](#).

Compatible Motor and Actuator Cat. No.	Feedback Type <sup>(1)</sup>	Cable Length, max m (ft)		
		≤ 400V AC Input	480V AC Input	
TLP-A/Bxxx-xxx-D	Nikon (24-bit) absolute high-resolution, multi-turn and single-turn	50 (164)		
MPL-A/B15xxx-V/Ex7xAA MPL-A/B2xxx-V/Ex7xAA	Hiperface, absolute high-resolution, multi-turn and single-turn	50 (164)	20 (65.6)	
MPL-A/B3xxx-S/Mx7xAA MPL-A/B4xxx-S/Mx7xAA MPL-A/B45xxx-S/Mx7xAA MPL-A/B5xxx-S/Mx7xAA MPL-B6xxx-S/Mx7xAA MPL-B8xxx-S/Mx7xAA MPL-B9xxx-S/Mx7xAA		50 (164)		
MPM-A/Bxxxx-S/M MPF-A/Bxxxx-S/M MPS-A/Bxxxx-S/M				
MPAR-A/B3xxxx-M				
MPAS-A/Bxxxx1-V05SxA (ballscrew) MPAS-A/Bxxxx2-V20SxA (ballscrew) MPAR-A/B1xxxx-V and MPAR-A/B2xxxx-V (series B) MPAI-A/BxxxxM3		50 (164)	20 (65.6)	
MPL-A/B15xxx-Hx7xAA MPL-A/B2xxx-Hx7xAA		Incremental encoder	30 (98.4)	20 (65.6)
MPL-A/B3xxx-Hx7xAA MPL-A/B4xxx-Hx7xAA MPL-A/B45xxx-Hx7xAA				
MPAS-A/Bxxxx-ALMx2C (direct drive)	30 (98.4)			
TLY-Axxxx-B	Tamagawa (17-bit) absolute high-resolution, multi-turn			
TL-Axxxx-B				
TLY-Axxxx-H	Incremental encoder			
LDAT-Sxxxxx-xDx	Hiperface, absolute, magnetic scale			
LDAT-Sxxxxx-xBx	Incremental, magnetic scale	10 (33.1)		
LDC-Cxxxxx-xH, LDL-xxxxxx-xH	Sin/Cos or TTL encoder			

(1) For motors with incremental feedback, the maximum motor cable length is 30 m (98 ft).

## Dimensions - Kinetix 5300 Servo Drives

These drawings provide mounting dimensions for Kinetix 5300 servo drives. The 2198-K53CK-D15M feedback connector kit is available for Kinetix 5300 servo drives when flying-lead cable is used with compatible motors and actuators. Mounting dimensions that include the feedback connector kit or drive-end cable connector are also shown.

### Kinetix 5300 Drives with 2198-K53CK-D15M Connector Kit

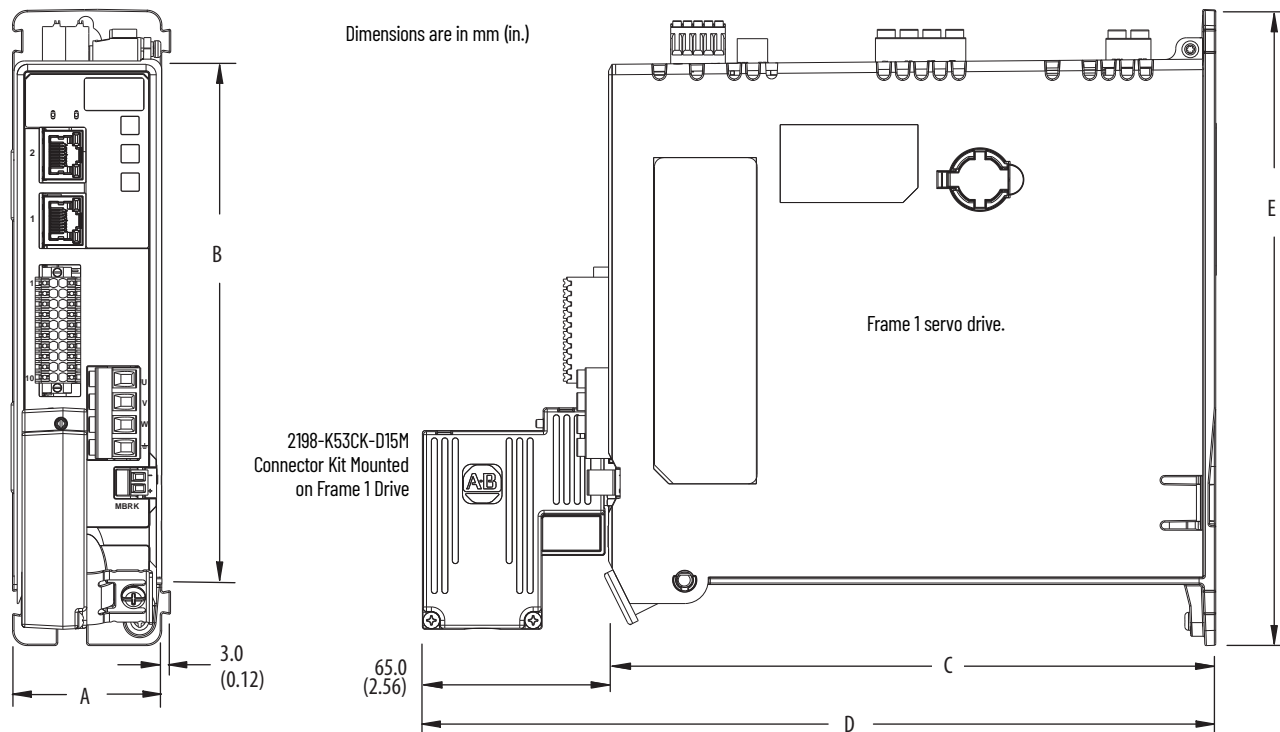

200V-class Drives Cat. No.	400V-class Drives Cat. No.	Frame Size	A mm (in.)	B mm (in.)	C mm (in.)	D mm (in.)	E mm (in.)
2198-C1004-ERS	2198-C4004-ERS	Frame 1	50.0 (1.97)	175 (6.89)	204 (8.03)	265 (10.43)	215 (8.46)
2198-C1007-ERS	2198-C4007-ERS						265 (10.43)
2198-C1015-ERS	2198-C4015-ERS						265 (10.43)
2198-C1020-ERS	2198-C4020-ERS	Frame 2	55.0 (2.16)	225 (8.86)	204 (8.03)	265 (10.43)	265 (10.43)
2198-C2030-ERS	2198-C4030-ERS						265 (10.43)
2198-C2055-ERS	2198-C4055-ERS	Frame 3	85.2 (3.35)	250 (9.84)	204 (8.03)	265 (10.43)	294 (11.57)
2198-C2075-ERS	2198-C4075-ERS						294 (11.57)

Refer to [Kinetix 5300 Drives with Connector Kit Accessories \(Frames 2 and 3\)](#) on [page 103](#) for product dimensions when the connector kit or drive-end cable connector is used with frame 2 and 3 servo drives.

Kinetix 5300 Drives with Connector Kit Accessories (Frames 2 and 3)

Dimensions are in mm (in.)

2198-K53CK-D15M  
Feedback Connector Kit  
Mounted on Kinetix 5300 Frame 3 Drive

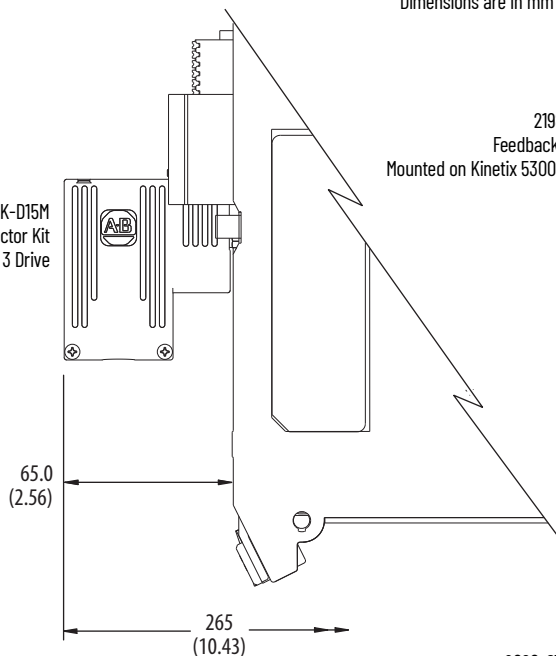

2198-K53CK-D15M  
Feedback Connector Kit  
Mounted on Kinetix 5300 Frame 2 Drive

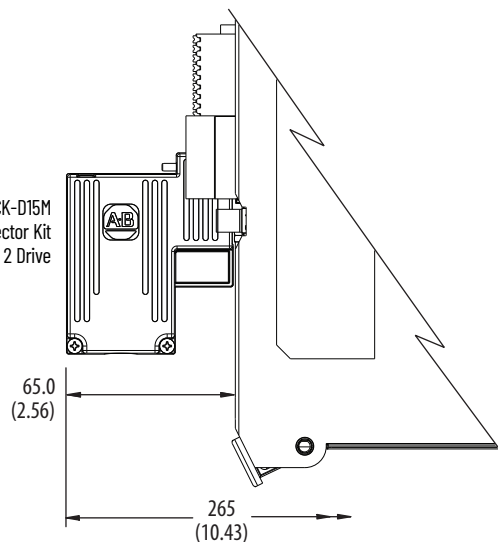

Frame 3 clamping plate for  
large diameter cables.

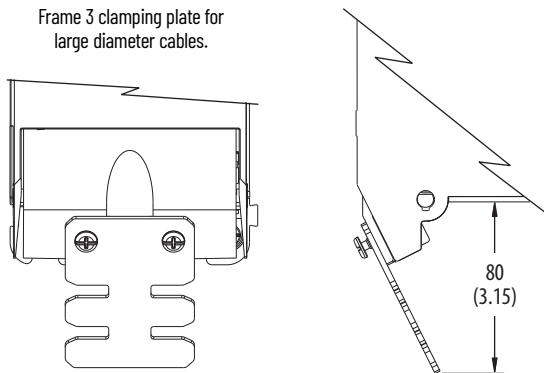

2090-CTFB-MxDD  
Feedback Cable

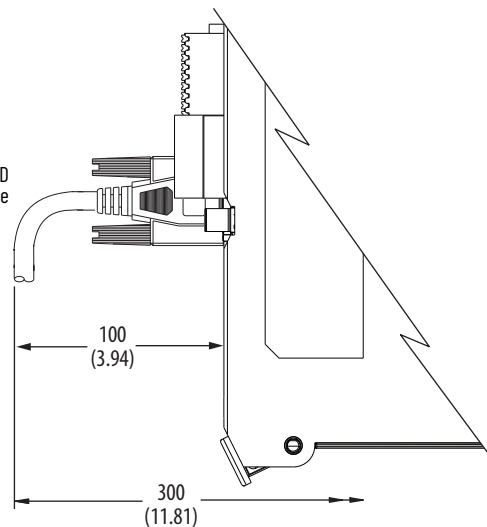

Clearance required for drive-end cable  
connectors apply to all frame sizes.

2090-CFBM7DD-CEAxxx  
Feedback Cable (drive-end connector)

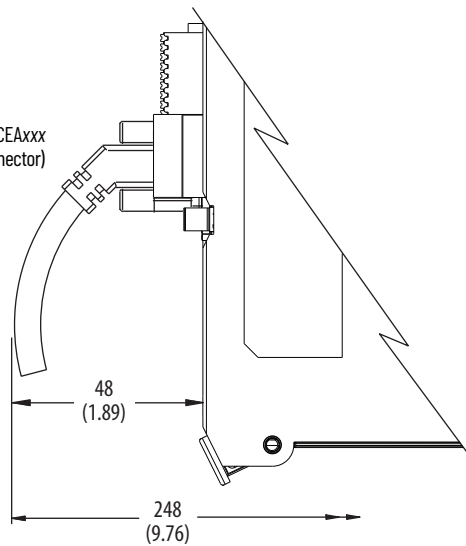

## Environmental Specifications - Kinetix 5300 Servo Drives

Attribute	Operational Range	Storage Range (nonoperating)
Ambient temperature	0...50 °C (32...122 °F)	-35...+70 °C (-31...+158 °F)
Relative humidity	5...85% noncondensing	5...95% noncondensing
Protection class (IEC 60529)	IP20	
Degree of pollution (IEC 61800-5-1)	2	
Altitude	1000 m (3281 ft)	1000 m (3281 ft)
Vibration	5...55 Hz @ 0.35 mm (0.014 in.) double amplitude, continuous displacement; 55...500 Hz @ 2.0 g peak constant acceleration (ten sweeps in each of three mutually perpendicular directions)	
Shock	15 g, 11 ms half-sine pulse (3 pulses in each direction of 3 mutually perpendicular directions)	

## Certifications - Kinetix 5300 Servo Drives

Agency Certification <sup>(1)</sup>	Standards
cULus <sup>(2)</sup>	UL Listed to U.S. and Canadian safety standards (UL61800-5-1 File E59272). Solid-state motor overload protection provides dynamic fold-back of motor current when 110% of the motor rating is reached with a peak current limit based on the peak rating of the motor as investigated by UL to comply with (UL61800-5-1 File E59272).
CE	European Union 2004/108/EC EMC Directive compliant with IEC 61800-3:2004 + A1:2012: Adjustable Speed Electrical Power Drive Systems - Part 3; EMC Product Standard including specific test methods. European Union 2006/95/EC Low Voltage Directive compliant with IEC 61800-5-1:2007 - Adjustable speed electrical power drive systems.
Functional Safety	TÜV certified for functional safety when used as described in the Kinetix 5300 Servo Drives User Manual, publication <a href="#">2198-UM005</a> . 2198-Cxxx-ERS (hardwired safety) drive ratings: up to Performance Level (PL) d, Category 3 according to ISO 13849; up to SIL CL2 according to IEC 61508, IEC 61800-5-2, and IEC 62061.
RCM	Australian Radiocommunications Act, compliant with: <ul style="list-style-type: none"> <li>• Radiocommunications Act: 1992 (including Amendments up to 2017)</li> <li>• Radiocommunications (Electromagnetic Compatibility) Standard: 2017</li> <li>• Radiocommunications Labeling ((Compliance Labelling - Incidental Emissions) Notice: 2017</li> <li>• AS/NZS CISPR 11: 2002 (Group 1, Class A)</li> </ul>
KC	Korean Registration of Broadcasting and Communications Equipment, compliant with: <ul style="list-style-type: none"> <li>• Article 58-2 of Radio Waves Act, Clause 3</li> <li>• Registration number: KCC-REM-RAA-2198</li> </ul>
ODVA	<ul style="list-style-type: none"> <li>• EtherNet/IP conformance tested</li> <li>• CIP Security conformance tested</li> </ul>
OSHA	Maximum audible noise from the servo drive system complies with OSHA standard 3074, Hearing Conservation (<85 dBA).
Ecodesign	IE2 efficiency class per Ecodesign regulation EU 2019/1781

(1) See [rok.auto/certifications](#) for declarations of conformity, certificates, and other certification details.

(2) UL has not evaluated the Safe Torque Off option in these products.

## Accessories - Kinetix 5300 Servo Drives

Kinetix 5300 drive accessories include the 2198 and 2097 external shunt resistors, AC line filters, the 24V shared-bus connection system, and feedback connector kit.

### Shunt Resistor

The 2097-Rx and 2198-Rxxx external passive shunts are available to provide additional shunt capacity for applications where the internal shunt capacity is exceeded.

- Catalog numbers 2198-R014 and 2198-R031 are composed of resistor coils that are housed inside an enclosure.
- Catalog numbers 2198-R004, 2097-R6, and 2198-R7 are shunt resistors without an enclosure.

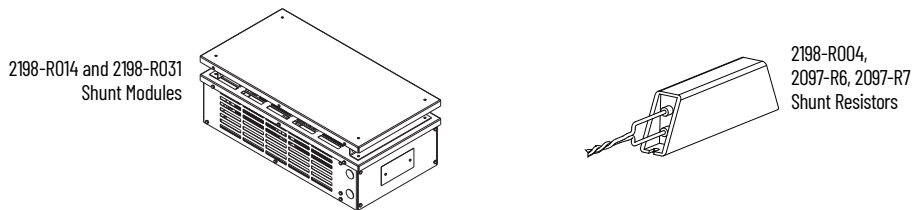

### Passive-shunt and Drive Compatibility

Drive Cat. No.	Internal Shunt Specifications		2198 External Shunt Module <sup>(1)</sup> Cat. No.			2097 External Shunt Module <sup>(1)</sup> Cat. No.	
	$\Omega$	W	2198-R004	2198-R014	2198-R031	2097-R6	2097-R7
2198-C1004-ERS	100	30	-	-	-	X	X
2198-C1007-ERS			-	-	-	X	X
2198-C1015-ERS	60	50	X	-	X	X	X
2198-C1020-ERS			X	-	X	X	X
2198-C2030-ERS			X	-	X	X	X
2198-C2055-ERS	40	75	X	X	X	X	X
2198-C2075-ERS			X	X	X	X	X
2198-C4004-ERS	100	30	-	-	-	X	X
2198-C4007-ERS			-	-	-	X	X
2198-C4015-ERS	60	50	X	-	X	X	X
2198-C4020-ERS			X	-	X	X	X
2198-C4030-ERS			X	-	X	X	X
2198-C4055-ERS	40	75	X	X	X	X	X
2198-C4075-ERS			X	X	X	X	X

(1) Shunt resistor selection is based on the needs of your actual hardware configuration.

### Shunt Module Specifications

Shunt Module Cat. No.	Resistance Ohms	Continuous Power W	Weight, approx kg (lb)
2097-R6	75	150	0.3 (0.7)
2097-R7	150	80	0.2 (0.4)
2198-R004	33	400	1.8 (4.0)
2198-R014	9.4	1400	9.1 (20)
2198-R031	33	3100 <sup>(1)</sup>	16.8 (37)

(1) The 2198-R031 shunt is limited to 2000 W when used with 2198-C1015-ERS, 2198-C1020-ERS, 2198-C2030-ERS, 2198-C4015-ERS, 2198-C4020-ERS, 2198-C4030-ERS (frame 2) drives.

Refer to [Passive Shunt Modules and Resistors Dimensions on page 135](#) for product dimensions and additional specifications.

## AC Line Filters

The Kinetix 5300 drives were tested by using these recommended line filters and are required to meet CE requirements. These Kinetix 2198 AC line filters apply to Kinetix 5300 drives used in single-phase and three-phase operation.

See [AC Line Filter Dimensions and Specifications on page 138](#) for product dimensions and additional specifications.

### AC Line Filter Selection

Drive Cat. No.	Frame Size	AC Line Filter Cat. No.
2198-C1004-ERS	1	2198-DB08-F
2198-C1007-ERS		
2198-C1015-ERS	2	2198-DBR20-F
2198-C1020-ERS		
2198-C2030-ERS		
2198-C2055-ERS	3	2198-DBR40-F
2198-C2075-ERS		
2198-C4004-ERS	1	2198-DB08-F
2198-C4007-ERS		
2198-C4015-ERS	2	2198-DBR20-F
2198-C4020-ERS		
2198-C4030-ERS		
2198-C4055-ERS	3	2198-DBR40-F
2198-C4075-ERS		

### 2198-DBxx-F AC Line Filter Specifications

AC Line Filter Cat. No.	Voltage Rating, max	Current Rating A @ 50 °C (122 °F)	Power Loss W	Leakage Current mA	Weight, approx kg (lb)	Operating Temperature
2198-DB08-F <sup>(1)</sup>	528V AC three-phase 50/60 Hz	7.5	3.6	2.5	0.77 (1.70)	0...50 °C (32...122 °F)
2198-DBR20-F		20	4.2	30.0	1.0 (2.20)	
2198-DBR40-F		54	15.0		3.3 (7.28)	

(1) Applies to installations with single-phase or three-phase input power.

## 24V Shared-bus Connection System

Kinetix 5300 drives can use the zero-stack feature with the 24V DC shared-bus connection system to extend control power to multiple drives.

**IMPORTANT** When the 24V shared-bus connection system is used, the zero-stack tab and cutout must be engaged between adjacent drives.

The shared-bus connection system is composed of three components:

- Input wiring connectors that plug into the leftmost drive and receive input wiring for 24V DC.
- 24V DC T-connectors that plug into the drives downstream from where 24V control power is input.
- Bus bars that connect between drives to extend the 24V DC control power from drive-to-drive.

### Shared-bus Connection System Example

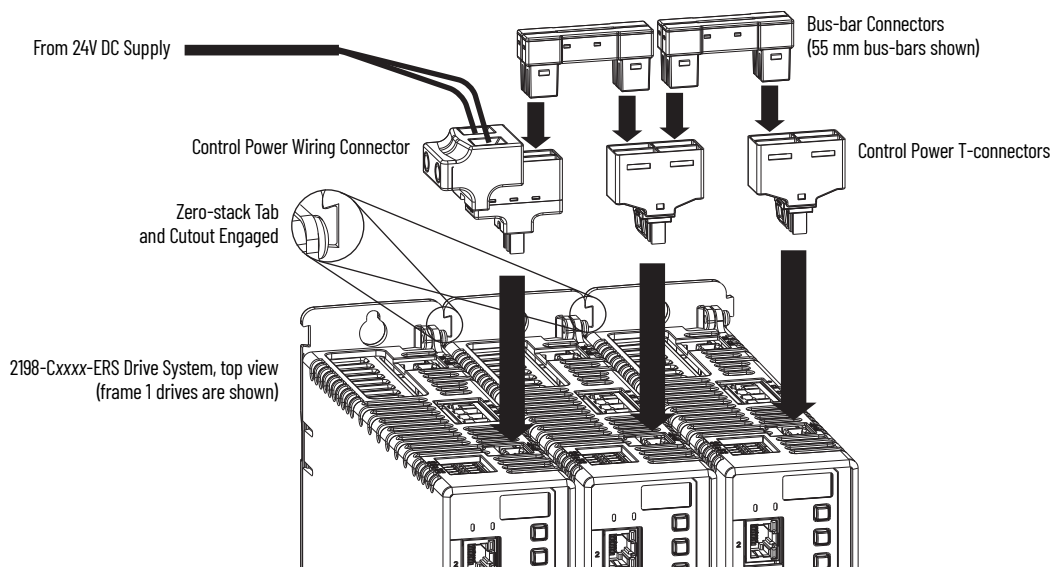

### 24V Shared-bus Connector Kit Catalog Numbers

Kit Cat. No.	Frame Size	Description	Illustration
2198-TCON-24VDCIN36	1, 2, or 3	Control power (24V) input wiring connector	Control Power Input Connector
2198-H040-P-T	1 or 2	<ul style="list-style-type: none"> <li>• Control power T-connector</li> <li>• Bus-bar connectors, quantity 2</li> </ul>	Bus-bar Connectors (2x) T-connector
2198-H070-P-T	3	<ul style="list-style-type: none"> <li>• Control power T-connector</li> <li>• Bus-bar connectors, quantity 2</li> </ul>	Bus-bar Connectors (2x) T-connector

## Kinetix 5300 Feedback Connector Kit

The 2198-K53CK-D15M connector kit passes feedback signals straight through from the encoder to the (MFB) feedback connector on the drive. The following encoder feedback types are accepted:

- Hiperface high-resolution absolute (multi-turn and single-turn)
- Nikon (24-bit) high-resolution serial encoder
- Tamagawa (17-bit) high-resolution serial encoder
- Digital AqB (TTL) with UVW (incremental)
- Generic sin/cos with UVW (incremental)

Use the feedback connector kit in the following types of installations:

- New installations with Kinetix 5300 servo drives and the compatible motors and actuators with flying lead cables
- Existing motor/actuator installations when upgrading with Kinetix 5300 servo drives

### Compatible Allen-Bradley Motors and Actuators

Rotary Motors	Kinetix 2090 Feedback Cables <sup>(1)</sup>	
	High-resolution Encoder	Incremental Encoder
TLP-A046-xxx, TLP-A/B070-xxx, TLP-A/B090-xxx, TLP-A100-xxx	2090-CTFB-MADD-CFAxx (standard) or 2090-CTFB-MADD-CFFxx (continuous-flex)	-
TLP-A/B115-xxx, TLP-A/B145-xxx, TLP-A/B200-xxx, TLP-A/B235-xxx	2090-CTFB-MFDD-CFAxx (standard) or 2090-CTFB-MFDD-CFFxx (continuous-flex)	-
MPL-A/B15xxx-V/E, MPL-A/B2xxx-V/E, MPL-A/B3xxx-S/M, MPL-A/B4xxx-S/M, MPL-A/B45xxx-S/M, MPL-A/B5xxx-S/M, MPL-B6xxx-S/M, MPL-B8xxx-S/M, MPL-B9xxx-S/M		-
MPM-A/Bxxxx-S/M, MPF-A/Bxxxx-S/M, MPS-A/Bxxxx-S/M		-
MPAR-A/B1xxx-V and MPAR-A/B2xxx-V (series B) MPAR-A/B3xxx-M MPAI-A/BxxxxM3	2090-CFBM7DF-CEAxx (standard) or 2090-CFBM7DF-CEAFxx (continuous-flex)	-
MPAS-A/Bxxxx1-V05SxA (ballscrew) MPAS-A/Bxxxx2-V20SxA (ballscrew)		-
LDAT-Sxxxxx-xDx		-
MPL-A/B15xxx-H, MPL-A/B2xxx-H, MPL-A/B3xxx-H MPL-A/B4xxx-H, MPL-A/B45xxx-H	-	
MPAS-A/Bxxxx-ALMx2C (direct drive)	-	2090-XXNFMF-Sxx (standard) or 2090-CFBM7DF-CDAFxx (continuous-flex)
LDAT-Sxxxxx-xBx	-	
LDC-Cxxxxx-xH LDL-xxxxxx-xH	-	
TLY-Axxxx-B	2090-CFBM6DF-CBAAxx (standard) or 2090-CFBM6DD-CCAAxx (standard)	2090-CFBM6DF-CBAAxx (standard) or 2090-CFBM6DD-CCAAxx (standard)
TLY-Axxxx-H		
TL-Axxxx-B	2090-DANFCT-Sxx (standard)	-

(1) These are typical feedback cables. Refer to the Kinetix 5300 Servo Drives Design Guide, publication [KNX-RM012](#), for the cables required for specific drive and motor/actuator combinations.

### Kinetix 5300 Feedback Connector Kit Dimensions

Dimensions are in mm (in.).

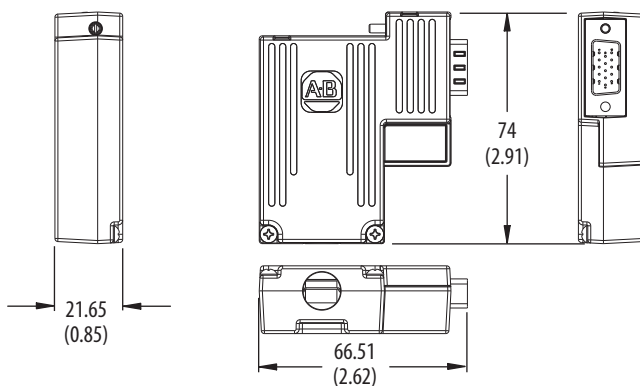



## Replacement Parts - Kinetix 5300 Servo Drives

Connector sets are included with each drive and these replacement sets are also available.

### Replacement Connector Sets

Replacement Kit Cat. No.	Description	Contents	Illustration
2198-CONKIT-PWR20	Replacement connector set for Frame 1 and Frame 2 servo drives, except 2198-C2030-ERS (Frame 2) drive.	<ul style="list-style-type: none"> <li>• One shunt connector <sup>(1)</sup></li> <li>• One AC input power connector</li> <li>• One control power connector</li> <li>• One motor power connector</li> <li>• One motor brake connector</li> <li>• One digital inputs and auxiliary feedback connector</li> <li>• One safe torque-off connector</li> <li>• One clamp spacer</li> </ul>	
2198-CONKIT-PWR30	Replacement connector set for 2198-C2030-ERS (Frame 2) servo drives.	<ul style="list-style-type: none"> <li>• One shunt connector <sup>(1)</sup></li> <li>• One AC input power connector</li> <li>• One control power connector</li> <li>• One motor power connector</li> <li>• One motor brake connector</li> <li>• One digital inputs and auxiliary feedback connector</li> <li>• One safe torque-off connector</li> <li>• One clamp spacer</li> </ul>	
2198-CONKIT-PWR75	Replacement connector set for 2198-C2055-ERS, 2198-C2075-ERS, 2198-C4055-ERS, 2198-C4075-ERS (Frame 3) servo drives.	<ul style="list-style-type: none"> <li>• One shunt connector <sup>(1)</sup></li> <li>• One AC input power connector</li> <li>• One control power connector</li> <li>• One motor power connector</li> <li>• One motor brake connector</li> <li>• One digital inputs and auxiliary feedback connector</li> <li>• One safe torque-off connector</li> <li>• One clamp spacer</li> <li>• One clamping plate</li> </ul>	

(1) This shunt connector plug is intended for use with an (optional) external shunt. Each 2198-Cxxxx-ERS drive also includes a shunt connector plug installed and wired to the internal shunt.

# Kinetix 5100 EtherNet/IP Indexing Servo Drives



Our Kinetix 5100 servo drives provide a scalable, cost-effective servo control choice in a single product line. With a wide power range (up to 15 kW) to choose from, Kinetix 5100 drives support applications controlled by stand-alone, Micro800™, MicroLogix™, and Logix 5000 controllers for a range of performance requirements. With Integrated Architecture™ capabilities in mind, the Kinetix 5100 drives can be readily integrated with specially built Add-On Instructions in Logix Designer applications. The drive comes with standard inputs and outputs, different modes of control, plus Safe Torque Off and dual-port EtherNet/IP for various network topologies. Designed for versatility, with the Kinetix 5100 drives you can select the power you need to fit the unique needs of the application.

## Kinetix 5100 Drive Features and Indicators

Features and Indicators (catalog numbers 2198-E1004-ERS, 2198-E1007-ERS, and 2198-E1015-ERS)

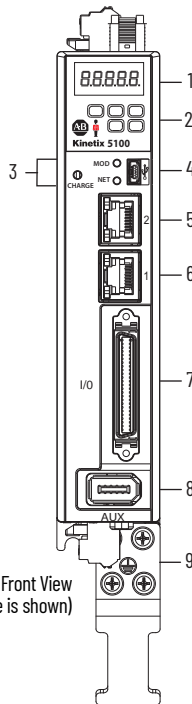

Kinetix 5100 Drive, Front View  
(2198-E1004-ERS drive is shown)

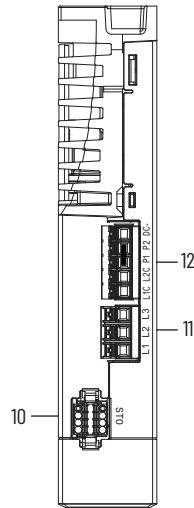

Kinetix 5100 Drive, Top View  
(2198-E1004-ERS drive is shown)

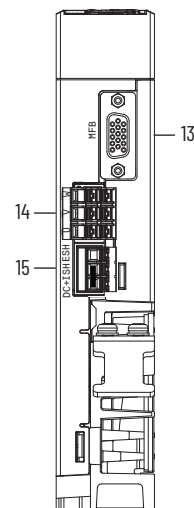

Kinetix 5100 Drive, Bottom View  
(2198-E1004-ERS drive is shown)

### Features and Indicators Description

Item	Description
1	Status display
2	Navigation push buttons
3	Module, Network, and Charge status indicators
4	Mini USB connector
5	Ethernet (PORT2) RJ45 connector
6	Ethernet (PORT1) RJ45 connector
7	I/O signal connector
8	Auxiliary feedback (AUX) connector

Item	Description
9	Motor cable ground plate
10	Safe torque-off (STO) connector
11	Mains input power connector
12	<ul style="list-style-type: none"> <li>Control power input (L1C and L2C) connections</li> <li>Reserved (P1, P2, and negative DC bus) not-used connections</li> </ul>
13	Motor feedback (MFB) connector
14	Motor power output terminals
15	Shunt resistor terminals

Features and Indicators (catalog numbers 2198-E1020-ERS, 2198-E2030-ERS, 2198-E4004-ERS, 2198-E4007-ERS, 2198-E4015-ERS)

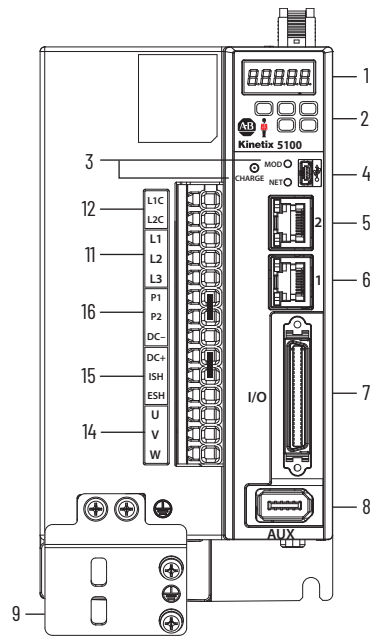

Kinetix 5100 Drive, Front View  
(2198-E1020-ERS drive is shown)

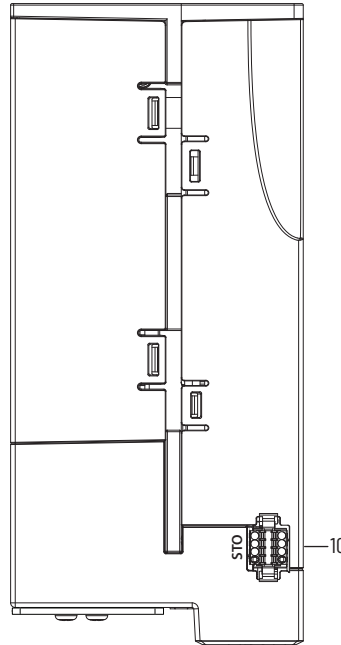

Kinetix 5100 Drive, Top View  
(2198-E1020-ERS drive is shown)

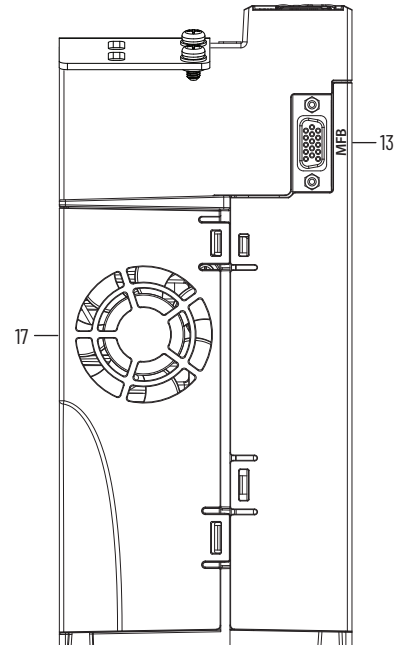

Kinetix 5100 Drive, Bottom View  
(2198-E1020-ERS drive is shown)

For feature descriptions see table on [page 112](#).

Features and Indicators (catalog numbers 2198-E4020-ERS, 2198-E4030-ERS)

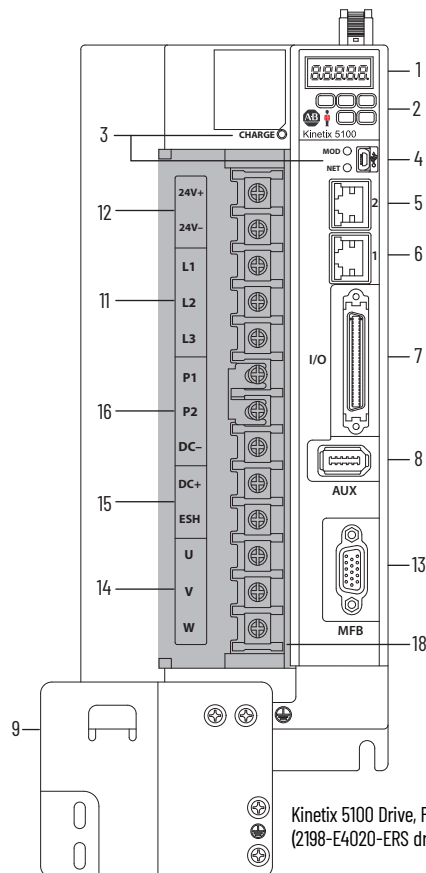

Kinetix 5100 Drive, Front View  
(2198-E4020-ERS drive is shown)

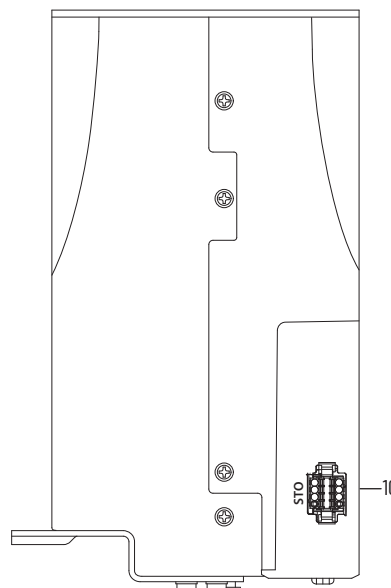

Kinetix 5100 Drive, Top View  
(2198-E4020-ERS drive is shown)

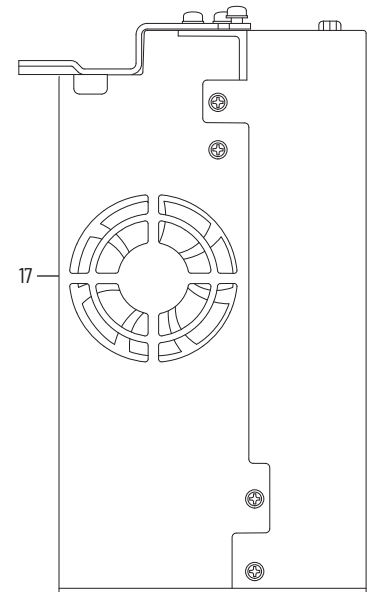

Kinetix 5100 Drive, Bottom View  
(2198-E4020-ERS drive is shown)

For feature descriptions see table on [page 112](#).

**Features and Indicators**

(catalog numbers 2198-E2055-ERS, 2198-E2075-ERS, 2198-E2150-ERS, 2198-E4055-ERS, 2198-E4075-ERS, and 2198-E4150-ERS)

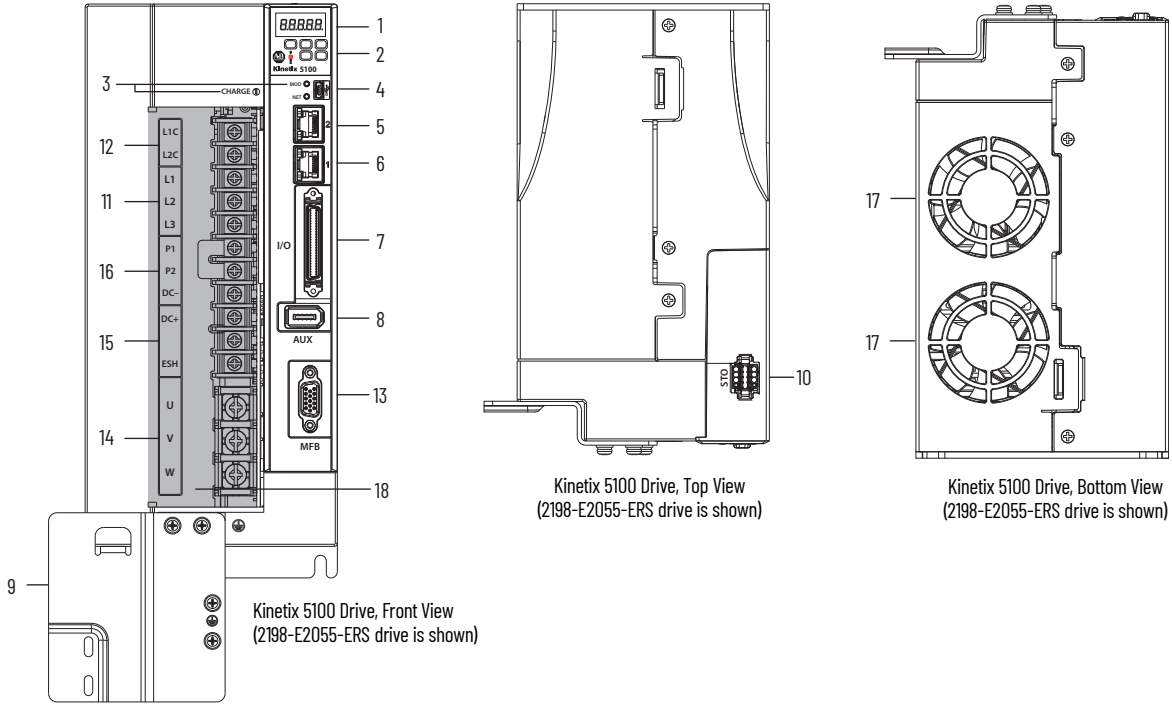

**Features and Indicators Description**

Item	Description
1	Status display
2	Navigation push buttons
3	Module, Network, and Charge status indicators
4	Mini USB connector
5	Ethernet (PORT2) RJ45 connector
6	Ethernet (PORT1) RJ45 connector
7	I/O signal connector
8	Auxiliary feedback (AUX) connector
9	Motor cable ground plate

Item	Description
10	Safe torque-off (STO) connector
11	Mains input power terminals
12	Control power input terminals <sup>(1)</sup>
13	Motor feedback (MFB) connector
14	Motor power output terminals
15	Shunt resistor terminals
16	Reserved (P1, P2, and negative DC bus) not-used connections
17	Cooling fans
18	Protective cover

(1) Control power terminals are labeled L1C/L2C for 2198-1xxx-ERS and 2198-2xxx-ERS (200V-class) drives and 24V+/24V- for 2198-4xxx-ERS (400V-class) drives.

## Technical Specifications - Kinetix 5100 Servo Drives

### Kinetix 5100 Power Specifications (single-phase and three-phase)

Attribute	2198-E1004-ERS	2198-E1007-ERS	2198-E1015-ERS	2198-E1020-ERS
AC input voltage	95...132V rms, single-phase (120V nom) 170...253V rms, single-phase (200...230V nom) 170...253V rms, three-phase (230V nom)			
AC input frequency	47...63 Hz			
Mains AC input current <sup>(1)</sup>				
Nom (rms) 120V input (single-phase)	4.08 A	7.88 A	12.22 A	18.40 A
Max inrush (0-pk) 120V input	0.84 A	0.76 A	0.76 A	2.56 A
Nom (rms) 230V input (single-phase)	4.79 A	8.85 A	14.41 A	21.36 A
Max inrush (0-pk) 230V input	1.40 A	1.32 A	1.36 A	4.40 A
Nom (rms) 230V input (three-phase)	2.84 A	5.20 A	7.87 A	11.57 A
Max inrush (0-pk) 230V input	1.44 A	1.40 A	1.44 A	4.64 A
Control power input voltage	95...132V rms, 120V AC nom, single-phase, with 120V AC input power 170...253V rms, 200...230V AC nom, single-phase, with 200...230V AC input power			
Control power input current <sup>(2)</sup>				
Nom (rms) 120V input	0.34 A	0.38 A	0.38 A	0.63 A
Max inrush (0-pk)	15.80 A	18.20 A	19.20 A	19.20 A
Nom (rms) 230V input	0.20 A	0.22 A	0.22 A	0.35 A
Max inrush (0-pk)	37.0 A	37.40 A	39.80 A	32.40 A
Continuous output current (rms)	2.6 A	5.1 A	7.9 A	13.4 A
Continuous output current (0-pk)	3.7 A	7.2 A	11.2 A	18.9 A
Peak output current (rms) <sup>(3)</sup>	6.5 A	15.41 A	23.7 A	40.58 A
Peak output current (0-pk)	9.2 A	21.8 A	33.5 A	57.4 A
Line loss ride through	20 ms			
Continuous output power				
@ 120V nom	0.20 kW	0.375 kW	0.75 kW	1.0 kW
@ 230V nom	0.40 kW	0.75 kW	1.50 kW	2.0 kW
Internal shunt on	370V @120V AC input			
Internal shunt off	370V @230V AC input			
Internal shunt resistor	100 Ω	100 Ω	100 Ω	20 Ω
Internal shunt power	5 W	14 W	14 W	20 W
Bus undervoltage	70V @120V AC input 150V @230V AC input			
Bus overvoltage	410V @120V AC input 410V @230V AC input			
Bus capacitance	540 μF	1680 μF	1680 μF	2160 μF
Capacitive energy absorption	9.6 J	29.9 J		38.4 J
Short-circuit current rating	5,000 A (rms) symmetrical			

(1) Kinetix 5100 drive modules are limited to 1 AC mains power cycling per minute.

(2) Kinetix 5100 drive modules are limited to 1 control power cycling every 20 seconds.

(3) Peak RMS current allowed for up to 1.8 seconds.

### Kinetix 5100 Power Specifications (230V nom three-phase)

Attribute	2198-E2030-ERS	2198-E2055-ERS	2198-E2075-ERS	2198-E2150-ERS
AC input voltage	170...253V rms, three-phase (230V nom)			
AC input frequency	47...63 Hz			
Mains AC input current <sup>(1)</sup>				
Nom (rms) 230V input (three-phase)	14.65 A	27.32 A	37.90 A	70.45 A
Max inrush (0-pk) 230V input	4.42 A	9.55 A	28.68 A	32.0 A
Control power input voltage	170...253V rms, 200...230V AC nom, single-phase, with 200...230V AC input power			
Control power input current <sup>(2)</sup>				
Nom (rms) 230V input	0.35 A	0.46 A	0.48 A	0.92 A
Max inrush (0-pk)	36.40 A	32.80 A	40.0 A	37.0 A
Continuous output current (rms)	17.9 A	41.3 A	49.0 A	78.0 A

Attribute	2198-E2030-ERS	2198-E2055-ERS	2198-E2075-ERS	2198-E2150-ERS
Continuous output current (0-pk)	25.3 A	58.4 A	69.3 A	110.3 A
Peak output current (rms) <sup>(3)</sup>	55.95 A	91.4 A	127.5 A	162.0 A
Peak output current (0-pk)	79.1 A	129.2 A	180.3 A	229.1 A
Line loss ride through	20 ms			
Continuous output power	3.0 kW	5.5 kW	7.5 kW	15.0 kW
Internal shunt on	370V			
Internal shunt off				
Internal shunt resistor	20 Ω	-	-	-
Internal shunt power	20 W	-	-	-
Bus undervoltage	150V			
Bus overvoltage	410V			
Bus capacitance	2160 μF	4100 μF	6000 μF	13,500 μF
Capacitive energy absorption	38.4 J	72.9 J	106.7 J	240.1 J
Short-circuit current rating	5,000 A (rms) symmetrical			

- (1) Kinetix 5100 drive modules are limited to 1 AC mains power cycling per minute.
- (2) Kinetix 5100 drive modules are limited to 1 control power cycling every 20 seconds.
- (3) Peak RMS current allowed for up to 1.8 seconds.

**Kinetix 5100 Power Specifications (480V nom three-phase)**

Attribute	2198-E4004-ERS	2198-E4007-ERS	2198-E4015-ERS	2198-E4020-ERS
AC input voltage	342...528V rms, three-phase (480V nom)			
AC input frequency	47...63 Hz			
Mains AC input current <sup>(1)</sup>				
Nom (rms) 380V input (three-phase)	1.49 A	2.31 A	5.009 A	6.29 A
Max inrush (0-pk) 380V input	5.66 A	5.66 A	5.66 A	9.43 A
Nom (rms) 480V input (three-phase)	1.34 A	2.08 A	4.38 A	4.94 A
Max inrush (0-pk) 480V input	7.15 A	7.15 A	7.15 A	11.91 A
Control power input voltage	21.6...26.4V DC 24V DC nom			
Control power input current @ 24V DC <sup>(2)</sup>	1.27 A <sub>DC</sub>			1.40 A <sub>DC</sub>
Control power in-rush current @ 24V DC	4.14 A <sub>DC</sub>			4.97 A <sub>DC</sub>
Continuous output current (rms)	1.60 A	3.19 A	6.05 A	7.42 A
Continuous output current (0-pk)	2.26 A	4.51 A	8.56A	10.49 A
Peak output current (rms) <sup>(3)</sup>	5.40 A	8.0 A	15.11 A	20.78 A
Peak output current (0-pk)	7.63 A	11.31 A	21.36 A	29.38 A
Line loss ride through	20 ms			
Continuous output power	0.40 kW	0.75 kW	1.50 kW	2.0 kW
Internal shunt on	760V			
Internal shunt off				
Internal shunt resistor	80 Ω			-
Internal shunt power	10 W			-
Bus undervoltage	282V			
Bus overvoltage	820V			
Bus capacitance	165 μF		235 μF	470 μF
Capacitive energy absorption	11.2 J		16.0 J	32.0 J
Short-circuit current rating	5,000 A (rms) symmetrical			

- (1) Kinetix 5100 drive modules are limited to 1 AC mains power cycling per minute.
- (2) Kinetix 5100 drive modules are limited to 1 control power cycling every 20 seconds.
- (3) Peak RMS current allowed for up to 1.8 seconds.

## Kinetix 5100 Power Specifications (480V nom three-phase, continued)

Attribute	2198-E4030-ERS	2198-E4055-ERS	2198-E4075-ERS	2198-E4150-ERS
AC input voltage	342...528V rms, three-phase (380/480V nom)			
AC input frequency	47...63 Hz			
Mains AC input current <sup>(1)</sup>				
Nom (rms) 380V input (three-phase)	9.96 A	16.825 A	23.664 A	36.855 A
Max inrush (0-pk) 380V input	9.43 A	9.43 A	9.43 A	28.28 A
Nom (rms) 480V input (three-phase)	7.91 A	13.35 A	18.78 A	29.25 A
Max inrush (0-pk) 480V input	11.91 A	11.91 A	11.91 A	35.73 A
Control power input voltage	21.6...26.4V DC, 24V DC nom			
Control power input current @ 24V DC <sup>(2)</sup>	1.77 A <sub>DC</sub>	2.03 A <sub>DC</sub>		4.43 A <sub>DC</sub>
Control power in-rush current @ 24V DC	4.97 A <sub>DC</sub>	3.24 A <sub>DC</sub>		3.40 A <sub>DC</sub>
Continuous output current (rms)	13.95 A	24.8 A	31.0 A	41.26 A
Continuous output current (0-pk)	19.73 A	35.07 A	43.84 A	58.35 A
Peak output current (rms) <sup>(3)</sup>	26.08 A	37.65 A	53.32 A	70.14 A
Peak output current (0-pk)	36.88 A	53.24 A	75.39 A	99.18 A
Line loss ride through	20 ms			
Continuous output power	3.0 kW	5.5 kW	7.5 kW	15.0 kW
Internal shunt on	760V			
Internal shunt off				
Internal shunt resistor	-	-	-	-
Internal shunt power	-	-	-	-
Bus undervoltage	282V			
Bus overvoltage	820V			
Bus capacitance	560 μF	1120 μF	1640 μF	2500 μF
Capacitive energy absorption	38.2 J	76.3 J	111.7 J	170.3 J
Short-circuit current rating	5,000 A (rms) symmetrical			

(1) Kinetix 5100 drive modules are limited to 1 AC mains power cycling per minute.

(2) Kinetix 5100 drive modules are limited to 1 control power cycling every 20 seconds.

(3) Peak RMS current allowed for up to 1.8 seconds.

## Circuit Breaker/Fuse Specifications

Kinetix 5100 servo drives use internal solid-state motor short-circuit protection and, when protected by suitable branch circuit protection, are rated for use on a circuit capable of delivering up to 5,000 A when protected by fuses or circuit breakers. These fuses and Allen-Bradley circuit breakers are recommended for use with 2198-Exxxx-ERS drives.

### Control Power Circuit-protection Specifications

Kinetix 5100 Drive Cat. No.	Fuse (Bussmann) Cat. No.	Circuit Breaker Cat. No.
2198-E1004-ERS	KTK-R-2 (2A)	1489-M2D010
2198-E1007-ERS		
2198-E1015-ERS		
2198-E1020-ERS		1489-M2D020
2198-E2030-ERS		1489-M2D010
2198-E2055-ERS	KTK-R-3 (3A)	1489-M2D016
2198-E2075-ERS		
2198-E2150-ERS	KTK-R-5 (5A)	1489-M2D030

### Input Power UL/CSA Circuit-protection Specifications

Kinetix 5100 Drive Cat. No.	Drive Voltage	Fuses (Bussmann) Cat. No.	Miniature Circuit Breaker Cat. No.	Molded Case Circuit Breaker Cat. No.
2198-E1004-ERS	120V/230V AC, single-phase	KTK-R-15 (15A)	1489-M2D100	-
	230V AC, three-phase	KTK-R-10 (10A)	1489-M3D100	-
2198-E1007-ERS	120/230V AC, single-phase	KTK-R-20 (20A)	1489-M2D200	-
	230V AC, three-phase	KTK-R-15 (15A)	1489-M3D130	-
2198-E1015-ERS	120/230V AC, single-phase	KTK-R-30 (30A)	1489-M2D300	-
	230V AC, three-phase	KTK-R-25 (25A)	1489-M3D200	-
2198-E1020-ERS	120/230V AC, single-phase	LPJ-40SP (40A)	1489-M2D400	-
	230V AC, three-phase	LPJ-35SP (35A)	1489-M3D300	-
2198-E2030-ERS	230V AC, three-phase	LPJ-50SP (50A)	1489-M3D350	-
2198-E2055-ERS		LPJ-70SP (70A)	1489-M3D600	-
2198-E2075-ERS		LPJ-80SP (80A)	-	140G-G2C3-C70
2198-E2150-ERS		LPJ-125SP (125A)	-	140G-G2C3-D12
2198-E4004-ERS		KTK-R-10 (10A)	1489-M3D100	-
2198-E4007-ERS	KTK-R-15 (15A)	1489-M3D100	-	
2198-E4015-ERS	KTK-R-20 (20A)	1489-M3D150	-	
2198-E4020-ERS	KTK-R-25 (25A)	1489-M3D200	-	
2198-E4030-ERS	KTK-R-30 (30A)	1489-M3D300	-	
2198-E4055-ERS	LPJ-35SP (35A)	1489-M3D350	-	
2198-E4075-ERS	LPJ-45SP (45A)	-	140G-G6C3-C45	
2198-E4150-ERS	LPJ-90SP (90A)	-	140G-G6C3-C60	

### Input Power IEC (non-UL/CSA) Circuit-protection Specifications

Kinetix 5100 Drive Cat. No.	Drive Voltage	DIN gG Fuses Amps, Max	Miniature Circuit Breaker Cat. No.	Molded Case Circuit Breaker Cat. No.
2198-E1004-ERS	120/230V AC, single-phase	15	1489-M2D100	-
	230V AC, three-phase	10	1489-M3D100	-
2198-E1007-ERS	120/230V AC, single-phase	20	1489-M2D200	-
	230V AC, three-phase	15	1489-M3D130	-
2198-E1015-ERS	120/230V AC, single-phase	30	1489-M2D300	-
	230V AC, three-phase	25	1489-M3D200	-



Kinetix 5100 Drive Cat. No.	Drive Voltage	DIN gG Fuses Amps, Max	Miniature Circuit Breaker Cat. No.	Molded Case Circuit Breaker Cat. No.
2198-E1020-ERS	120/230V AC, single-phase	40	1489-M2D400	-
	230V AC, three-phase	35	1489-M3D300	-
2198-E2030-ERS	230V AC, three-phase	50	1489-M3D350	-
2198-E2055-ERS		70	1489-M3D600	-
2198-E2075-ERS		80	-	140G-G2C3-C70
2198-E2150-ERS		125	-	140G-G2C3-D12
2198-E4004-ERS		10	1489-M3D100	-
2198-E4007-ERS	380...480V AC, three-phase	15	1489-M3D100	-
2198-E4015-ERS		20	1489-M3D150	-
2198-E4020-ERS		25	1489-M3D200	-
2198-E4030-ERS		30	1489-M3D300	-
2198-E4055-ERS		35	1489-M3D350	-
2198-E4075-ERS		45	-	140G-G6C3-C45
2198-E4150-ERS		90	-	140G-G6C3-C60

## Power Dissipation Specifications

Use this table to size an enclosure and calculate required ventilation for your Kinetix 5100 drive system.

Kinetix 5100 (200V) Drives Cat. No.	Loss, max W
2198-E1004-ERS	38.06
2198-E1007-ERS	66.33
2198-E1015-ERS	87.23
2198-E1020-ERS	139.83
2198-E2030-ERS	179.53
2198-E2055-ERS	328.52
2198-E2075-ERS	372.33
2198-E2150-ERS	648.55

Kinetix 5100 (400V) Drives Cat. No.	Loss (380V), max W	Loss (480V), max W
2198-E4004-ERS	51	56
2198-E4007-ERS	71	86
2198-E4015-ERS	99	117
2198-E4020-ERS	109	123
2198-E4030-ERS	214	220
2198-E4055-ERS	342	363
2198-E4075-ERS	467	494
2198-E4150-ERS	501	541

## Weight Specifications

Kinetix 5100 (200V-class) Drive Cat. No.	Weight, approx kg (lb)
2198-E1004-ERS	0.92 (2.0)
2198-E1007-ERS	1.30 (2.87)
2198-E1015-ERS	1.30 (2.87)
2198-E1020-ERS	2.70 (5.95)
2198-E2030-ERS	2.70 (5.95)
2198-E2055-ERS	5.0 (11.02)
2198-E2075-ERS	8.0 (17.62)
2198-E2150-ERS	15.0 (33.07)

Kinetix 5100 (400V-class) Drive Cat. No.	Weight, approx kg (lb)
2198-E4004-ERS	2.70 (5.95)
2198-E4007-ERS	
2198-E4015-ERS	
2198-E4020-ERS	4.50 (9.92)
2198-E4030-ERS	
2198-E4055-ERS	5.0 (11.02)
2198-E4075-ERS	10.0 (22.0)
2198-E4150-ERS	15.0 (33.07)

## Maximum Cable Lengths

Kinetix 5100 drive maximum cable length depends on the feedback type and input voltage that is used in the application. These tables assume the use of recommended cables as shown in the Kinetix Rotary and Linear Motion Cable Specifications Technical Data, publication [KNX-TD004](#).

### Maximum Cable Lengths (200V-Class) Motors

Compatible Motor and Actuator Cat. No.	Feedback Type <sup>(1)</sup>	Cable Length, max m (ft)
TLP-Axxx-xxx-D	Nikon (24-bit) absolute high-resolution, multi-turn and single-turn	50 (164)
MPL-A15xxx-V/Ex7xAA MPL-A2xxx-V/Ex7xAA	HiPerface, absolute high-resolution, multi-turn and single-turn	
MPL-A3xxx-S/Mx7xAA MPL-A4xxx-S/Mx7xAA MPL-A45xxx-S/Mx7xAA MPL-A5xxx-S/Mx7xAA		
MPM-Axxxx-S/M MPF-Axxxx-S/M MPS-Axxxx-S/M		
MPAR-A3xxxx-M		
MPAS-A/Bxxxx1-V05SxA (ballscrew) MPAS-A/Bxxxx2-V20SxA (ballscrew) MPAR-A/B1xxxx-V and MPAR-A/B2xxxx-V (series B) MPAI-A/BxxxxM3		
MPL-A15xxx-Hx7xAA MPL-A2xxx-Hx7xAA	Incremental	30 (98.4)
MPL-A3xxx-Hx7xAA MPL-A4xxx-Hx7xAA MPL-A45xxx-Hx7xAA		
MPAS-A/Bxxxx-ALMx2C (direct drive)		
TLY-Axxxx-B	Tamagawa (17-bit) absolute high-resolution, multi-turn	
TL-Axxxx-B		
TLY-Axxxx-H	Incremental	
LDAT-Sxxxxx-xBx	Incremental, magnetic scale	10 (33.1)
LDC-Cxxxxxx-xH, LDL-xxxxxx-xH	Sin/Cos or TTL encoder	

(1) For motors with incremental feedback, the maximum motor cable length is 30 m (98 ft).

## Maximum Cable Lengths (400V-Class) Motors

Compatible Motor and Actuator Cat. No.	Feedback Type	Cable Length, max m (ft)	
		≤ 400V AC Input	480V AC Input
TLP-B200-xxx-D	Nikon (24-bit) absolute high-resolution, multi-turn and single-turn	50 (164)	15 (49.2)
TLP-B070-xxx-D, TLP-B090-xxx-D, TLP-B115-xxx-D, TLP-B145-xxx-D, TLP-B235-xxx-D			50 (164)
MPL-B15xxx-V/Ex7xAA MPL-B2xxx-V/Ex7xAA		50 (164)	20 (65.6)
MPL-B3xxx-S/Mx7xAA MPL-B4xxx-S/Mx7xAA MPL-B45xxx-S/Mx7xAA MPL-B5xxx-S/Mx7xAA MPL-B6xxx-S/Mx7xAA MPL-B8xxx-S/Mx7xAA MPL-B9xxx-S/Mx7xAA	HiPerface, absolute high-resolution, multi-turn and single-turn	50 (164)	
MPM-Bxxxx-S/M MPF-Bxxxx-S/M MPS-Bxxxx-S/M			
MPAR-B3xxx-M			
MPAS-A/Bxxxx1-V05SxA (ballscrew) MPAS-A/Bxxxx2-V20SxA (ballscrew) MPAR-A/B1xxxx-V and MPAR-A/B2xxxx-V (series B) MPAI-A/BxxxxM3	Absolute high-resolution, multi-turn	50 (164)	20 (65.6)
MPL-B15xxx-Hx7xAA MPL-B2xxx-Hx7xAA	Incremental	30 (98.4)	20 (65.6)
MPL-B3xxx-Hx7xAA MPL-B4xxx-Hx7xAA MPL-B45xxx-Hx7xAA		30 (98.4)	
MPAS-A/Bxxxx-ALMx2C (direct drive)		Incremental, magnetic linear	
LDAT-Sxxxxx-xBx	Incremental, magnetic scale		
LDC-Cxxxxx-xH, LDL-xxxxxx-xH	Sin/Cos or TTL encoder	10 (33.1)	

## Dimensions - Kinetix 5100 Servo Drives

These drawings provide mounting dimensions for Kinetix 5100 servo drives. Mounting dimensions that include the feedback connector kit or drive-end cable connector are also shown.

Catalog Numbers 2198-E1004-ERS, 2198-E1007-ERS, and 2198-E1015-ERS

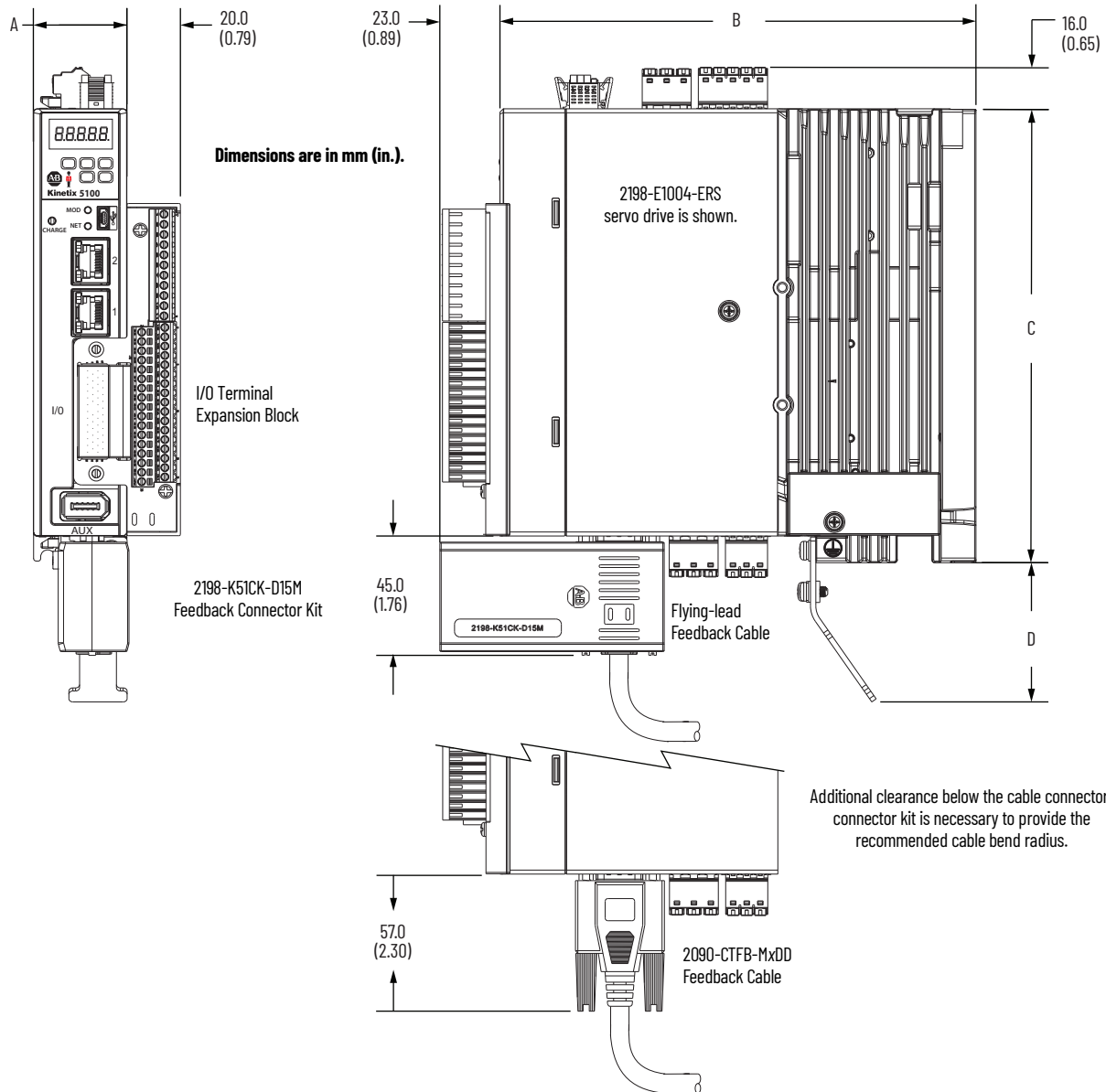

### Kinetix 5100 Drive Dimensions

Cat. No.	A mm (in.)	B mm (in.)	C mm (in.)	D mm (in.)
2198-E1004-ERS	35.0 (1.37)	178 (7.0)	170 (6.68)	52.0 (2.05)
2198-E1007-ERS	50.0 (2.0)	188 (7.41)	180 (7.10)	47.0 (1.84)
2198-E1015-ERS				

Catalog Numbers 2198-E1020-ERS, 2198-E2030-ERS, 2198-E4004-ERS, 2198-E4007-ERS, and 2198-E4015-ERS

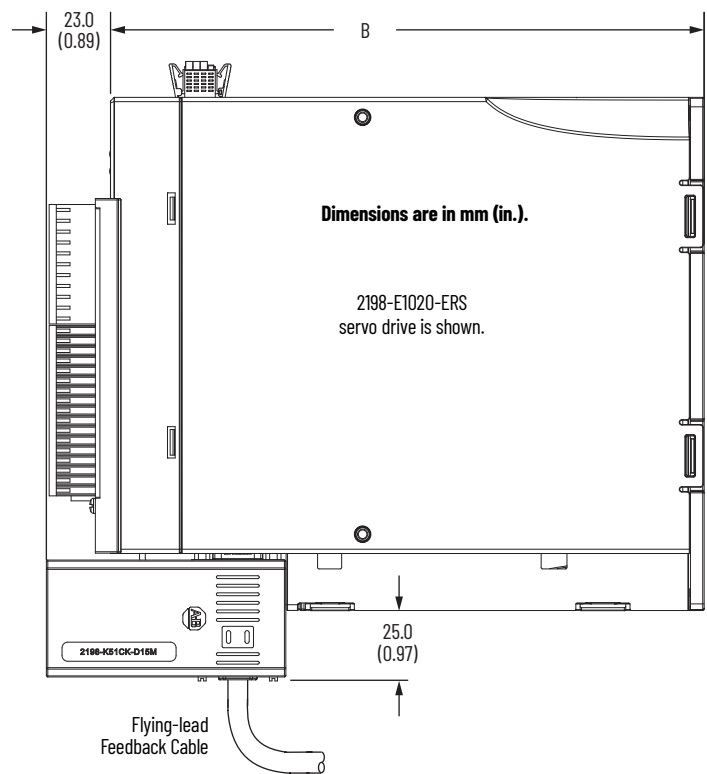
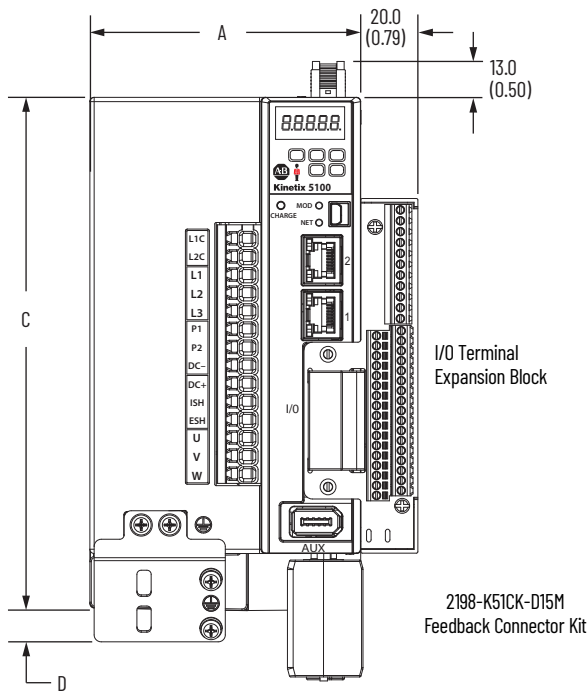

Additional clearance below the cable connector/connector kit is necessary to provide the recommended cable bend radius.

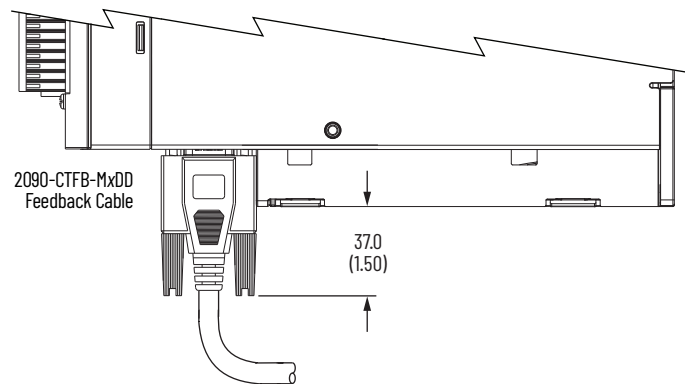

Kinetix 5100 Drive Dimensions

Cat. No.	A mm (in.)	B mm (in.)	C mm (in.)	D mm (in.)
2198-E1020-ERS	95.0 (3.74)	208 (8.20)	180 (7.09)	11.0 (0.43)
2198-E2030-ERS				
2198-E4004-ERS				
2198-E4007-ERS				
2198-E4015-ERS				

**Catalog Numbers**

2198-E4020-ERS, 2198-E4030-ERS, 2198-E2055-ERS, 2198-E4055-ERS, 2198-E2075-ERS, 2198-E4075-ERS, 2198-E2150-ERS, and 2198-E4150-ERS

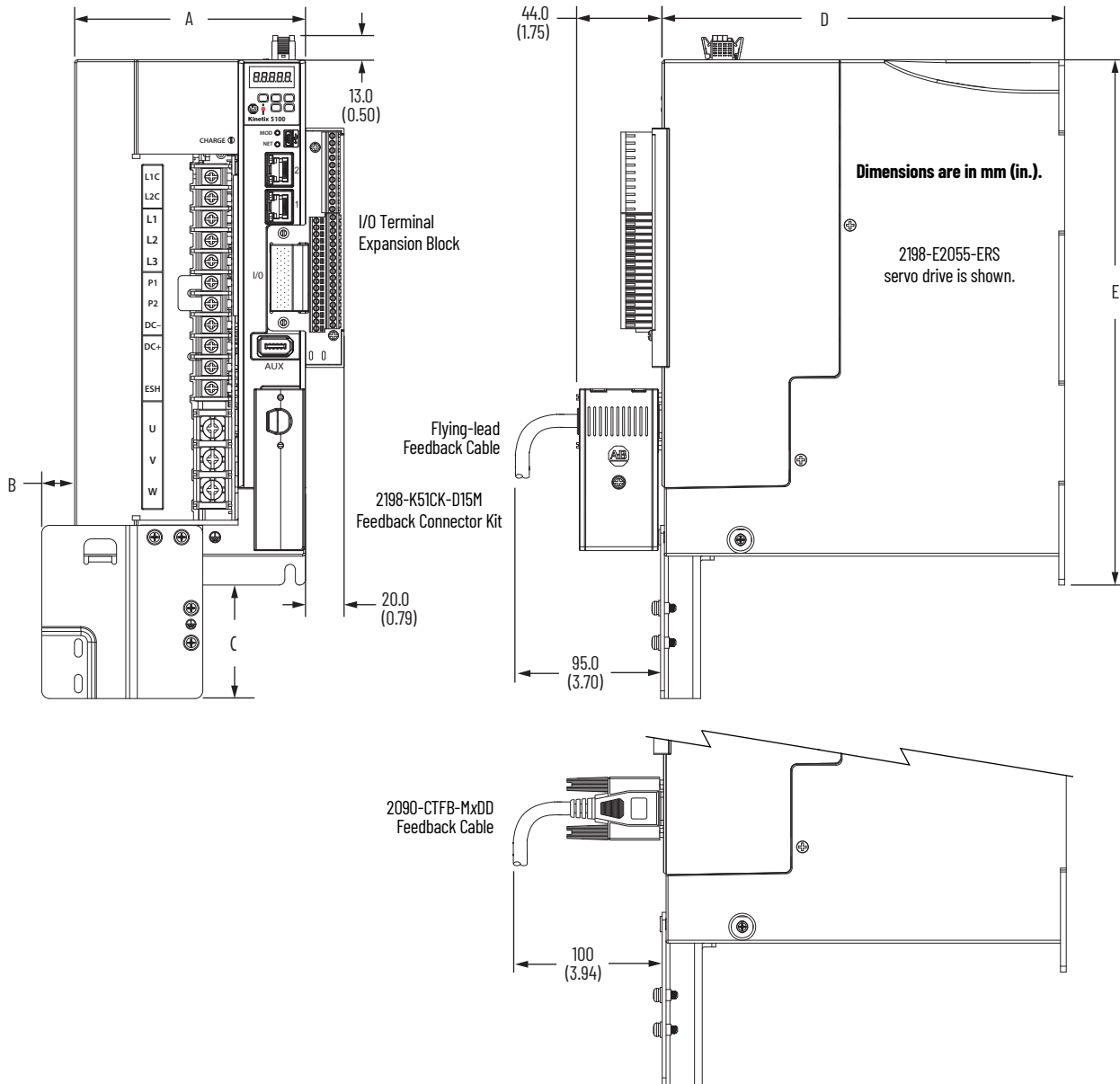

**Kinetix 5100 Drive Dimensions**

Cat. No.	A mm (in.)	B mm (in.)	C mm (in.)	D mm (in.)	E mm (in.)
2198-E4020-ERS	110 (4.33)	14.0 (0.55)	38.0 (1.50)	204 (8.02)	260 (10.24)
2198-E4030-ERS					
2198-E2055-ERS	120 (4.72)	37.0 (1.47)	59.0 (2.32)	209 (8.24)	273 (10.75)
2198-E4055-ERS					
2198-E2075-ERS	141 (5.55)	16.0 (0.65)	35.0 (1.36)	225 (8.87)	312 (12.28)
2198-E4075-ERS				281 (11.08)	
2198-E2150-ERS					
2198-E4150-ERS	186 (7.32)				390 (15.35)

## Environmental Specifications - Kinetix 5100 Servo Drives

Attribute	Operational Range	Storage Range (nonoperating)
Temperature, ambient	0...50 °C (32...122 °F)	-40...+70 °C (-40...158 °F)
Relative humidity	5...85% noncondensing	5...95% noncondensing
Altitude	1000 m (3281 ft)	1000 m (3281 ft)
Vibration	5...55 Hz @ 0.35mm (0.014in) double amplitude, continuous displacement; 55...500 Hz @ 2.0g peak constant acceleration (10 sweeps in each of 3 mutually perpendicular directions)	
Shock	15 g, 11 ms half-sine pulse (3 pulses in each direction of 3 mutually perpendicular directions)	

## Certifications - Kinetix 5100 Servo Drives

Agency Certification <sup>(1)</sup> (when product is marked)	Standards
cULus <sup>(2)</sup>	UL Listed to U.S. and Canadian safety standards (UL 61800-5-1 and CSA 22.2 No. 274, File E59272). Solid-state motor overload protection is provided when 110% of the motor rating is reached with a peak current limit based on the peak rating of the motor as investigated by UL to comply with UL 61800-5-1 (UL File E59272).
CE	European Union 2004/108/EC EMC Directive compliant with IEC 61800-3:2004 + A1:2012: Adjustable Speed Electrical Power Drive Systems - Part 3; EMC Product Standard including specific test methods. European Union 2006/95/EC Low Voltage Directive compliant with IEC 61800-5-1:2007 - Adjustable speed electrical power drive systems.
Functional Safety	TÜV certified for functional safety: up to Performance Level (PL) d, Category 3 according to ISO 13849; up to SIL CL2 according to IEC 61508, IEC 61800-5-2, and IEC 62061 when used as described in the Kinetix 5100 Single-axis EtherNet/IP Servo Drives User Manual, publication <a href="#">2198-UM004</a> .
RCM	Australian Radiocommunications Act, compliant with: <ul style="list-style-type: none"> <li>• Radiocommunications Act: 1992 (including Amendments up to 2017)</li> <li>• Radiocommunications (Electromagnetic Compatibility) Standard: 2017</li> <li>• Radiocommunications Labeling ((Compliance Labelling - Incidental Emissions) Notice: 2017</li> <li>• AS/NZS CISPR 11: 2002 (Group 1, Class A)</li> </ul>
KC	Korean Registration of Broadcasting and Communications Equipment, compliant with: <ul style="list-style-type: none"> <li>• Article 58-2 of Radio Waves Act, Clause 3</li> <li>• Registration number: KCC-REM-RAA-2198</li> </ul>
ODVA	EtherNet/IP conformance tested.
Ecodesign	IE2 efficiency class per Ecodesign regulation EU 2019/1781

(1) See [rok.auto/certifications](http://rok.auto/certifications) for declarations of conformity, certificates, and other certification details.

(2) UL has not evaluated the Safe Torque Off option in these products.

## Accessories - Kinetix 5100 Servo Drives

Kinetix 5100 drive accessories include the I/O terminal block, ground plates, passive shunt modules and resistors, AC line filters, a motor-feedback connector kit, and the feedback battery-box kit.

### I/O Terminal Expansion Block

The 2198-TBIO terminal expansion block is a drive-mounted breakout board for making flying-lead cable connections to the 50-pin I/O connector.

#### I/O Terminal Block Specifications

Attribute	Value
Wire size	1.5...0.05 mm <sup>2</sup> (16...30 AWG)
Change in depth of drive <sup>(1)</sup>	18 mm (0.70 in.)
Change in width of drive <sup>(1)</sup>	20 mm (0.79 in.)

(1) Add this value to the dimensions of your Kinetix 5100 drive.

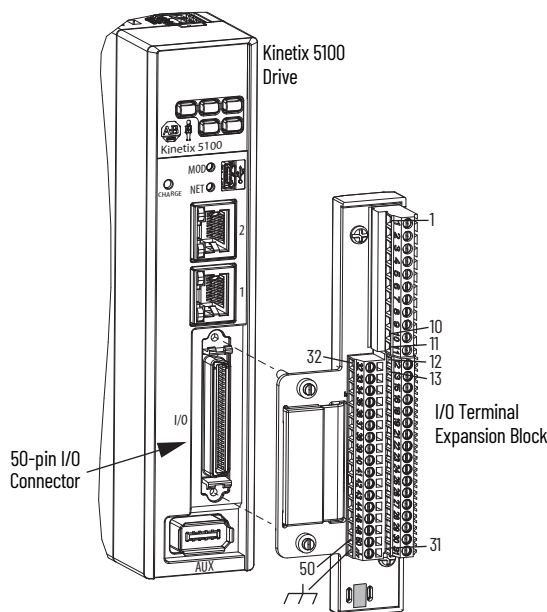

### Ground Plates

Ground plates are designed to provide a chassis ground connection for the motor-power cable shield and three-phase ground terminations. Each drive includes a ground plate and replacement ground plates are also available.

#### Ground Plate Catalog Numbers

Ground Plate Cat. No.	Kinetix 5100 (200V-class) Drives Cat. No.	Kinetix 5100 (400V-class) Drives Cat. No.
2198-GPFRM1	2198-E1004-ERS 2198-E1007-ERS 2198-E1015-ERS	-
2198-GPFRM3	2198-E1020-ERS 2198-E2030-ERS	2198-E4004-ERS 2198-E4007-ERS 2198-E4015-ERS
2198-GPFRM4	-	2198-E4020-ERS 2198-E4030-ERS
2198-GPFRM5	2198-E2055-ERS	2198-E4055-ERS
2198-GPFRM6	2198-E2075-ERS	2198-E4075-ERS
2198-GPFRM7	2198-E2150-ERS	2198-E4150-ERS



Ground Plate Dimensions

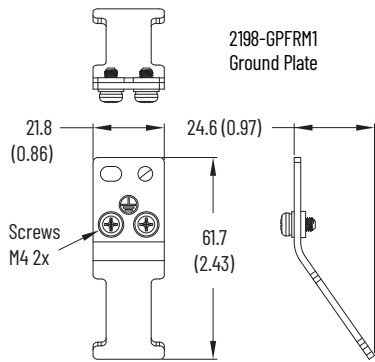

Dimensions are in mm (in.)

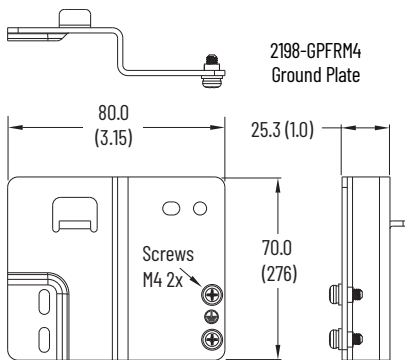
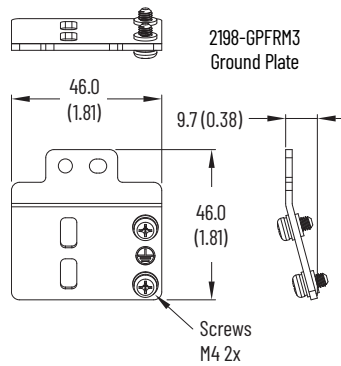

Dimensions are in mm (in.)

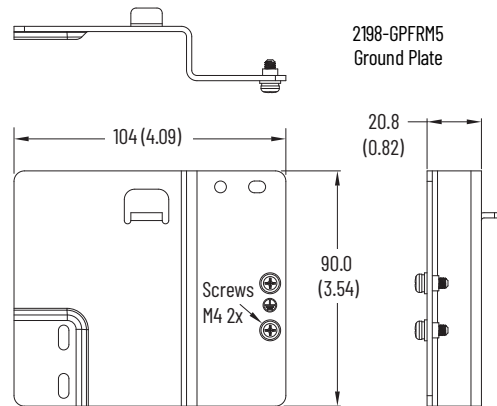

Dimensions are in mm (in.)

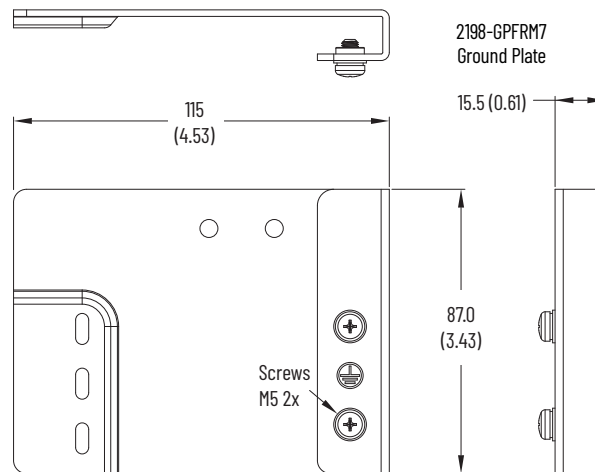
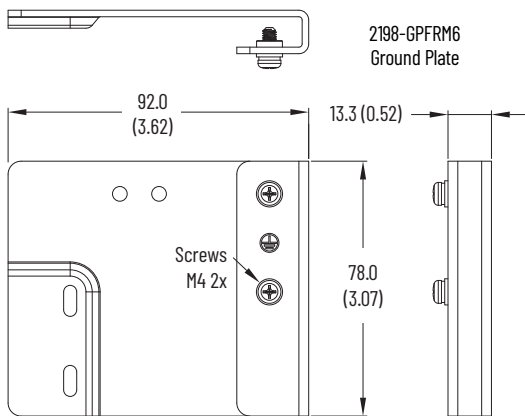

## Passive Shunt Modules and Resistors

The 2097-Rx and 2198-Rxxx external passive shunts are available to provide additional shunt capacity for applications where the internal shunt capacity is exceeded.

- Catalog number 2198-R031 is composed of resistor coils that are housed inside an enclosure.
- Catalog numbers 2198-R004, 2097-R6, and 2198-R7 are shunt resistors without an enclosure.

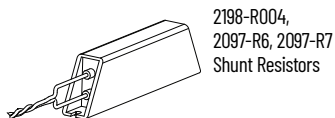
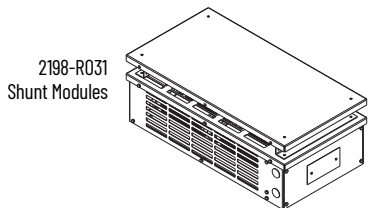

### Passive-shunt and Drive Compatibility

Drive Cat. No.	Internal Shunt Resistor	Shunt Power Capacity of Resistor	External Shunt Resistance, min	2198 External Shunt Module <sup>(1)</sup> Cat. No.		2097 External Shunt Module <sup>(1)</sup> Cat. No.	
	Ω	W	Ω	2198-R031	2198-R004	2097-R6	2097-R7
2198-E1004-ERS	100	5	60	-	-	X	X
2198-E1007-ERS		14	30	-	-	X	X
2198-E1015-ERS		14	30	X	X	X	X
2198-E1020-ERS	20	20	15	X	X	X	X
2198-E2030-ERS			15	X	X	X	X
2198-E2055-ERS	-	-	10	X	X	X	X
2198-E2075-ERS	-	-	10	X	X	X	X
2198-E2150-ERS	-	-	5	X	X	X	X
2198-E4004-ERS	80	10	80	-	-	-	X
2198-E4007-ERS			60	-	-	X	X
2198-E4015-ERS			40	-	-	X	X
2198-E4020-ERS	-	-	40	-	-	X	X
2198-E4030-ERS	-	-	30	X	X	X	X
2198-E4055-ERS	-	-	20	X	X	X	X
2198-E4075-ERS	-	-	15	X	X	X	X
2198-E4150-ERS	-	-	12	X	X	X	X

(1) Shunt resistor selection is based on the needs of your actual hardware configuration.

### Shunt Module Specifications

Shunt Module Cat. No.	Resistance Ohms	Continuous Power W	Weight, approx kg (lb)
2097-R6	75	150	0.3 (0.7)
2097-R7	150	80	0.2 (0.4)
2198-R004	33	400	1.8 (4.0)
2198-R031	33	3100	16.8 (37)

Refer to [Passive Shunt Modules and Resistors Dimensions on page 135](#) for product dimensions and additional specifications.

## Kinetix 5100 AC Line Filters

An AC line filter is required to meet CE requirements. Install the AC line filter as close to the drive as possible.

### AC Line Filter Selection

Kinetix 5100 Drive Cat. No.	Input Voltage (nom)	AC Line Filter Cat. No.		AC Line Filter Cat. No.
		Single-phase Operation		Three-phase Operation
2198-E1004-ERS	120V single-phase 200...230V single-phase 230V three-phase	2198-DB111-F	2198-DB310-F	2198-DB310-F
2198-E1007-ERS		2198-DB127-F		
2198-E1015-ERS			2198-DB324-F	
2198-E1020-ERS				
2198-E2030-ERS	230V three-phase	—	—	—
2198-E2055-ERS		—	2198-DB335-F	
2198-E2075-ERS		—	2198-DB356-F	
2198-E2150-ERS		—	2198-DBR90-F	
2198-E4004-ERS	480V three-phase	—	—	2198-DB418-F
2198-E4007-ERS		—	—	
2198-E4015-ERS		—	—	
2198-E4020-ERS		—	—	
2198-E4030-ERS		—	—	2198-DB433-F
2198-E4055-ERS		—	—	
2198-E4075-ERS		—	—	
2198-E4150-ERS		—	2198-DBR40-F	

**IMPORTANT** Select 2198-DB310-F and 2198-DB324-F line filters for replacements in existing installations and new systems of 2198-E10XX-ERS drives.

AC Line Filter Dimensions (catalog numbers 2198-DB111-F and 2198-DB310-F)

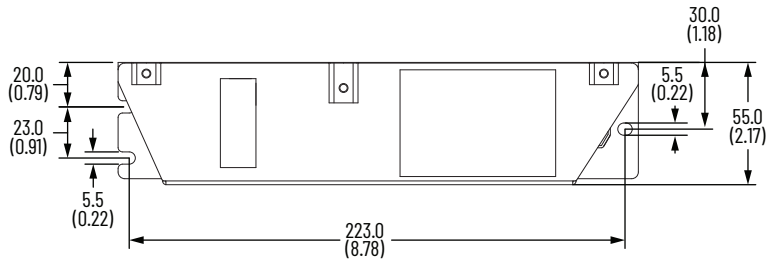

Dimensions are in mm (in.).

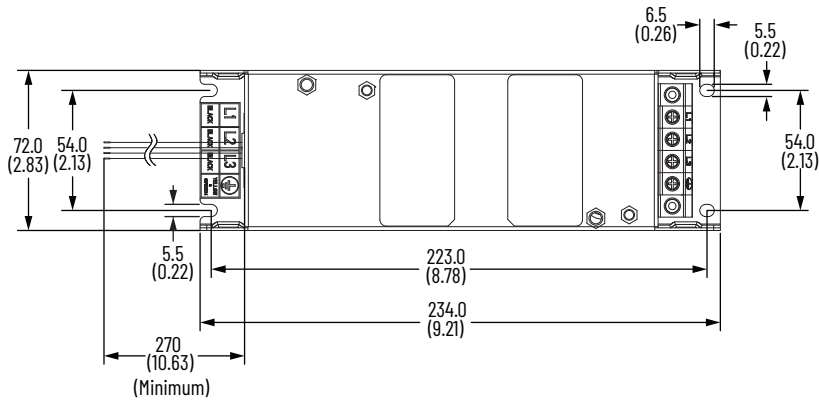

AC Line Filter Dimensions (catalog numbers 2198-DB127-F, 2198-DB324-F, and 2198-DB418-F)

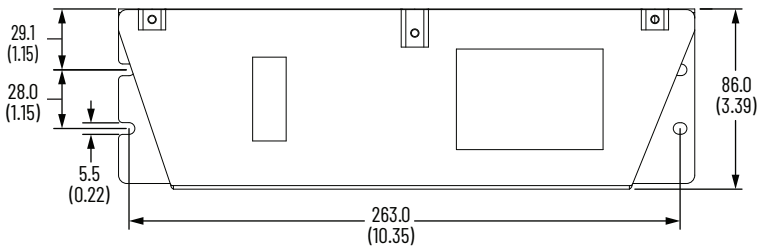

Dimensions are in mm (in.).

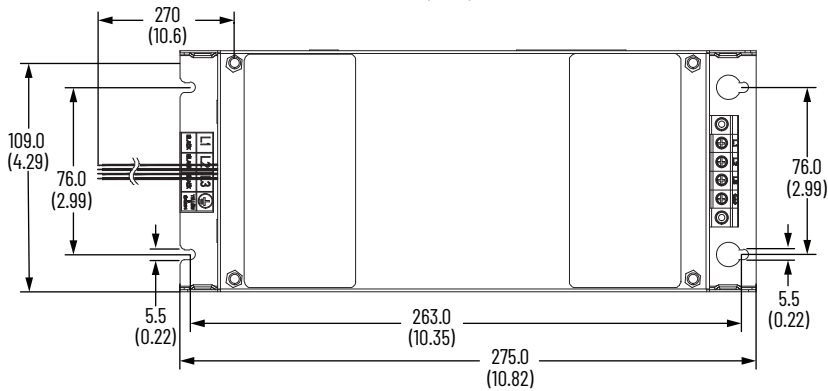

**AC Line Filter Dimensions (catalog number 2198-DB335-F and 2198-DB433-F)**

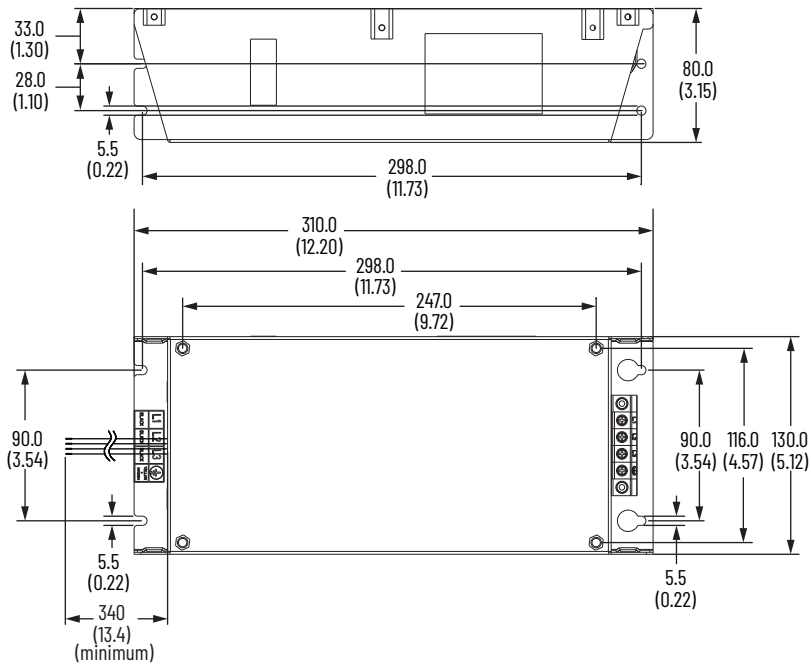

Dimensions are in mm (in.).

**AC Line Filter Dimensions (catalog number 2198-DB356-F)**

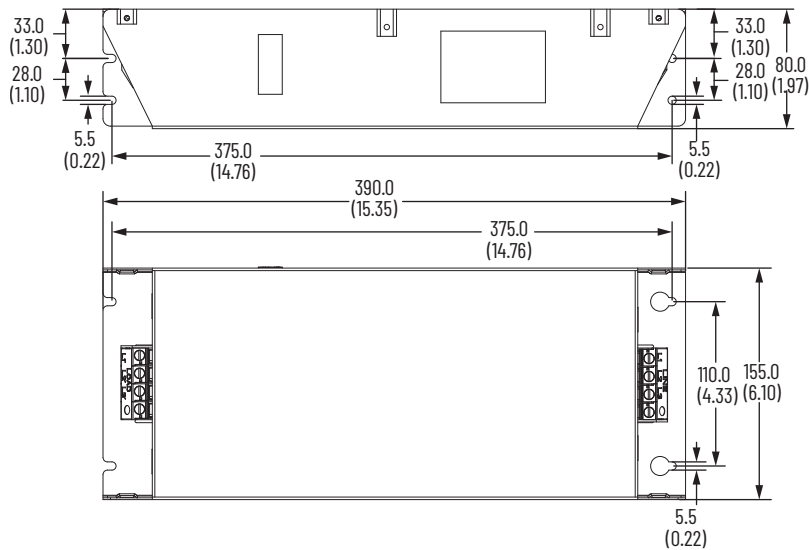

Dimensions are in mm (in.).

**AC Line Filter Dimensions (catalog number 2198-DBR40-F)**

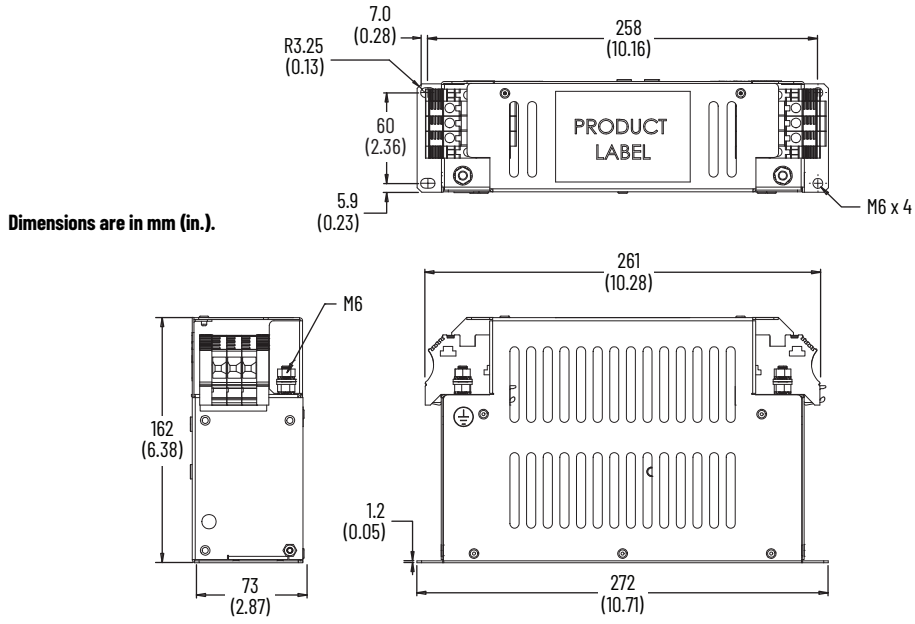

**AC Line Filter Dimensions (catalog number 2198-DBR90-F)**

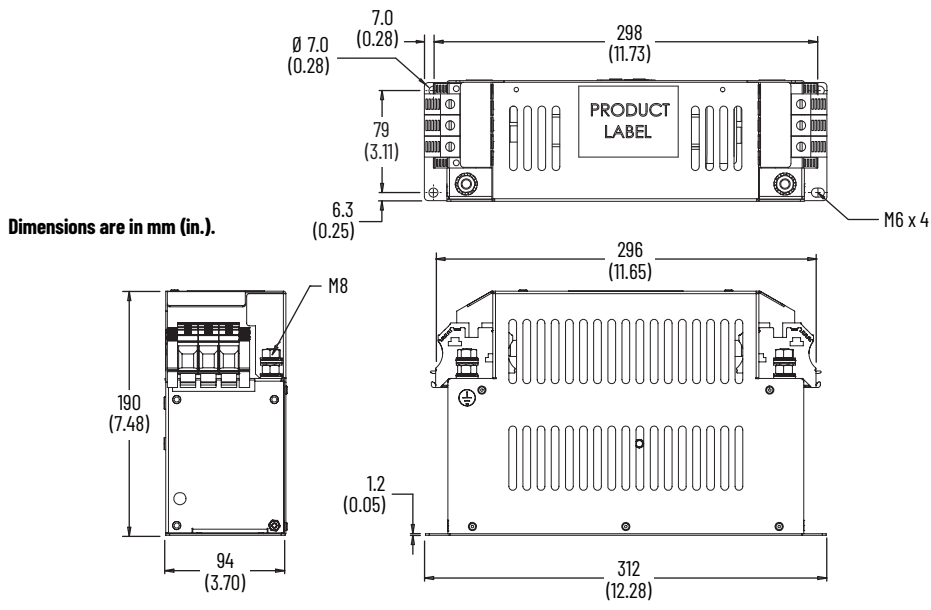

## AC Line Filter Specifications

Cat. No.	Voltage Rating <sup>(1)</sup>	Current Rating A @ 50 °C (122 °F)	Power Loss W	Leakage Current mA, typical	Weight, approx kg (lb)	Operating Temperature (Surrounding Air, max.)
2198-DB111-F	120V single-phase, 50/60 Hz	11	4.9	52.9	1.05 (2.314)	50 °C (122 °F)
2198-DB127-F	200...230V single-phase, 50/60 Hz	27	15.5	54.9	1.80 (3.968)	
2198-DB310-F	120V single-phase, 50/60 Hz	10	4.7	37.4	1.10 (2.425)	
2198-DB324-F	200...230V single-phase, 50/60 Hz	24	9.7	90	1.95 (3.968)	
2198-DB310-F	200...240V AC, three-phase, 50/60 Hz	10	14.0	3.9	1.10 (2.425)	
2198-DB324-F	200...240V AC, three-phase, 50/60 Hz	24	29.0	9.3	1.95 (3.968)	
2198-DB335-F	240V AC, three-phase, 48...63 Hz	34.8	30.0	5.8	2.90 (6.393)	
2198-DB356-F	240V AC, three-phase, 48...63 Hz	56	57.0	2.8	4.00 (8.818)	
2198-DB418-F	480V AC three-phase, 48...63 Hz	18.4	16.0	4.21	1.20 (2.65)	
2198-DB433-F	480V AC three-phase, 48...63 Hz	33	35.0	3.58	1.90 (4.19)	

(1) SCCR Rating of 5kA when used with UL branch circuit protection as listed in Kinetix 5100 EtherNet/IP Indexing Servo Drives, publication [2198-UM004](#).

## Kinetix 5100 Feedback Connector Kit

The 2198-K51CK-D15M feedback connector kit passes feedback signals from the encoder to the motor feedback (MFB) connector on the drive. The following encoder feedback types are accepted:

- Hiperface high-resolution absolute (multi-turn and single-turn)
- Nikon (24-bit) high-resolution serial encoder
- Tamagawa (17-bit) high-resolution serial encoder
- Digital AqB (TTL) and Digital AqB (TTL) with UVW incremental encoders

The 2198-K51CK-D15M feedback kit requires assembly with 2090-CFBM7DF or other customer-supplied cable. See Kinetix 5100 Feedback Connector Kit Installation Instructions, publication [2198-IN019](#), for more information.

Use the motor feedback connector kit in the following types of installations:

- New installations with Kinetix 5100 servo drives and compatible motors when flying-lead cable is used. For example, when building your own cables.
  - The 2198-K51CK-D15M feedback kit is not required when 2090-CTFB-MxDD feedback cable with premolded D-sub connector is used.
- Existing motor installations with flying-lead cable when upgrading with Kinetix 5100 servo drives.
- Any flying-lead feedback cable where battery backup is required for maintaining position data in the event of a power loss.
  - 3.6V 1/2 AA, ER14252 or equivalent battery
  - See [Feedback Battery Box Kit](#) on [page 133](#), for more battery specifications.

### Compatible Kinetix Motors and Actuators

Motors	Kinetix 2090 Feedback Cables <sup>(1)</sup>	
	High-resolution Encoder	Incremental Encoder
TLP-A046-xxx, TLP-A/B070-xxx, TLP-A/B090-xxx, TLP-A100-xxx	2090-CTFB-MADD-CFAxx (standard) or 2090-CTFB-MADD-CFFxx (continuous-flex)	-
TLP-A/B115-xxx, TLP-A/B145-xxx, TLP-A/B200-xxx, TLP-A/B235-xxx	2090-CTFB-MFDD-CFAxx (standard) or 2090-CTFB-MFDD-CFFxx (continuous-flex)	-
MPL-A/B15xxx-V/E, MPL-A/B2xxx-V/E, MPL-A/B3xxx-S/M, MPL-A/B4xxx-S/M, MPL-A/B45xxx-S/M, MPL-A/B5xxx-S/M, MPL-B6xxx-S/M, MPL-B8xxx-S/M, MPL-B9xxx-S/M		-
MPM-A/Bxxxx-S/M, MPF-A/Bxxxx-S/M, MPS-A/Bxxxx-S/M		-
MPAR-A/B1xxxx-V and MPAR-A/B2xxxx-V (series B) MPAR-A/B3xxxx-M MPAI-A/BxxxxM3	2090-CFBM7DF-CEAxx (standard) or 2090-CFBM7DF-CEAFxx (continuous-flex)	-
MPAS-A/Bxxxx1-V05SxA (ballscrew) MPAS-A/Bxxxx2-V20SxA (ballscrew)		-
LDAT-Sxxxxxx-xDx		-
MPL-A/B15xxx-H, MPL-A/B2xxx-H, MPL-A/B3xxx-H MPL-A/B4xxx-H, MPL-A/B45xxx-H	-	
MPAS-A/Bxxx-ALMx2C	-	2090-XXNFMF-Sxx (standard) or 2090-CFBM7DF-CDAFxx (continuous-flex)
LDAT-Sxxxxxx-xBx	-	
LDC-Cxxxxxx-xH LDL-xxxxxx-xH	-	
TLY-Axxxx-B	2090-CFBM6DF-CBAAxx (standard) or 2090-CFBM6DD-CCAAxx (standard)	2090-CFBM6DF-CBAAxx (standard) or 2090-CFBM6DD-CCAAxx (standard)
TLY-Axxxx-H		
TL-Axxxx-B	2090-DANFCT-Sxx (standard)	-

(1) These are typical feedback cables. Refer to the Kinetix 5100 Servo Drives Design Guide, publication [KNX-RM011](#), for the cables required for specific drive and motor/actuator combinations.



## Motor Feedback Connector Kit Dimensions

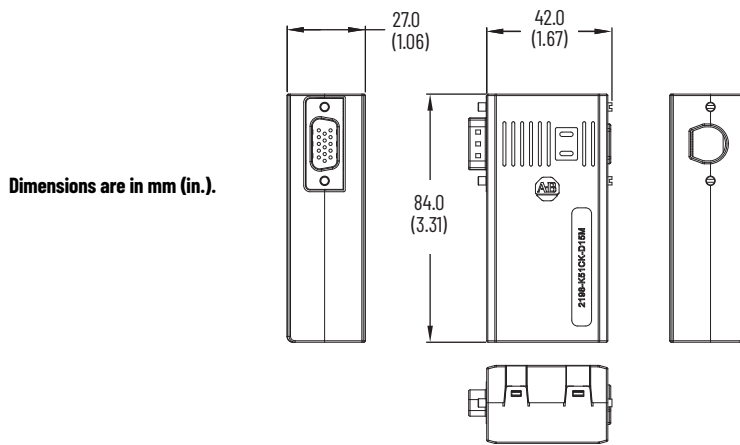

## Kinetix 5100 Auxiliary Feedback Connector Kit

The 2198-AUXKIT auxiliary feedback kit passes encoder signals to the auxiliary feedback (AUX) connector. Digital AqB (TTL) without UVW encoder feedback is accepted.

- Master feedback
- Load feedback

The 2198-AUXKIT auxiliary feedback kit requires assembly with customer-supplied cable. See Kinetix 5100 Auxiliary Feedback Connector Kit Installation Instructions, publication [2198-IN018](#), for more information.

## Feedback Battery Box Kit

The 2198-KTBT feedback battery-box kit (with user-supplied battery) is used with Kinetix TLP motors when multi-turn positioning is required. The 2090-CTFB-MxDD cables include this battery box and the 2198-KTBT battery box kit is available as a replacement. The battery box (with user-supplied battery) retains the multi-turn position over a power cycle.

See [Feedback Battery Box Kit on page 145](#) for product specifications and dimensions.

## Kinetix 5100 USB Interface Cable and Filter

Use the 2198-USBC mini-USB interface cable and 2198-USBF filter to provide the USB connection between your PC (KNX5100C drive configuration software) and drive. The USB filter provides a high-voltage isolation barrier between your PC and the drive.

### USB Filter Dimensions

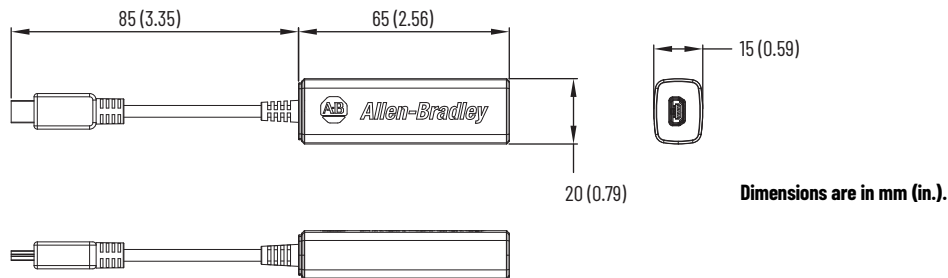

## Replacement Parts and Connector Kits - Kinetix 5100 Servo Drives

Replacement parts available for Kinetix 5100 servo drives include two drive connector-set kits.

Replacement Kit Cat. No.	Description	Drive Cat. No.	Illustration
2198-CONKIT-PKG	<ul style="list-style-type: none"> <li>• One mains input power connector</li> <li>• One control input power connector</li> <li>• One motor power connector</li> <li>• One shunt connector</li> <li>• One safe torque-off (STO) connector</li> <li>• One wire insertion tool</li> </ul>	2198-E1004-ERS <sup>(1)</sup> 2198-E1007-ERS 2198-E1015-ERS	
2198-CONKIT-STO	One safe torque-off (STO) connector	2198-E1020-ERS 2198-E2030-ERS 2198-E2055-ERS 2198-E2075-ERS 2198-E2150-ERS	

(1) If all that is needed for these catalog numbers is the STO connector, order 2198-CONKIT-STO.

# Common Accessories

These accessories are shared across the Kinetix 5700, 5500, 5300, and 5100 drive platforms.

## Passive Shunt Modules and Resistors Dimensions

### Shunt Module Dimensions (catalog numbers 2198-R014, 2198-R031, and 2198-R127)

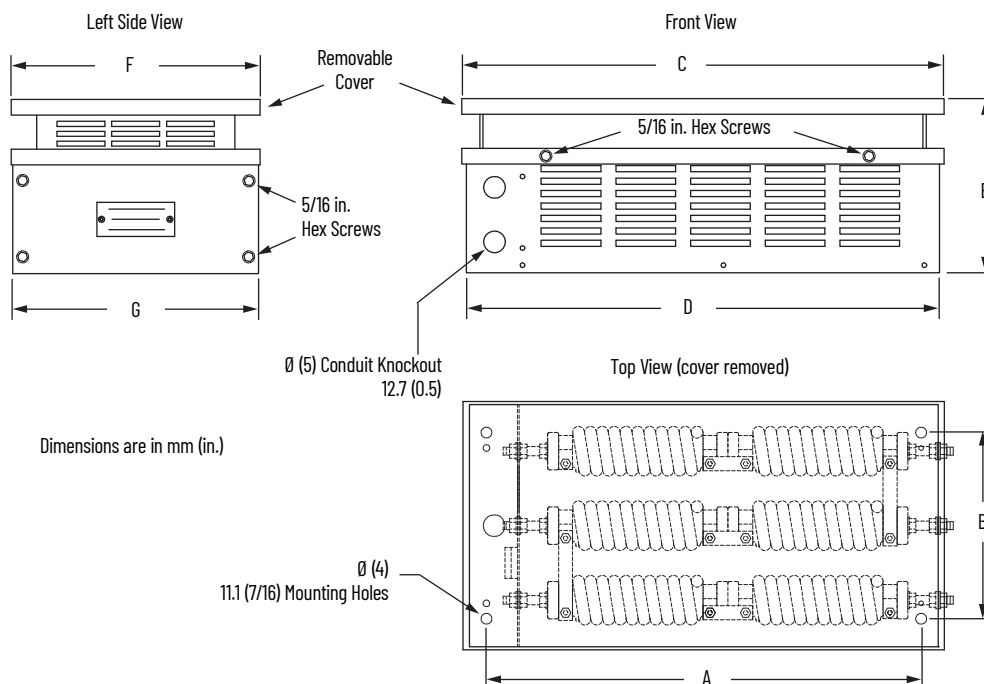

Shunt Module Cat. No.	A	B	C	D	E	F	G
2198-R014	445 (17.5)	191 (7.5)	492 (19.38)	483 (19.0)	178 (7.0)	254 (10.0)	251 (9.88)
2198-R031	635 (25.0)	343 (13.5)	683 (26.88)	673 (26.5)		406 (16.0)	403 (15.88)
2198-R127	673 (26.5)	267 (10.5)	721 (28.38)	711 (28.0)	305 (12.0)	330 (13.0)	327 (12.88)

### Shunt Resistor Dimensions (catalog number 2198-R004)

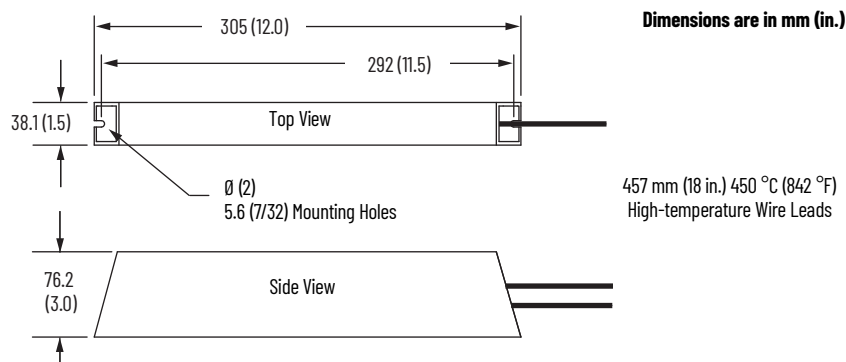

2097 Shunt Resistor Dimensions

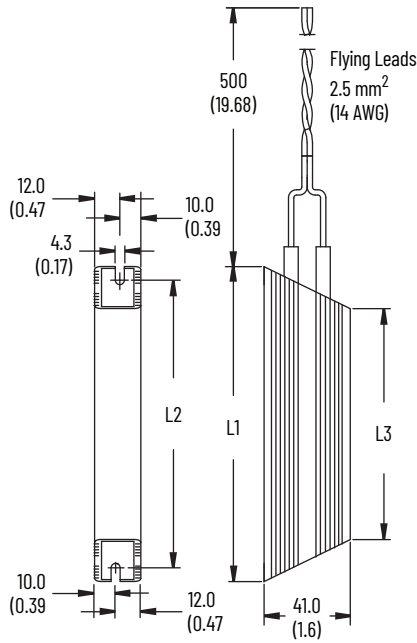

Dimensions are in mm (in.)

Shunt Resistor Cat. No.	L1	L2	L3
2097-R2	210 (8.3)	197 (7.7)	170 (6.7)
2097-R3	210 (8.3)	197 (7.7)	170 (6.7)
2097-R4	150 (5.9)	137 (5.4)	110 (4.3)
2097-R6	210 (8.3)	197 (7.7)	170 (6.7)
2097-R7	150 (5.9)	137 (5.4)	110 (4.3)

2097 Shunt Resistor Power Specifications

Shunt Module Cat. No.	Resistance Ohms	Continuous Power W	Peak Power kW	Peak Current A	D_Application, max <sup>(1)</sup> %	Weight kg (lb)
2097-R6	75	150	7.9	10.3	1.90	0.3 (0.7)
2097-R7	150	80	4.0	5.1	2.02	0.2 (0.4)

(1) D\_Application is the application duty cycle in percent. For the intermittent regeneration applications, use D\_Application = t/T, where t is the duration when regeneration is needed and T is the time interval between two regenerations. Both t and T must use the same time units, for example, seconds.

# Encoder Output Module

## Module Features and Indicators

2198-AB0E Encoder Output Module, Side View

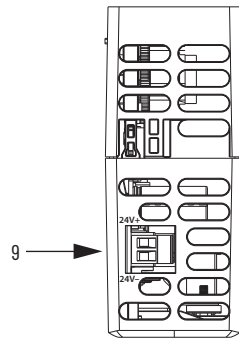
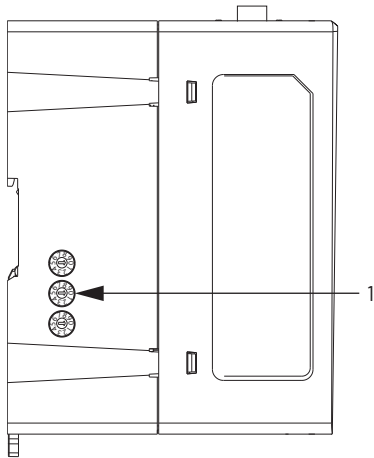

2198-AB0E Encoder Output Module, Top View

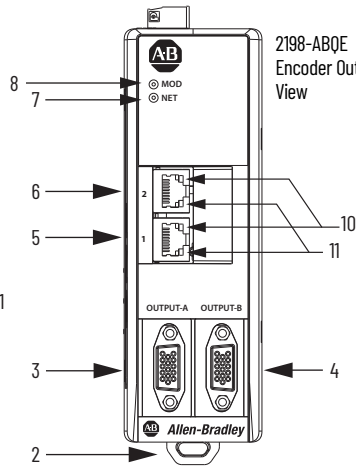

2198-AB0E Encoder Output Module, Front View

Item	Description
1	IP address switches
2	Mounting latch
3	15-pin output connector - A
4	15-pin output connector - B
5	Ethernet (PORT1) RJ45 connector
6	Ethernet (PORT2) RJ45 connector
7	Network status indicator
8	Module status indicator
9	24V control input power (CP) connector
10	Link speed status indicators
11	Link/Activity status indicators

## Encoder Output Module Dimensions

Dimensions are in mm (in.)

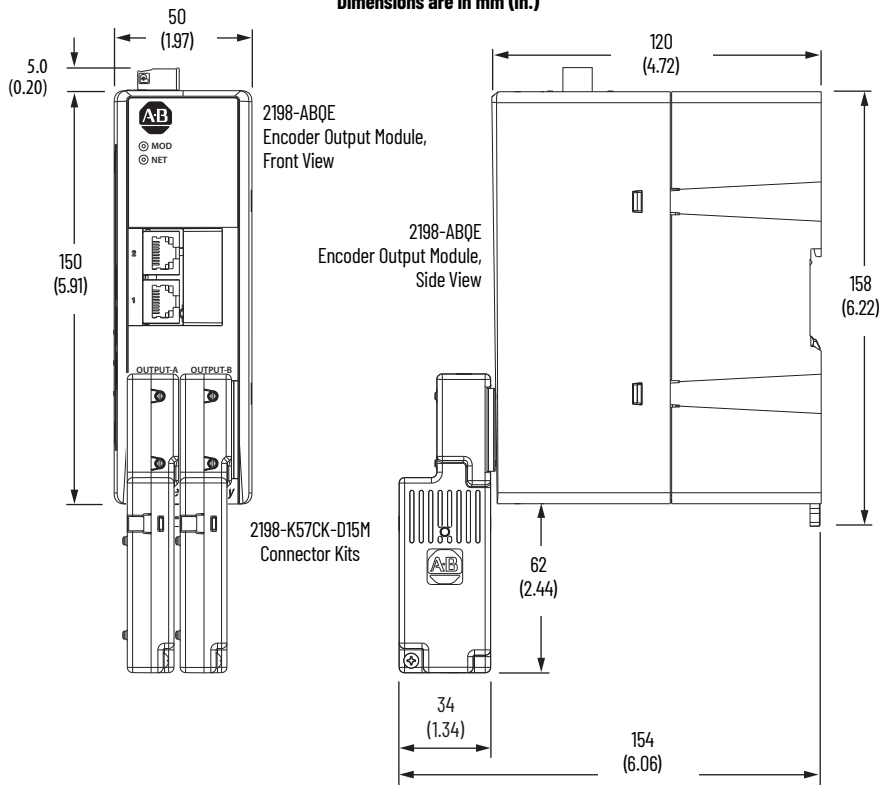

Included in the dimensions are 2198-K57CK-D15M connector kits attached to the output connectors. End anchors, used to secure the module on the DIN rail, add 8 mm (0.31 in.) on either side of the module.

**Encoder Output Module General Specifications**

Attribute	Value
Control input power (24V) ratings (SELV and LIM or Class 2 power supply)	21.6...26.4V DC (24 V DC, nom) 0.3 A, 7.2 W, max @ 24V DC
Control (input power) inrush current, max	3 A
Control input power connector wire size	16...24 AWG
Output power rating for single-ended outputs only (SELV and LIM or Class 2 power supply)	12...30V DC 0.14 A, max
Output connector wire size	16...28 AWG
Output signal type	Differential (RS422) or single-ended
Weight	0.50 kg (1.1 lb)

**AC Line Filter Dimensions and Specifications**

**AC Line Filter Selection**

DC-bus Power Supply Cat. No.	AC Line Filter (1) Cat. No.
2198-P031	<ul style="list-style-type: none"> <li>2198-DBR20-F or</li> <li>2198-DB20-F</li> </ul>
2198-P070	<ul style="list-style-type: none"> <li>2198-DBR40-F or</li> <li>2198-DB42-F</li> </ul>
2198-P141 2198-P208	<ul style="list-style-type: none"> <li>2198-DBR90-F or</li> <li>2198-DB80-F</li> </ul>
2198-P208 (2 in parallel) 2198-P208 (3 in parallel)	<ul style="list-style-type: none"> <li>2198-DBR200-F or</li> <li>2198-DB290-F</li> </ul>

Regenerative Bus Supply Cat. No.	AC Line Filter Cat. No.
2198-RP088	2198-DBR40-F
2198-RP200	2198-DBR90-F
2198-RP263 2198-RP312	2198-DBR200-F

(1) The use of 2198-DBRxx-F line filters provide a maximum total motor-power cable length of up to 1200 m (3937 ft). Maximum total motor-power cable length with 2198-DBxx-F line filters is 400 m (1312 ft). See the Kinetix 5700 Servo Drives User Manual, publication [2198-UM002](#) for more information on maximum cable lengths and how the use of 2198-DBRxx-F line filters affect ground screw/jumper settings.

**AC Line Filter Dimensions (catalog number 2198-DBR20-F)**

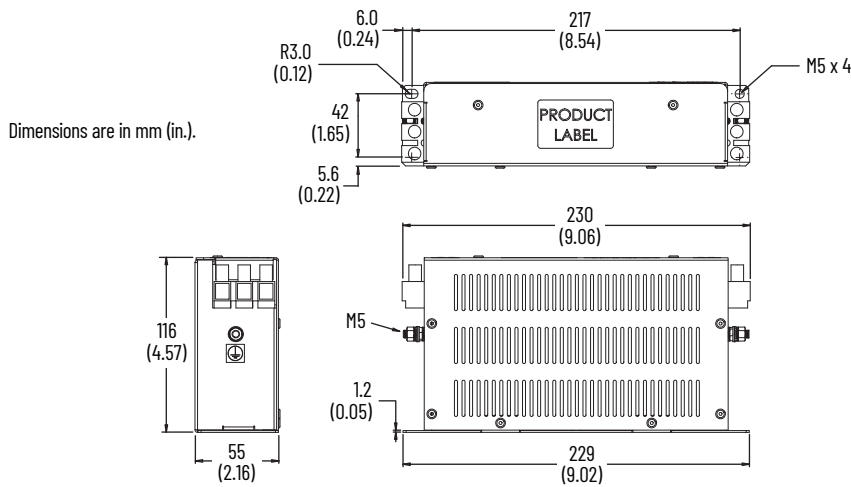

AC Line Filter Dimensions (catalog number 2198-DBR40-F)

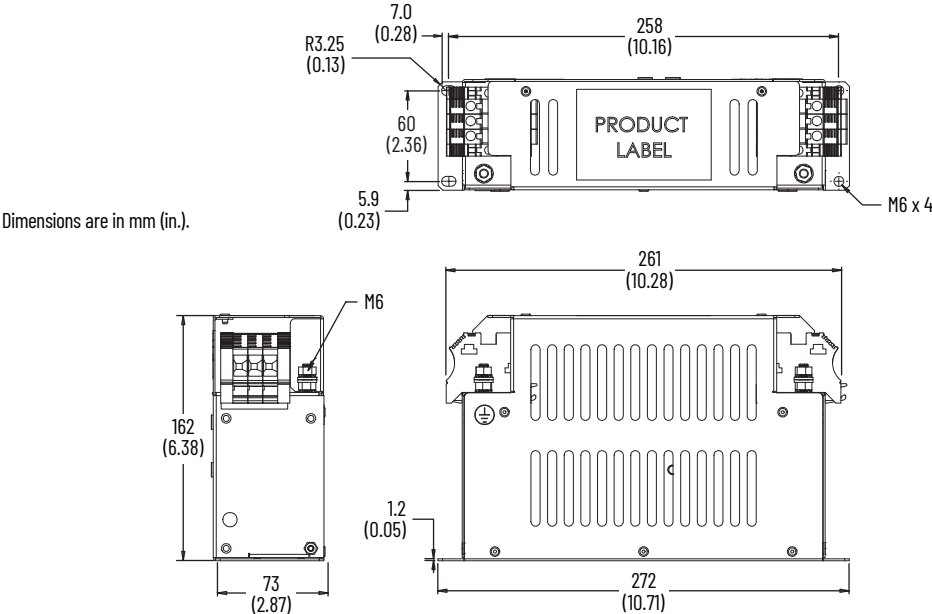

AC Line Filter Dimensions (catalog number 2198-DBR90-F)

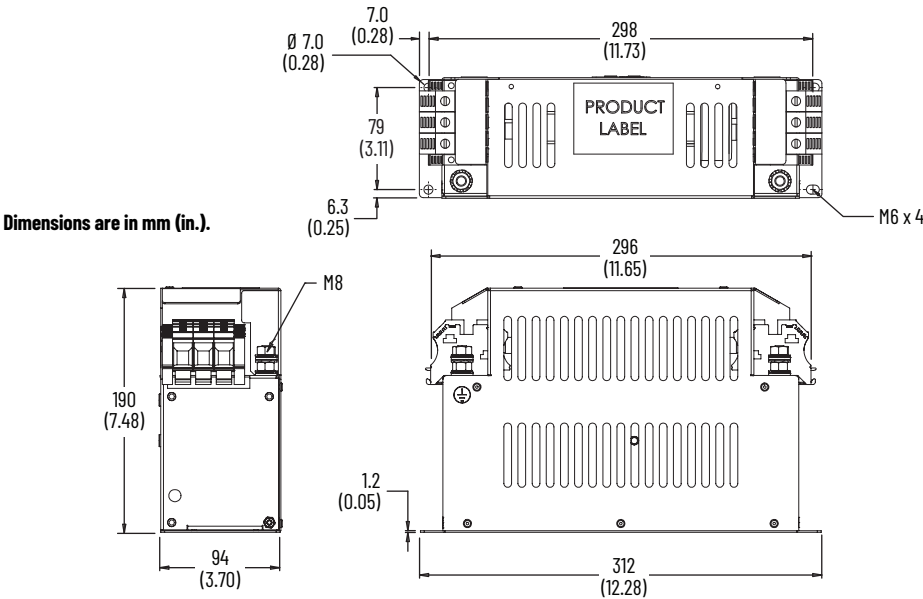

AC Line Filter Dimensions (catalog number 2198-DBR200-F)

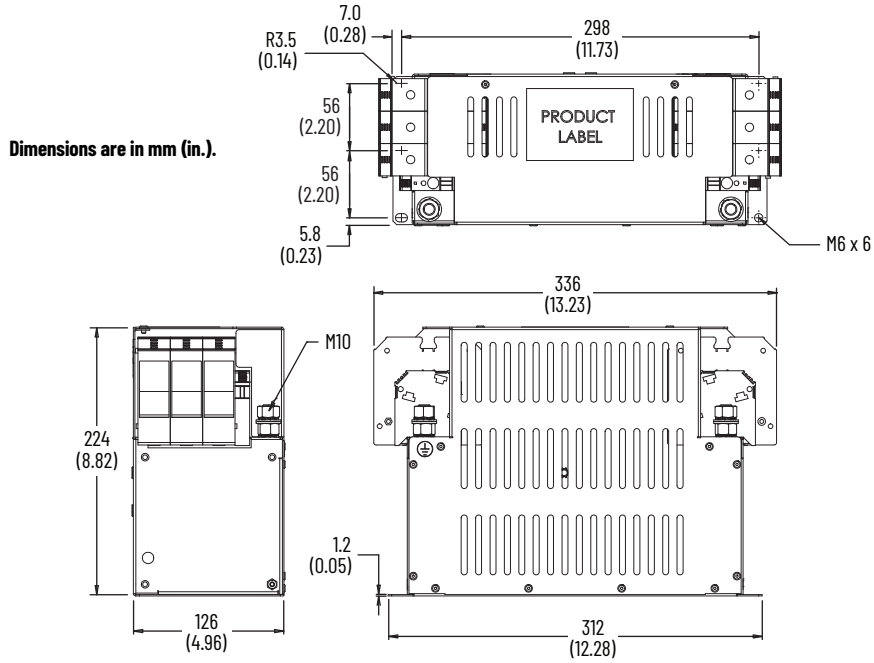

2198-DBRxx-F AC Line Filter Specifications

AC Line Filter Cat. No.	Voltage Rating, max	Current Rating A @ 50 °C (122 °F)	Power Loss W	Leakage Current mA	Weight, approx kg (lb)	Operating Temperature
2198-DBR20-F	528V AC three-phase 50/60 Hz	20	4.2	30.0	1.0 (2.20)	0...50 °C (32...122 °F)
2198-DBR40-F		54	15.0		3.3 (7.28)	
2198-DBR90-F		90	16.8		4.1 (9.04)	
2198-DBR200-F		200	34.5		7.2 (15.87)	



AC Line Filter Dimensions (catalog number 2198-DB08-F)

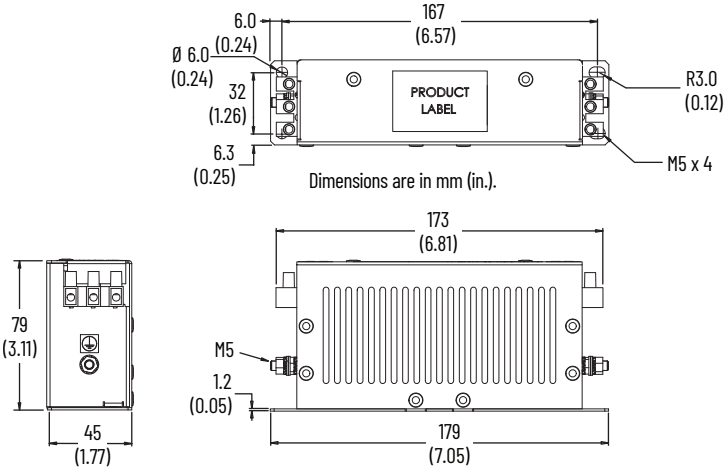

AC Line Filter Dimensions (catalog number 2198-DB20-F)

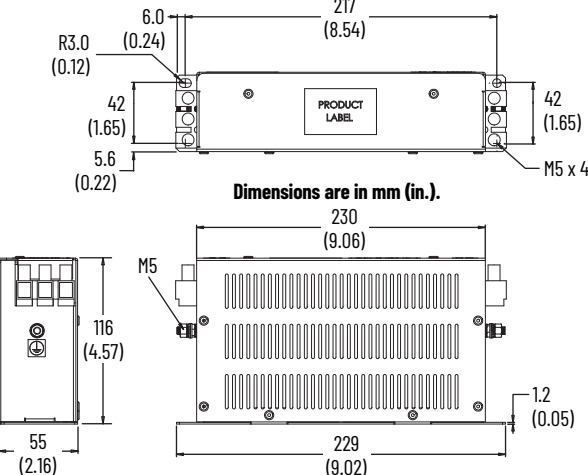

AC Line Filter Dimensions (catalog number 2198-DB42-F)

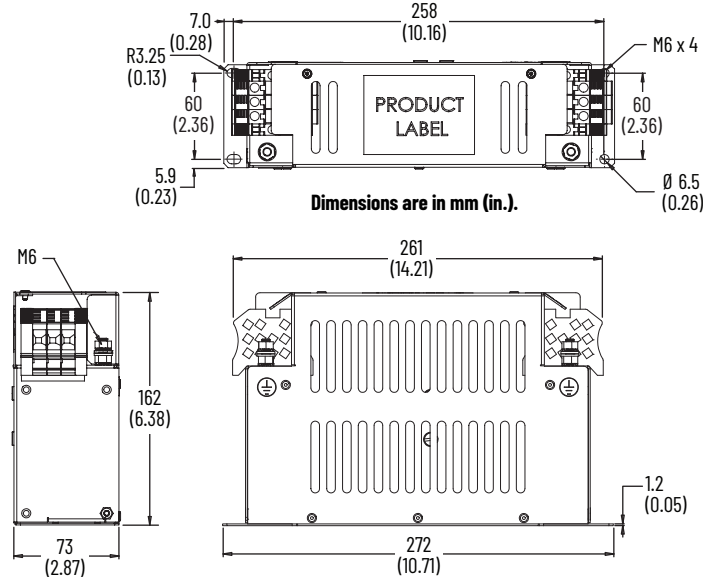

AC Line Filter Dimensions (catalog number 2198-DB80-F)

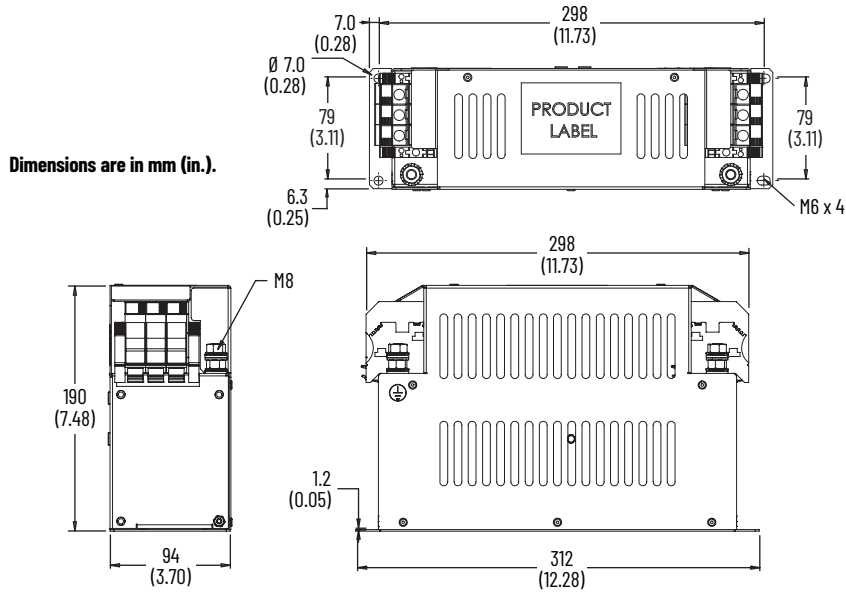

AC Line Filter Dimensions (catalog number 2198-DB290-F)

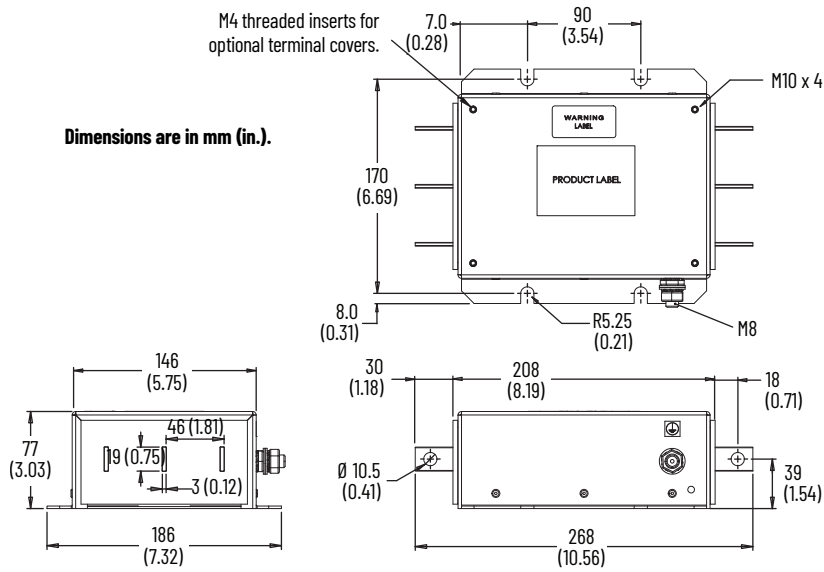

2198-DBxx-F AC Line Filter Specifications

AC Line Filter Cat. No.	Voltage Rating, max	Current Rating A @ 50 °C (122 °F)	Power Loss W	Leakage Current mA	Weight, approx kg (lb)	Operating Temperature
2198-DB20-F	528V AC three-phase 50/60 Hz	20	5.1	5.2	1.63 (3.59)	0...50 °C (32...122 °F)
2198-DB42-F		42	14.7	4.0	2.70 (5.95)	
2198-DB80-F		80	18.3	13.0	3.95 (8.71)	
2198-DB290-F		290	32.7	19.4	4.20 (9.26)	

## Hiperface-to-DSL Feedback Converter Kit

### Converter Kit Dimensions

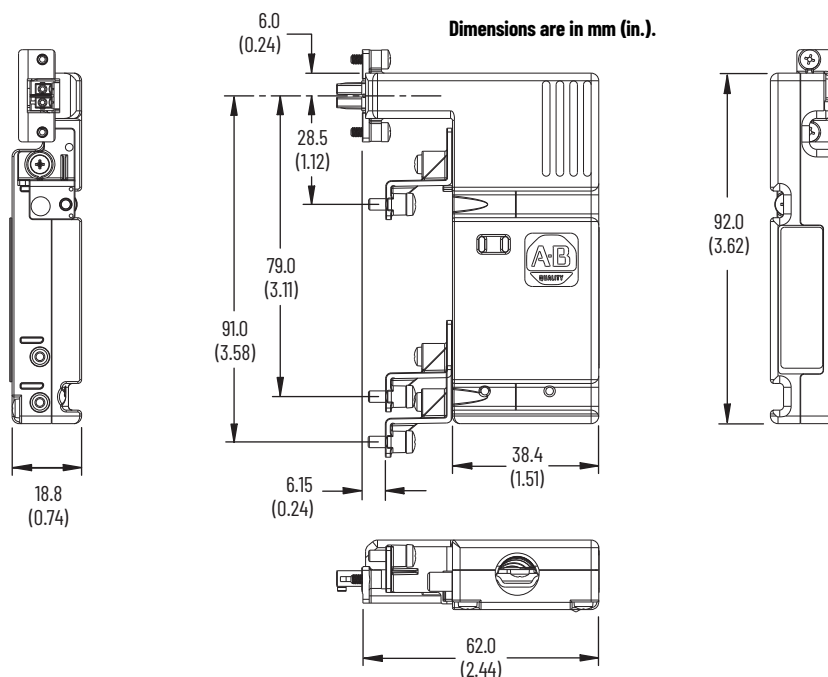

## 24V Shared-bus Connector Kits

24V shared-bus connector kits are used to extend 24V control power from module-to-module. The 24V control power connection system is optional and mounted onto modules working from left to right. 24V shared-bus systems always start with a 24V DC input wiring connector followed by T-connectors and bus-bars. A 24V DC connection system is comprised of these three components:

- The 24V input wiring connector that plugs into the DC-bus power supply or regenerative bus supply and receives input wiring for 24V DC (catalog numbers 2198-TCON-24VDCIN36 or 2198T-W25K-P-IN)
- 24V DC T-connector that plugs into a module downstream and to the right of the 24V input wire connector or previous T-connector.
- Bus bars that connect between a 24V input wiring connector and one or more T-connectors to extend the 24V control power from module to module.

---

**IMPORTANT** The maximum current rating for the 24V input power connection system is 40 A. If needed, you can insert another 2198-TCON-24VDCIN36 or 2198T-W25K-P-IN control power input wiring connector at any point in the drive cluster.

---

Control Power Connector Example

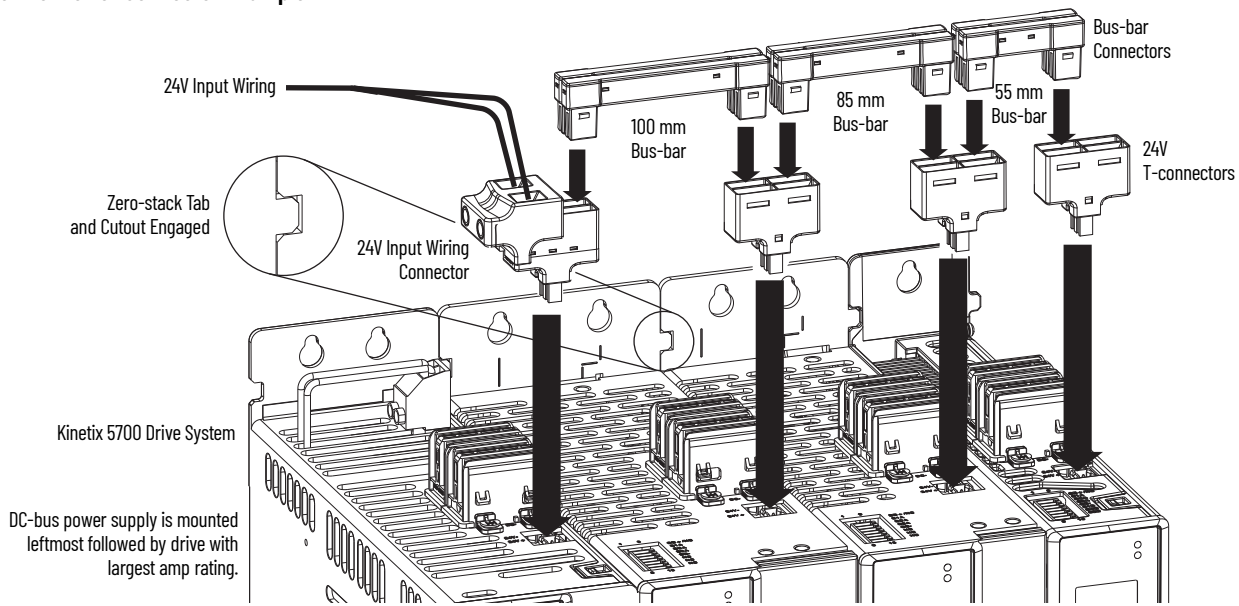

**IMPORTANT** The input wiring connector can be inserted into any drive module (mid-stream in the drive system) to begin a new 24V control bus when the maximum current value is reached. However, the input connector must always extend the 24V DC-bus from left to right.

24V Shared-bus Connector Kit Catalog Numbers

Kit Cat. No.	Description	Module Type	Module Cat. No.	Illustration
2198-TCON-24VDCIN36	Control power input wiring connector	Regenerative bus supplies	2198-RP088, 2198-RP200	 Control Power Input Connector
		DC-bus power supplies	2198-Pxxx	
		Dual-axis inverters	2198-Dxxx-ERSx	
		Single-axis inverters	2198-S086-ERSx	
		Capacitor module	2198-S130-ERSx	
		DC-bus conditioner module	2198-S160-ERSx	
			2198-CAPMOD-2240	
			2198-DCBUSCOND-RP312	
2198T-W25K-P-IN		iTRAK power supply	2198T-W25K-ER	
		Regenerative bus supplies	2198-RP263, 2198-RP312	
		Single axis inverter	2198-S263-ERSx	
			2198-S312-ERSx	
2198T-W25K-P-T		iTRAK power supply	2198T-W25K-ER	
2198-S160-P-T	Control power T-connector Bus-bar connectors, 100 mm, quantity 2	Single axis inverter	2198-S160-ERSx	 Bus-bar Connectors (2x) T-connector
2198-S312-P-T	Control power T-connector Bus-bar connector, 220 mm, quantity 1	Single axis inverter	2198-S263-ERSx 2198-S312-ERSx	 Bus-bar Connector T-connector
2198-H070-P-T	Control power T-connector Bus-bar connectors, 85 mm, quantity 2	DC-bus power supplies	2198-P141 2198-P208	 Bus-bar Connectors (2x) T-connector
		Dual axis inverter	2198-D057-ERSx	
		Single axis inverters	2198-S086-ERSx 2198-S130-ERSx	
2198-H040-P-T	Control power T-connector Bus-bar connectors, 55 mm, quantity 2	DC-bus power supplies	2198-P031 2198-P070	 Bus-bar Connectors (2x) T-connector
		Dual axis inverters	2198-D006-ERSx	
			2198-D012-ERSx	
			2198-D020-ERSx 2198-D032-ERSx	
	Capacitor module	2198-CAPMOD-2240		
	DC-bus conditioner module	2198-DCBUSCOND-RP312		

## Feedback Battery Box Kit

The 2198-KTBT feedback battery-box kit (with user-supplied battery) is used with Kinetix TLP motors when multi-turn positioning is required. 2090-CTFB-MxDD cables include this battery box and the 2198-KTBT battery box kit is available as a replacement. The battery box (with user-supplied battery) retains the multi-turn position over a power cycle.

The absolute encoders used with Kinetix TLP motors can also operate as a single-turn absolute feedback device, however in this case, no battery box (with user-supplied battery) is required to retain the single-turn position over a power cycle.

The customer-supplied 3.6V lithium battery, when installed in the battery box kit, provides multi-turn encoder operation to Kinetix TLP servo motors.

### Battery Specifications

Attribute	Value
International size reference	1/2 AA, ER14252 or equivalent
Capacity, nom @ 0.5 mA, to 2V	1.2 Ah
Rated voltage	3.6V
Continuous current, max	50 mA

### Battery Box Kit Dimensions

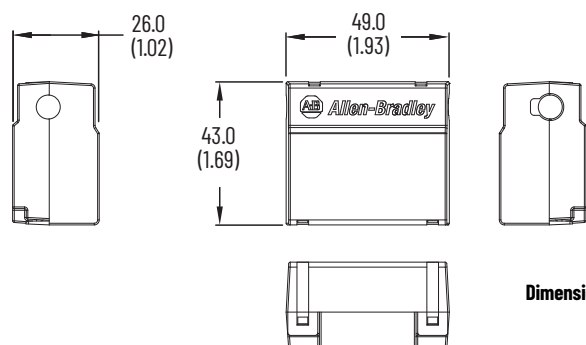

Dimensions are in mm (in.).

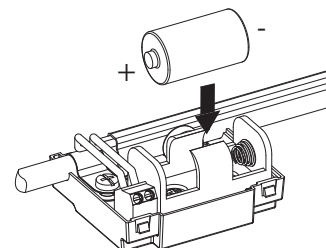

# Motor Overload Protection

Allen-Bradley servo drives use solid-state motor overload protection that operates in accordance with UL requirements. Motor overload protection is provided by algorithms (thermal memory) that predict actual motor temperature based on operating conditions as long as control power is continuously applied.

In addition to thermal memory protection, these drives provide an input for an external temperature sensor/thermistor device, embedded in the motor, to support the UL requirement for motor overload protection.

Servo drives using DSL (digital servo link) encoder technology require the encoder to perform motor temperature monitoring and transmit the data over the single motor cable. Kinetix VP (VPL, VPF, VPH, VPS, and VPC-Bxxxxx-Q) motors use DSL technology that performs this function. No additional wiring is required.

Some motors supported by Kinetix 5500 and Kinetix 5700 drives (firmware revision 3.001 or earlier) do not contain temperature sensors/thermistors; therefore, motor overload protection against excessive consecutive motor overloads with power cycling is not supported. For Kinetix 5500 and Kinetix 5700 drives with firmware revision 4.001 and later, thermal retention is supported regardless of the motor or encoder type in use.

Some motors supported by Kinetix 5100 and Kinetix 5300 drives (Kinetix TLP motors, for example), do not contain temperature sensors/thermistors; therefore, motor overload protection against excessive consecutive motor overloads with power cycling is not supported.

These servo drives meet the following UL requirements for solid-state overload protection.

Motor Overload Protection Trip Point	Value
Ultimately	100% overload
Within 8 minutes	200% overload
Within 20 seconds	600% overload



**ATTENTION:** To avoid damage to your motor due to overheating caused by excessive, successive motor overload trips, follow the wiring diagram provided in the user manual for your motor and drive combination.

Refer to your servo drive user manual for the interconnect diagram that illustrates the wiring between your motor and drive.

## Additional Resources

These documents contain additional information concerning related products from Rockwell Automation.

Resource	Description
Kinetix Rotary Motion Specifications Technical Data, publication <a href="#">KNX-TD001</a>	Product specifications for Kinetix VPL, VPC, VPF, VPH, and VPS; Kinetix MPL, MPM, MPF, and MPS; Kinetix TLY and TL; Kinetix MMA; and Kinetix HPK rotary motors.
Kinetix Linear Motion Specifications Technical Data, publication <a href="#">KNX-TD002</a>	Product specifications for Kinetix MPAS and MPMA linear stages, Kinetix MPAR and MPAL electric cylinders, and Kinetix LDC and LDL linear motors.
Kinetix Rotary and Linear Motion Cable Specifications Technical Data, publication <a href="#">KNX-TD004</a>	Product specifications for Kinetix 2090 motor and interface cables.
Kinetix 3, 300, 350, 2000, 6000, 6200, 6500, 7000 Servo Drives Specifications, publication <a href="#">KNX-TD005</a>	Provides product specifications for Kinetix Integrated Motion over the EtherNet/IP network (Kinetix 6500 and Kinetix 350), Integrated Motion over Sercos interface (Kinetix 6200, Kinetix 6000, Kinetix 2000, and Kinetix 7000), and component (Kinetix 3) servo drive families.
Kinetix Servo Drive Performance Specifications per Ecodesign Regulation (EU) 2019/1781 technical data, publication <a href="#">KNX-TD006</a>	Provides energy efficiency performance data for Rockwell Automation Kinetix Servo drives. This data supports IE2 compliance of Kinetix Servo drives per EU 2019/1781.
iTRAK System Technical Data, publication <a href="#">2198T-TD001</a>	Product specifications for the iTRAK system components, motor modules, movers, and cables.
iTRAK System User Manual, publication <a href="#">2198T-UM001</a>	Information on how to install, configure, startup, and troubleshoot the iTRAK system.
Encoder Output Module User Manual, publication <a href="#">2198-UM003</a>	Provides information on how to access and install the Add On Profile (AOP) and Add-On Instructions for your drive system that includes an encoder output module. Also includes troubleshooting information for your encoder output module.
Motor Protection Circuit Breaker and Motor Circuit Protector Specifications, publication <a href="#">140M-TD002</a>	Provides specifications for Bulletin 140M Motor Protection Circuit Breaker and Motor Circuit Protector.
Motor Protection Circuit Breaker and Motor Circuit Protector Specifications, publication <a href="#">140-TD005</a>	Provides specifications for Bulletin 140MP, 140MT, and 140M Motor Protection Circuit Breaker and Motor Circuit Protector.
1321 Power Conditioning Products Technical Data, publication <a href="#">1321-TD001</a>	Information on typical use cases, specifications, terminations, and dimensions.
Kinetix 5700 Drive Systems Design Guide, publication <a href="#">KNX-RM010</a>	System design guide to determine and select the required (drive specific) drive module, power accessory, connector kit, motor cable, and interface cable catalog numbers for your drive and motor/actuator motion control system. Included are system performance specifications and torque/speed curves (rotary motion) and force/velocity curves (linear motion) for your motion application.
Kinetix 5500 Drive Systems Design Guide, publication <a href="#">KNX-RM009</a>	
Kinetix 5300 Drive Systems Design Guide, publication <a href="#">KNX-RM012</a>	
Kinetix 5100 Drive Systems Design Guide, publication <a href="#">KNX-RM011</a>	
Kinetix 6000 and Kinetix 6200/6500 Drive Systems Design Guide, publication <a href="#">KNX-RM003</a>	
Kinetix 300/350 Drive Systems Design Guide, publication <a href="#">KNX-RM004</a>	
Kinetix 3 Drive Systems Design Guide, publication <a href="#">KNX-RM005</a>	
Kinetix 2000 Drive Systems Design Guide, publication <a href="#">KNX-RM006</a>	
Kinetix 7000 Drive Systems Design Guide, publication <a href="#">KNX-RM007</a>	
Kinetix Motion Control Selection Guide, publication <a href="#">KNX-SG001</a>	Overview of Kinetix servo drives, motors, actuators, and motion accessories designed to help make initial decisions for the motion control products best suited for your system requirements.
System Design for Control of Electrical Noise Reference Manual, publication <a href="#">GMC-RM001</a>	Information, examples, and techniques designed to minimize system failures caused by electrical noise.
Servo Drive Installation Best Practices Application Technique, publication <a href="#">MOTION-AT004</a>	Best practice examples to help reduce the number of potential noise or electromagnetic interference (EMI) sources in your system and to make sure that the noise sensitive components are not affected by the remaining noise.
ControlLogix Selection Guide, publication <a href="#">1756-SG001</a>	Information to determine which ControlLogix controller fits your application and the product specifications to help design a ControlLogix system and select the appropriate components.
CompactLogix Selection Guide, publication <a href="#">1769-SG001</a>	Information to determine which CompactLogix controller fits your application and the product specifications to help design a CompactLogix system and select the appropriate components.
Industrial Ethernet Media Brochure, publication <a href="#">1585-BR001</a>	Information to determine which Bulletin 1585 Ethernet cable fits your application and the product specifications to help select the appropriate components.
Product Certifications website, <a href="http://rok.auto/certifications">rok.auto/certifications</a>	Provides declarations of conformity, certificates, and other certification details.
FactoryTalk Motion Analyzer System Sizing and Selection Tool website <a href="http://rok.auto/motion-analyzer">rok.auto/motion-analyzer</a>	Comprehensive motion application sizing tool used for analysis, optimization, selection, and validation of your Kinetix Motion Control system.
Rockwell Automation Product Selection and Configuration website <a href="http://rok.auto/pcdc">rok.auto/pcdc</a>	Online product selection and system configuration tools, including AutoCAD (DXF) drawings.

You can view or download publications at [rok.auto/literature](http://rok.auto/literature).

# Rockwell Automation Support

Use these resources to access support information.

<b>Technical Support Center</b>	Find help with how-to videos, FAQs, chat, user forums, Knowledgebase, and product notification updates.	<a href="http://rok.auto/support">rok.auto/support</a>
<b>Local Technical Support Phone Numbers</b>	Locate the telephone number for your country.	<a href="http://rok.auto/phonesupport">rok.auto/phonesupport</a>
<b>Technical Documentation Center</b>	Quickly access and download technical specifications, installation instructions, and user manuals.	<a href="http://rok.auto/techdocs">rok.auto/techdocs</a>
<b>Literature Library</b>	Find installation instructions, manuals, brochures, and technical data publications.	<a href="http://rok.auto/literature">rok.auto/literature</a>
<b>Product Compatibility and Download Center (PCDC)</b>	Download firmware, associated files (such as AOP, EDS, and DTM), and access product release notes.	<a href="http://rok.auto/pcdc">rok.auto/pcdc</a>

## Documentation Feedback

Your comments help us serve your documentation needs better. If you have any suggestions on how to improve our content, complete the form at [rok.auto/docfeedback](http://rok.auto/docfeedback).

Allen-Bradley, ArmorKinetix, CompactLogix, ControlLogix, expanding human possibility, FactoryTalk, GuardLogix, Integrated Architecture, iTRAK, Kinetix, Logix 5000, Micro800, MicroLogix, Motion Analyzer, Rockwell Automation, Studio 5000, and Studio 5000 Logix Designer are trademarks of Rockwell Automation, Inc.

CIP Safety, CIP Security, and EtherNet/IP are trademarks of ODVA, Inc.

Trademarks not belonging to Rockwell Automation are property of their respective companies.

Rockwell Automation maintains current product environmental compliance information on its website at [rok.auto/pec](http://rok.auto/pec).

Rockwell Otomasyon Ticaret A.Ş. Kar Plaza İş Merkezi E Blok Kat:6 34752, İçerenköy, İstanbul, Tel: +90 (216) 5698400 EEE Yönetmelğine Uygundur

Connect with us.    

**rockwellautomation.com** ————— expanding **human possibility**<sup>®</sup>

AMERICAS: Rockwell Automation, 1201 South Second Street, Milwaukee, WI 53204-2496 USA, Tel: (1) 414.382.2000, Fax: (1) 414.382.4444

EUROPE/MIDDLE EAST/AFRICA: Rockwell Automation NV, Pegasus Park, De Kleetlaan 12a, 1831 Diegem, Belgium, Tel: (32) 2663 0600, Fax: (32) 2 663 0640

ASIA PACIFIC: Rockwell Automation SEA Pte Ltd, 2 Corporation Road, #04-05, Main Lobby, Corporation Place, Singapore 618494, Tel: (65) 6510 6608, FAX: (65) 6510 6699

UNITED KINGDOM: Rockwell Automation Ltd., Pitfield, Kiln Farm, Milton Keynes, MK11 3DR, United Kingdom, Tel: (44)(1908) 838-800, Fax: (44)(1908) 261-917

Publication KNX-TD003K-EN-P - October 2023

Supersedes Publication KNX-TD003J-EN-P - June 2023

Copyright © 2023 Rockwell Automation, Inc. All rights reserved. Printed in the U.S.A.