

PRODUCT INFORMATION PACKET

Model No: 254TTFCD6028

Catalog No: GT1222A

15 HP General Purpose Motor, 3 phase, 1800 RPM, 230/460 V, 254TC Frame, TEFC
General Purpose Motors



Regal and Marathon are trademarks of Regal Rexnord Corporation or one of its affiliated companies.
©2021 Regal Rexnord Corporation, All Rights Reserved. MC017097E

Nameplate Specifications

Output HP	15 Hp	Output KW	11.2 kW
Frequency	60 Hz	Voltage	230/460 V
Current	37.5/18.8 A	Speed	1772 rpm
Service Factor	1.15	Phase	3
Efficiency	92.4 %	Power Factor	82
Duty	Continuous	Insulation Class	F
Design Code	B	KVA Code	G
Frame	254TC	Enclosure	Totally Enclosed Fan Cooled
Thermal Protection	No	Ambient Temperature	40 °C
Drive End Bearing Size	6309	Opp Drive End Bearing Size	6209
UL	Listed	CSA	Y
CE	Y	IP Code	55
Hazardous Location	DIVISION 2 T2B	Number of Speeds	1

Technical Specifications

Electrical Type	Squirrel Cage Inverter Rated	Starting Method	Line Or Inverter
Poles	4	Rotation	Reversible
Resistance Main	.61 Ohms	Mounting	Rigid Base
Motor Orientation	Horizontal	Drive End Bearing	Ball
Opp Drive End Bearing	Ball	Frame Material	Cast Iron
Shaft Type	T	Overall Length	24.65 in
Frame Length	10.00 in	Shaft Diameter	1.626 in
Shaft Extension	4 in	Assembly/Box Mounting	F1/F2 CAPABLE
Inverter Load	CONSTANT 10:1/VARIABLE 10:1		
Outline Drawing	SS620700-100	Connection Drawing	EE7308K

This is an uncontrolled document once printed or downloaded and is subject to change without notice. Date Created:10/06/2021

DASH NO.	4		3					2		1		
	B	C	E	2E	2F	2FF	AG	AH	BA	BV	MOUNTING	FRAME
100	9.60	24.65	5.00	10.00	---	8.25	20.90	3.75	4.75	9.14	F1 OR F2	254TC
200	11.34	26.39			8.25	10.00	22.64			10.00		254/256TC

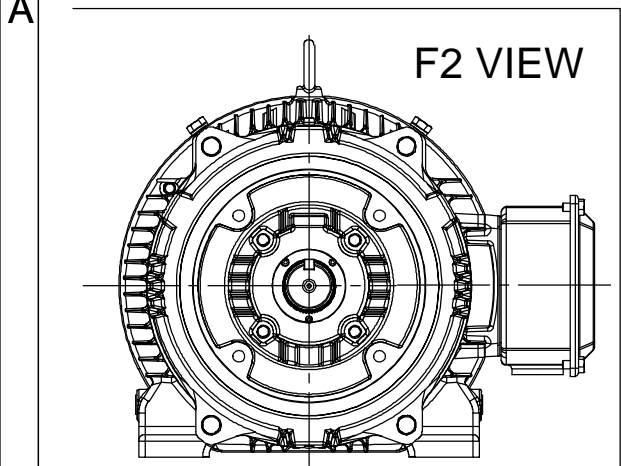
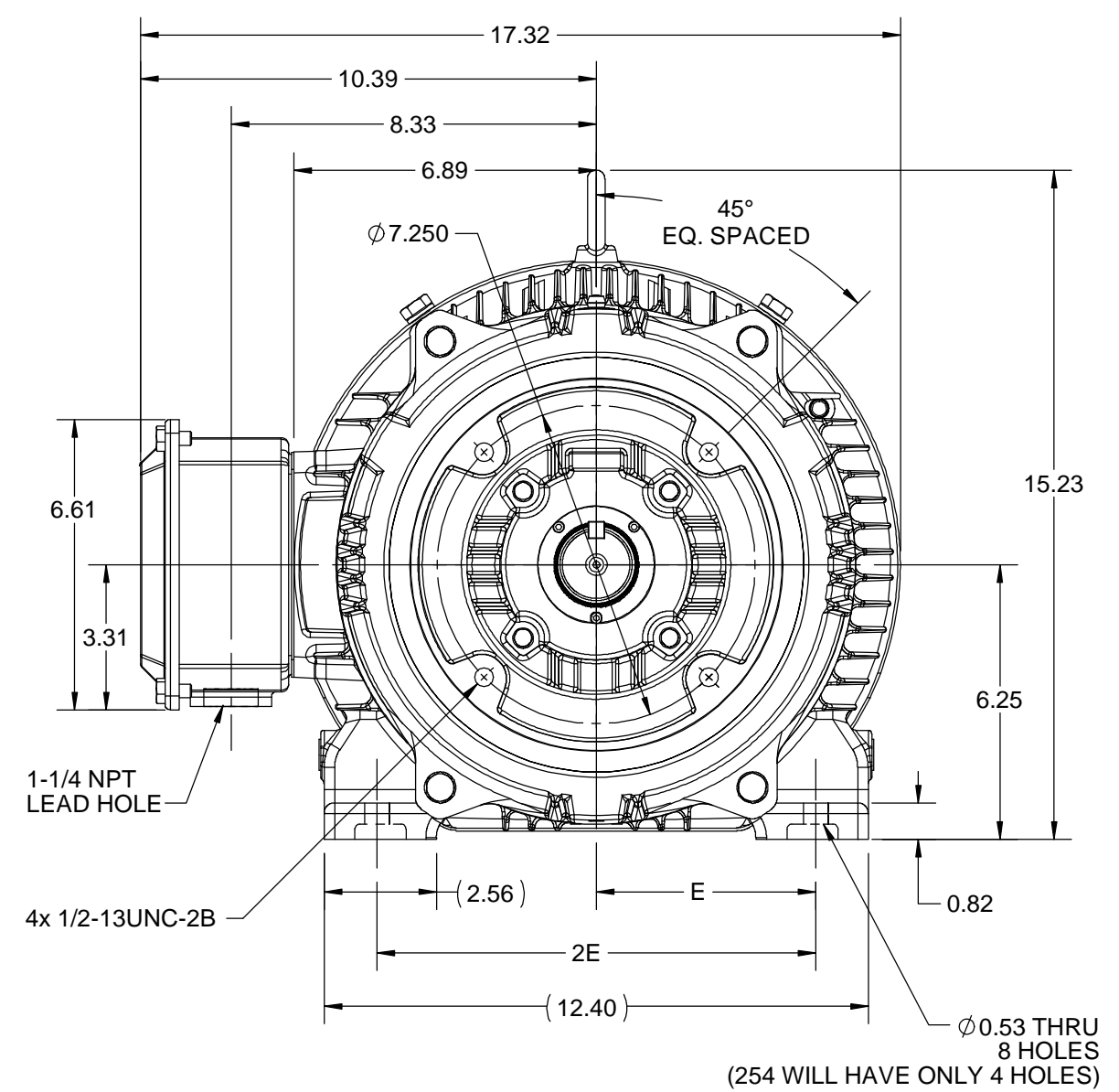
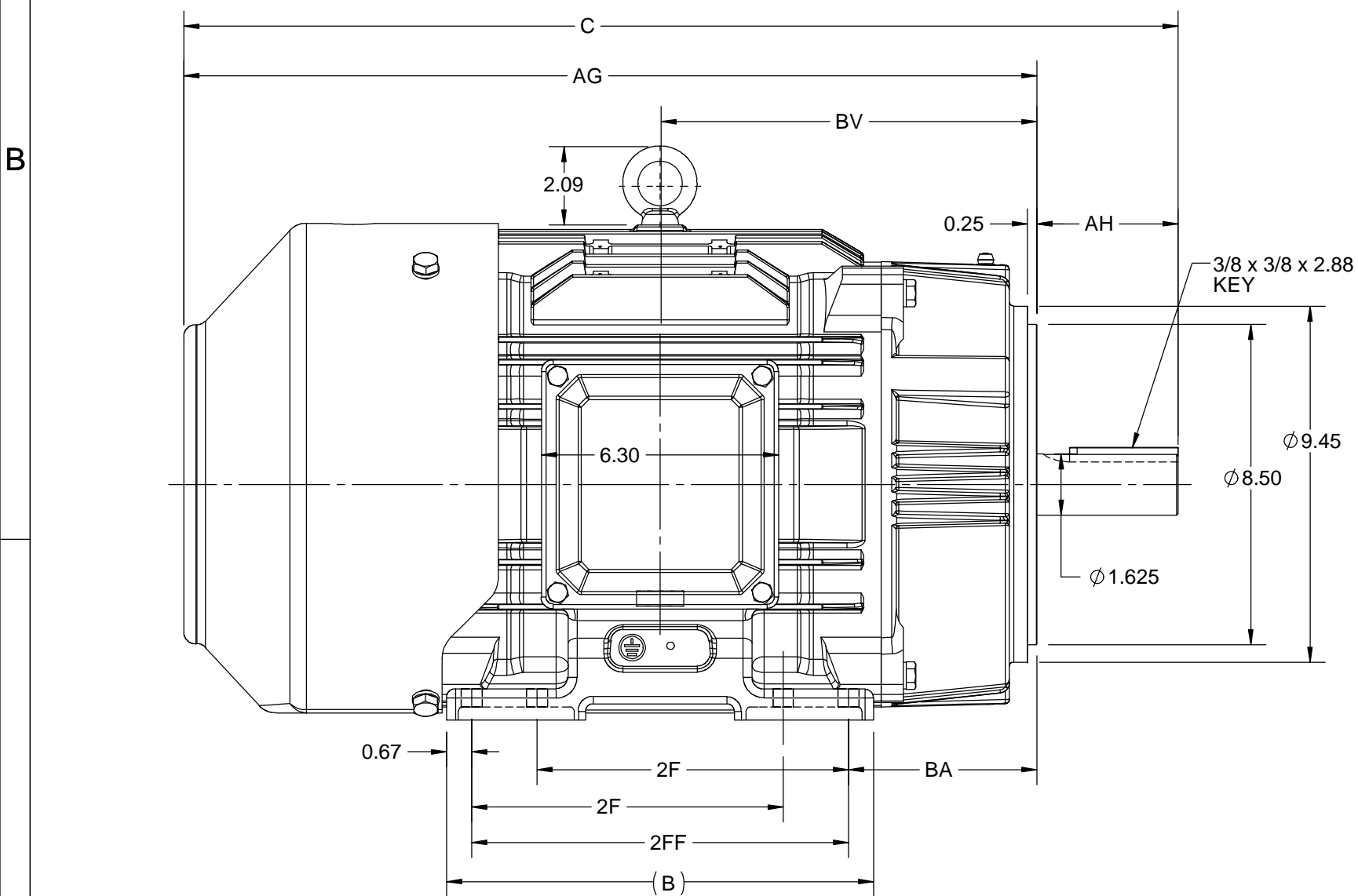

DRAWING REVISION B	REVISION BY BISWA	REV DATE/© DATE 17/09/2020
ECO ECO-0192056	APPROVED BY SBD	DATE 17/09/2020
ECO DESCRIPTION DRAWING UPDATED COPYRIGHT (PER REVISION DATE) REGAL BELOIT AMERICA, INC. ALL RIGHTS RESERVED. PROPRIETARY AND CONFIDENTIAL INFORMATION - THIS DOCUMENT IS THE PROPERTY OF REGAL BELOIT AMERICA, INC. ("OWNER") AND CONTAINS OWNER'S PROPRIETARY INFORMATION. ANY PERSON, CORPORATION OR OTHER FIRM RECEIVING IT IS DEEMED, BY RECEIVING IT, TO AGREE THAT IT, AND/OR ANY PART OF IT, SHALL NOT BE DISCLOSED TO ANY PERSON, CORPORATION OR OTHER ENTITY, DUPLICATED, AND/OR USED, EXCEPT AS EXPRESSLY APPROVED IN WRITING IN ADVANCE BY OWNER. THIS DOCUMENT SHALL BE RETURNED TO OWNER UPON REQUEST. IT MAY BE SUBJECT TO CERTAIN RESTRICTIONS UNDER APPLICABLE EXPORT CONTROL LAWS AND REGULATIONS.		

PRIMARY DIMENSIONS ARE INCH
mm DIMENSIONS IN [BRACKETS]
ARE FOR REFERENCE ONLY

DRAWN BY SMAR	REGAL ® Regal Beloit America, Inc.
DATE 06/07/2015	
APPROVED BY SBD	DESCRIPTION OUTLINE 254/256TC FR-TEFC-CAST IRON
DATE 06/07/2015	MATERIAL PROCESS/FINISH
REFERENCE	SIZE DRAWING NUMBER SHEET
THIRD ANGLE PROJECTION	B SS620700 1 OF 1

LOW VOLTAGE

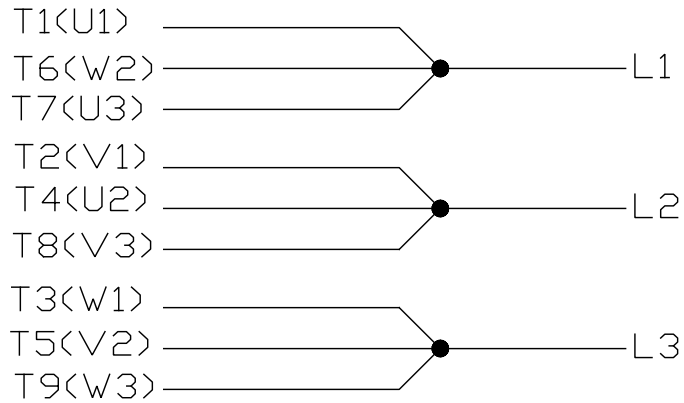

HIGH VOLTAGE



VIEW OF TERMINAL END

				TOLERANCES UNLESS SPECIFIED		 REGAL - BELOIT CORPORATION	DRAWN PGK 06-04-1997	
NO.	REVISION	BY & DATE	CHK	ANG	±		INCHES	CHK
E	CORRECTED IEC MARKINGS ECD-0111208	WGJ 01-23-2017	EMH	DEC.				
D	RE-DRAWN WITH REGAL LOGO ECD-0110493	WGJ 09-30-2016	EMH	.X	±.1			APPD GK 06-15-1997
8	ADDED IEC DESIGNATIONS MU95020	TJW 4/30/2010	MJS	.XX	±.02	TITLE	CONNECTION DIAGRAM	
7	REVISED HIGH VOLTAGE L2 WAS L3 CN52600-354	MRB 09-21-1998		.XXX	±.005		DELTA CON. - 3Ø - 9 LEADS	
6	REDRAWN ON CADD	PGK 06-05-1997		.XXXX	±.0005	MAT'L.	FMF	
					±7'30"	FINISH	PREV	
THIS DRAWING IN DESIGN AND DETAIL IS OUR PROPERTY AND MUST NOT BE USED EXCEPT IN CONNECTION WITH OUR WORK ALL RIGHTS OF DESIGN AND INVENTION ARE RESERVED THIS IS AN ELECTRONICALLY GENERATED DOCUMENT - DO NOT SCALE THIS PRINT						RFP	CAD FILE EE7308K	
						DIST	SIZE	DRAWING NO. PAGE OF
							A	EE7308K
								REV. E



P.O. BOX 8003
WAUSAU, WI 54401-8003
PH. 715-675-3311

DATA VOLTS: 460

CERTIFICATION DATA SHEET

CUSTOMER: _____ CUSTOMER P.O. #: _____
 ORDER #: _____ REFERENCE MODEL #: 254TTFCD6028
 CONN. DIAGRAM: A-EE7308K CAT #: GT1222A
 OUTLINE: B-SS620700 CUSTOMER PART #: _____
 WINDING: HE31604011 NONE 2 MOUNTING: F1/F2 CAPABLE
 SPEED: _____

TYPICAL MOTOR PERFORMANCE DATA

HP	KW	SYNC RPM	FL RPM	FRAME	ENCLOSURE	TYPE	KVA CODE	DESIGN
15	11.2	1800	1772	254TC	TEFC	TFC	G	B

PH	HZ	VOLTS	AMPS	START TYPE	DUTY	INSL	S.F.	AMB	ELEV.
3	60/50	230/460#190/380	37.5/18.8&31.5/15.7	LINE OR INVERTER	CONT	F	1.15	40	3300

F.L. EFF	92.4	3/4 LD EFF	92.4	1/2 LD EFF	91.7	GTD EFF	91.7	ELECT. TYPE	SQ CAGE INV RATED
F.L. PF	82.0	3/4 LD PF	76.5	1/2 LD PF	65.5				

F.L. TORQUE	LR AMPS @ 460 V	L.R. TORQUE	B.D. TORQUE	F.L. RISE (°C)
44.5 LB-FT	113	91.0 LB-FT 204%	118 LB-FT 265%	50

@ 3 FT.	POWER	ROTOR WK ²	MAX. LOAD WK ²	SAFE STALL TIME	STARTS/HOUR	MOTOR WGT
65 dBA	74 dBA	2.40 LB-FT ²	110 LB-FT ²	20 SEC.	2	400 LB.

***** SUPPLEMENTAL INFORMATION *****

DE BRACKET TYPE	ODE BRACKET TYPE	MOUNT TYPE	MOTOR ORIENTATION	SEVERE DUTY	HAZARDOUS LOCATION	DRIP COVER	SCREENS	PAINT
C-FACE	STANDARD	RIGID	HORIZONTAL	NO	NONE	NO	NONE	BLUE (ENAMEL)

BEARINGS		GREASE	SHAFT TYPE	SPECIAL DE	SPECIAL ODE	SHAFT MATERIAL	FRAME MATERIAL
DE	ODE						
BALL	BALL	POLYREX EM	T	NONE	NONE	1045 HOT ROLLED (C-204)	CAST IRON
6309	6209						

THERMOSTATS	PROTECTORS	WDG RTD's	BRG RTD's	THERMISTORS	CONTROL	SPACE HEATERS
NONE	NOT	NONE	NONE	NONE	FALSE	NA

R1 (ohms/ph)	R2 (ohms/ph)	X1 (ohms/ph)	X2 (ohms/ph)	Xm (ohms/ph)	VIBRATION (in/sec)	FLOAT
0.44	0.244	1.304	1.467	31.563	0.150	ODE

* N O T E S *	INVERTER TORQUE: CONSTANT 10:1	
	INV. HP SPEED RANGE: NONE	
	ENCODER: NONE	
	NONE	
	NONE NONE PPR	

PREPARED BY: FAREEDA DUDEKULA	BRAKE: NONE
DATE: 5/3/2018	NONE NONE
	FT-LB: NA
	VOLTAGE: NONE HZ:
FORM: 3531 REV_4 2/27/06	UL: V-INS, CONST UL REC

Data Sheet

254TTFC6028

Date: 5/3/2018
 Customer: _____
 Attention: _____
 Submitted by: FAREEDA DUDEKULA



Submittal

Data @ 460 V

Motor Load Data

Load	0%	25%	50%	75%	100%	115%	125%	LR
Current (Amps)	8.5	9.5	11.8	15.0	18.8	21.0	22.8	113
Torque (ft-lb)	0.00	11.0	22.0	33.5	44.5	51.5	56.0	91.0
RPM	1800	1792	1785	1780	1772	1,768	1762	0
Efficiency (%)		87.5	91.7	92.4	92.4	92.4	91.7	
P.F. (%)	5.0	42.5	65.5	76.5	82.0	83.5	84.0	41.0

Motor Speed Data

	LR	Pull-Up	BD	Rated	Idle
Speed (RPM)	0	900	1622	1772	1800
Current (Amps)	113	100	66.0	18.8	8.5
Torque (ft-lb)	91.0	76.5	118	44.5	0.00

Information Block

HP	15.0			
Sync. RPM	1800			
Frame	254182TTFC6080			
Enclosure	TEFC			
Construction	TFC			
Voltage	230/460#190/380 V			
Frequency	60 Hz			
Design	B			
LR Code letter	G			
Service Factor	1.15			
Temp Rise @ FL	50 °C			
Duty	CONT			
Ambient	40 °C			
Elevation	1,000 feet			
Rotor/Shaft wk ²	2.40 Lb-Ft ²			
Ref Wdg	HE31604011 NONE			
Sound Pressure @ 1M	65 dBA			
VFD Rating	CONSTANT 10:1			
Outline Dwg	B-SS620700			
Conn. Diag	A-EE7308K			
Additional Specifications:				
0				
0				
EQUIV CKT (OHMS / PHASE)				
R1	R2	X1	X2	Xm
0.4400	0.2440	1.3040	1.4670	31.5630

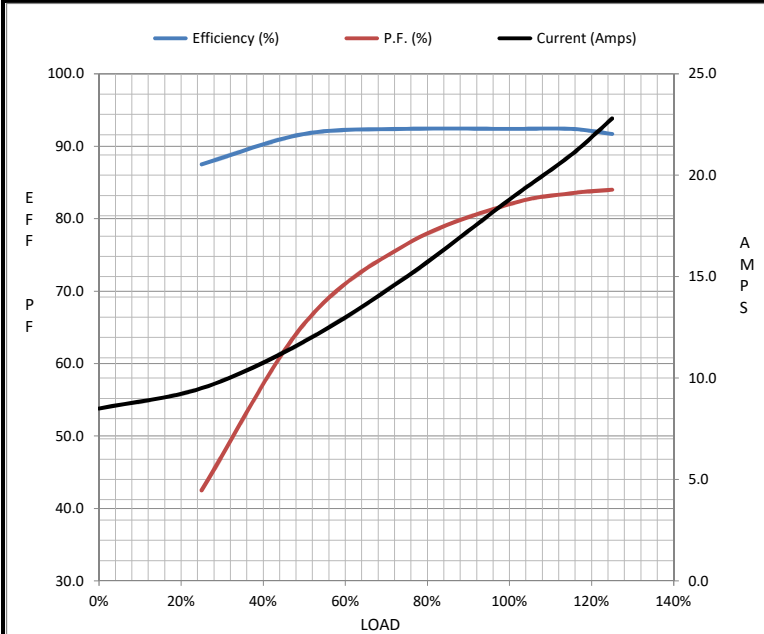

Speed - Torque Curve

