

# RightSight M30 Background Suppression and Reflection Sensor

Catalog Numbers 42AF-B1MAB1-D4, 42AF-B1MAB1-F4, 42AF-B1MAB2-D4, 42AF-B1MAB2-F4, 42AF-B1MAC1-D4, 42AF-B1MAC1-F4, 42AF-N1MAC1-D4, 42AF-N1MAC1-F4

**IMPORTANT** Save these instructions for future use.

Topic	Page
Summary of Changes	1
Description	1
Features	1
RightSight M30 Configuration	2
Background Suppression Teach Process	2
Background Reflection Teach Process	3
Teach Light Operate (L.O.) or Dark Operate (D.O.)	3
Output Type Selection: Auto PNP/NPN, Dedicated NPN, Dedicated PNP	3
Push Button Lock/Unlock	3
Wiring Diagrams	4
Accessories	5
Typical Beam Patterns	5
Typical Sensing Range Performance	5

## Summary of Changes

Updated catalog numbers for IO-Link, added warning information regarding product range to targets with low reflectivity, and added missing “3 seconds” callout to the Background Reflection Teach Process graphic.

## Description

The RightSight™ M30 Background Suppression sensor is a time of flight-based sensor that provides accurate detection regardless of target reflectivity. Background suppression sensing modes are ideal for applications where highly reflective backgrounds must be ignored while helping to detect targets reliably within the specified range.

This family offers a background reflection/foreground suppression sensing mode that enables operators to use the surface of a background (for example, a conveyor) as a reflector. The detection of a target occurs once an object blocks the visual path between the sensor and the background (for example, conveyor).

## Features

- Sensing Ranges
  - 400 mm (15.7 in.) and 600 mm (23.6 in.) sensing range models without physical adjustments,
  - 1.2 m (3.94 ft) sensing range with push button teach,
  - 800 mm (31.5 in.) push button teach background reflection models.
- All models can be taught to detect targets up to 4 m (13.1 ft.) when using IO-Link and to adjust the response time.
- High powered light source for ease of alignment.
- 360° highly visible user interface helps operators verify the proper operation, regardless of the sensor installation location.
- Background suppression performance minimizes false detections due to highly reflective backgrounds.
- Dual Auto PNP/NPN helps streamline inventory by reducing the number of catalog numbers to stock.
- Push button lock prevents unauthorized operators from changing the sensor settings.
- Embedded IO-Link 1.1 communications protocol.
- Adjustable sensing ranges and response time via IO-Link provides additional flexibility to detect targets at longer or shorter distances depending on the application requirements.
- IP67 and IP69K rated enclosure.

**Figure 1 - Status Indicator**

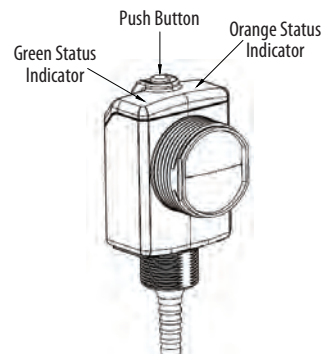

[Table 2 on page 2](#) provides indicator status in the Run mode, during operation. The sensor is always in Run mode except when being taught.

**Table 2 - Standard I/O (Auto PNP/NPN) Operating Mode Indication**

Indicator Color	State	Description
Green	OFF	Power is OFF
	ON	Power is ON
	Flashes (5 Hz)	Marginal Signal <sup>(1)</sup>
	Flashes (1.5 Hz)	Output short circuit protection active
	Flashes for 3 seconds at 5 Hz <sup>(2)</sup>	Insufficient signal to set detection distance
Orange	OFF	Output de-energized
	ON	Output energized

(1) For background suppression sensing mode, this condition indicates that the target is close to the defined output switching distance. For the background reflection sensing mode, this condition indicates that there's insufficient signal or that the target is close to the defined output switching distance.

(2) The sensor only indicates this condition when the operator performs a static or precision teach operation.

**Table 3 - IO-Link Operating Mode Indication**

Indicator Color	State	Description
Green	OFF	Power is OFF
	Flashes (1 Hz)	Power is ON
Orange	OFF	Output de-energized
	ON	Output energized

## RightSight M30 Configuration

The RightSight M30 Background Suppression sensor can be configured using the push button or IO-Link with the help of the status indicators on the sensor. These features can be configured:

- Teach sensing range (standard or precision teach)
- Background suppression and background reflection sensing modes via IO-Link
- Light operate (L.O.) or dark operate (D.O.) output
- Auto PNP/NPN or dedicated PNP
- Changes in the operating response time
- Push button lock/unlock

## Background Suppression Teach Process

The following are the factory default settings for each of the available models.

### 42AF-B1MAB1-D4 and 42AF-B1MAB1-F4 — 400 mm Model

Sensing Range: Teachable up to 4 m (13.1 ft) using IO-Link.  
 Sensing Mode: Background Suppression  
 Response Time: 5.5 ms  
 Physical Adjustment: None  
 Response Time Options: 5.5 ms, 8 ms, 13 ms, 21 ms, 39 ms, 75 ms

### 42AF-B1MAB2-D4 and 42AF-B1MAB2-F4 – 600 mm Model

Sensing Range: Teachable up to 4 m (13.1 ft) using IO-Link.  
 Sensing Mode: Background Suppression  
 Response Time: 8 ms  
 Physical Adjustment: None  
 Response Time Options: 5.5 ms, 8 ms, 13 ms, 21 ms, 39 ms, 75 ms

### 42AF-B1MAC1-D4 and 42AF-B1MAC-F4 — 1.2 m Model

Sensing Range: Teachable up to 3 m (9.84 ft) using the push button and up to 4 m (13.1 ft) using IO-Link.  
 Sensing Mode: Background Suppression  
 Response Time: 8 ms  
 Physical Adjustment: Push button  
 Response Time Options: 5.5 ms, 8 ms, 13 ms, 21 ms, 39 ms, 75 ms

### 42AF-N1MAC1-D4 and 42AF-N1MAC1-F4 — 800 mm Model

Sensing Range: Teachable up to 3 m (9.84 ft) using the push button and up to 4 m (13.1 ft) using IO-Link.  
 Sensing Mode: Background Reflection  
 Response Time: 8 ms  
 Physical Adjustment: Push button  
 Response Time Options: 5.5 ms, 8 ms, 13 ms, 21 ms, 39 ms, 75 ms

The sensor operating mode, response time, and sensing range can be changed using IO-Link. This change in parameters is also possible on devices without physical adjustments.

## Static Teach (Background Suppression Mode)

For Static Teach, to teach the sensitivity/sensing range is a two-step process: teach target (first condition) and teach background (second condition). Switching threshold for output ON vs. OFF is set in between the two conditions.

1. Teach the target (first condition)

t > 3 s

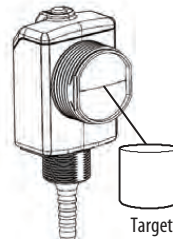

- a. Place the target at the desired distance.
- b. Press and hold the button for three seconds until the orange indicator starts to flash.
- c. Release the button. The first condition has now been taught.

2. Teach the background (second condition)

t < 1 s

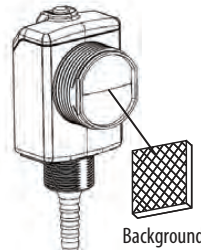

- a. Remove the target.
- b. Press and release the button. The teach process is complete. If the push button is not pressed within 30 seconds, the sensor exits Teach mode and returns to Run mode without learning the new teach settings.

## Precision Teach (Background Suppression)

For a more precise setting, do not remove the target in step two (for example, the target is present for both step one and step two).

For the default response time of 8 ms, the maximum sensing range can be set to detect a target up to 2 m (6.56 ft) for a 90% white paper. There may be a slight variation from unit to unit.

To set the sensing range to the factory default value of 1.2 m (3.94 ft) range, you must place a 90% white paper at this distance and perform a precision teach process. The factory default value can also be changed by executing a factory reset when operating in IO-Link.

While performing the teach process, if the target reflectivity is not sufficient for the sensor to determine a good detection point, the green LED flashes at 5 Hz for 3 seconds. This process indicates the teach was unsuccessful.

### Minimum Separation between Object and Background

The background must be at least 100 mm (3.94 in.) away from the target to be sure of good detection.

The minimum separation could be increased when operating the sensor with response times different than the factory defaults. This separation is especially important if there's a high reflectivity object in the field of view.

## Background Reflection Teach Process

The RightSight M30 sensor features a background reflection sensing mode that enables operators to use the surface of a background (for example, a conveyor) as a reflector. When operating in background reflection mode, the sensor detects the presence of a target when the optical path between the background and the reflector is interrupted. This sensing mode requires a minimum separation of at least 100 mm (3.94 in.) from the background to be sure of good detection.

t > 3 s

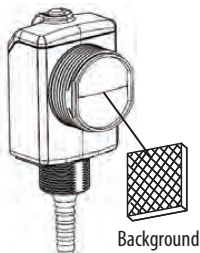

- Align the sensor to the background.
- Press and hold the button for three seconds until the orange indicator starts to flash.
- Release the button.
- Press the button again for less than one second to complete the teach process.

Depending on the reflectivity of the background and the response time, longer sensing ranges than the default settings can be achieved.

## Teach Light Operate (L.O.) or Dark Operate (D.O.)

The default setting of the output is Light Operate. The L.O. setting means that output turns ON when the target is detected. If the application requires the output to turn OFF when the target is detected, the setting can be changed to dark operate (D.O.).

To access the Teach Output mode setting, follow these steps.

t > 6 s

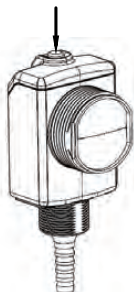

- Press and hold the button for six seconds, until the green indicator starts to flash.
  - Release the button.
- The orange indicator indicates the current setting.
- L.O.: Orange indicator ON  
D.O.: Orange indicator OFF

To change the Sensor Output mode setting, follow these steps:

t < 1 s

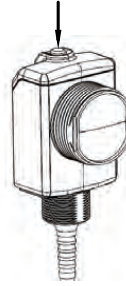

- Press and release the button within 10 seconds to toggle from L.O. to D.O. The orange indicator indicates the selection.
- The sensor retains the setting per the last button depression and returns to the run mode 10 seconds after the last button is depressed.

## Output Type Selection: Auto PNP/NPN, Dedicated NPN, Dedicated PNP

The default setting is Auto PNP/NPN. The sensor monitors the load connection and automatically configures for the proper operation, for example, PNP or NPN. If no load is connected, the sensor defaults to PNP.

The following applications are covered with dedicated PNP or dedicated NPN selection:

- Parallel wiring of multiple sensor outputs: select dedicated PNP or dedicated NPN setting, as needed.
- Select dedicated NPN if the load is connected to another power supply than the power used for the sensor.

Selection can be made as follows:

- To access output type: Press and hold the push button for 12 seconds (until both indicators start flashing synchronously). At the release of the button, the slow flashing of the indicator (or indicators) shows the current setting of the output type as follows:
  - Auto PNP/NPN: Both indicators flash (synchronously)
  - Dedicated NPN: Green indicator flashes
  - Dedicated PNP: Orange indicator flashes
- To change output type: To select desired type, press and release the push button within 10 seconds. Each press of the button cycles to the next output setting. The indicators show the type that is selected. The sensor retains the setting per the last button depression and returns to the run mode 10 seconds after the last button is pressed.

## Push Button Lock/Unlock

The push button can be used to help prevent unauthorized users from changing teach settings.

To lock the push button: Press and release the button three times within three seconds. Both indicators flash synchronously for three seconds to indicate that the push button is now locked.

To unlock the push button: Press and release the button three times within three seconds. Both indicators flash asynchronously for three seconds to indicate that the push button is now unlocked.

## Wiring Diagrams

The quick-disconnect connector is shown in [Figure 3](#). The pin numbers correspond to the male connectors on the sensor.

**Figure 3 - Micro (M12) Male QD Pigtail/ Male QD**



M12 Male QD

**Figure 4 - Output Wiring**

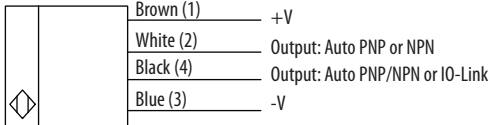

**Figure 5 - Integral M12 Connector Dimensions [mm (in.)]**

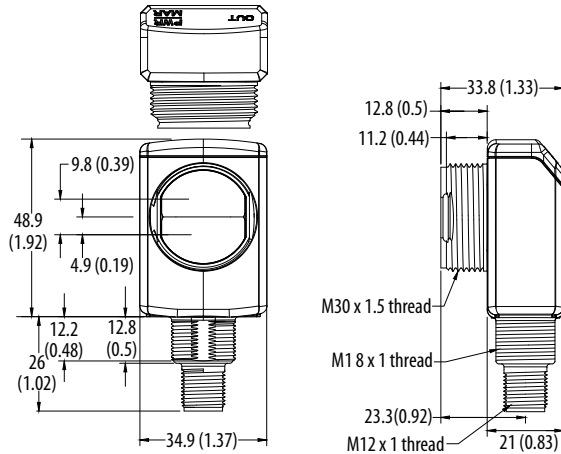

**Figure 6 - M12 Pigtail and Cable Models [mm (in.)]**

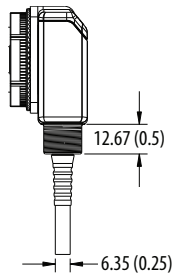

**Table 7 - Specifications**

Attribute	42AF-B1MAB1-F4, 42AF-B1MAB1-F4, 42AF-B1MAB1-F4, 42AF-B1MAC1-F4, 42AF-B1MAC1-D4, 42AF-N1MAC1-D4, 42AF-N1MAC1-F4
Certifications	c-UL-us, and CE Marked for all applicable directives
Vibration	10...55 Hz, 1 mm (0.04 in.) amplitude, meets, or exceeds 60947-5-2
Shock	30 g with 1 ms pulse duration per IEC 60947-5-2
Ambient light immunity	Direct Illumination: 20,000 lux; Indirect Illumination: 5000 lux Sunlight immunity: 108,000 lux
<b>User Interface</b>	
Status indicators	Green and Orange LED
<b>Electrical</b>	
Adjustments	Push button and no physical adjustment. All models are adjustable using IO-Link.
Operating voltage	DC models: 10...30V DC, IO-Link: 18...30V
Current consumption	35 mA max
Sensor protection	DC: Reverse polarity and short circuit
<b>Discrete Output</b>	
Response time	DC: 5.5 ms, 8 ms, 13 ms, 21 ms, 39 ms, 75 ms
Output type	DC: Dual Auto PNP or NPN
Load current	DC: 100 mA max for both outputs
<b>IO-Link</b>	
Communications mode	COM2
Cycle time, min	2 ms
Process data bit length	32 bits (4 bytes)
Specifications	1.1
<b>Mechanical</b>	
Housing material	PBT
Lens material	PMMA
Cover material	Polysulfone
<b>Reliability Data</b>	
Background Suppression and Background Reflection	
MTTFd (hours)	5474425 hours
T10d	65.8
<b>Environmental</b>	
Enclosure type rating	IP67 and IP69K per IEC 60529
Operating temperature	-40...+70 °C (31...158 °F) <sup>(1)</sup>
Connection type	4-pin Integral M12 QD 4-pin M12 QD on a 150 mm (5.9 in.) pigtail

(1) The sensing range for all sensing modes can be reduced up to 20% when operated between -40...-25 °C (-40...-13 °F).

**IMPORTANT** The product range to targets with low reflectivity may decrease if the cables are coupled to high frequency drives or other sources of external interference in the 4...5 MHz or 8...10 MHz ranges.

## Accessories

**Figure 8 - 30 mm Right Angle Mounting Bracket**

Cat. No. 60-2421

Cat. No. 60-2439

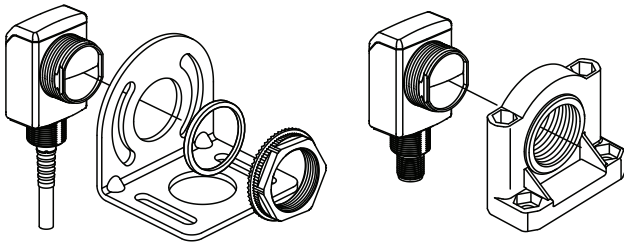

**Figure 9 - 18 mm Swivel/tilt Mounting Bracket**

Cat. No. 60-2649

Cat. No. 60-2681

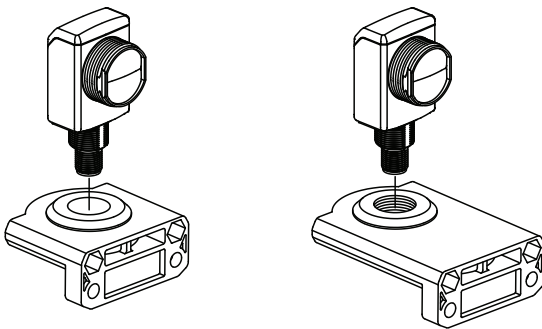

## Typical Beam Patterns

**Figure 10 - 400 mm Beam Pattern (Cat. No. 42AF-B1MAB1-xx) Model**

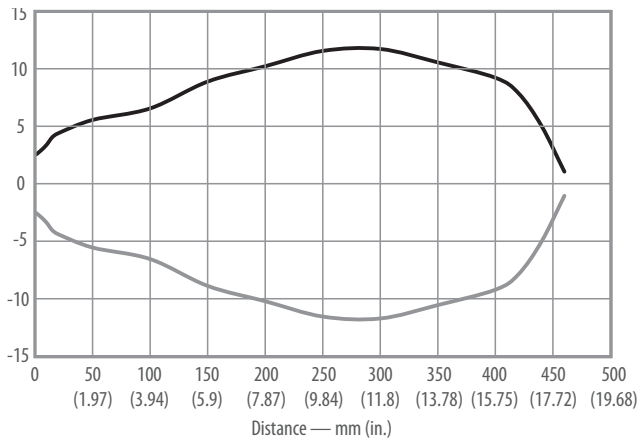

**Figure 11 - 600 mm Beam Pattern (Cat. No. 42AF-B1MAB2-xx) Model**

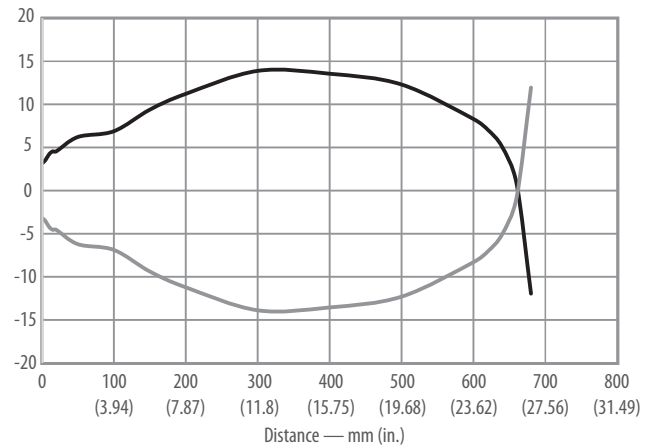

**Figure 12 - 1200 mm Beam Pattern (Cat. No. 42AF-B1MAC1-xx) Model**

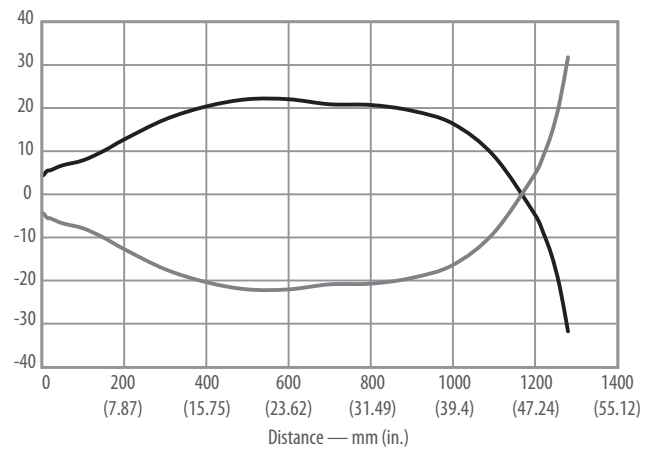

## Typical Sensing Range Performance

The RightSight M30 sensor can be taught to detect objects at longer ranges depending on the selected response time. [Table 13](#) shows the typical expected range when a certain response time has been selected.

**Table 13 - Range and Response Times**

Response Time [ms]	Teachable Range 90% White [m (ft)]	Teachable Range 6% Black [m (ft)]
5.5	2 (6.56)	750 mm (29.53 in.)
8	4 (13.12)	1.2 (3.94)
13	4 (13.12)	2 (6.56)
21	4 (13.12)	4 (13.12)
39	≥ 4 (13.12)	4 (13.12)
75	≥ 6 (19.68)	4 (13.12)

The sensing ranges that are listed in [Table 13](#) are possible when changing the response time of the sensor in IO-Link mode. A change to the response time can also increase the sensing range. In this scenario, it is possible for highly reflective objects (reflector or reflective vest) to be detected slightly beyond the set detection threshold.

To be sure you are not seeing undesired highly-reflective objects in the background, we recommend that you verify that the set distance adequately ignores this target.

# Rockwell Automation Support

Use the following resources to access support information.

<b>Technical Support Center</b>	Knowledgebase Articles, How-to Videos, FAQs, Chat, User Forums, and Product Notification Updates.	<a href="https://rockwellautomation.custhelp.com/">https://rockwellautomation.custhelp.com/</a>
<b>Local Technical Support Phone Numbers</b>	Locate the phone number for your country.	<a href="http://www.rockwellautomation.com/global/support/get-support-now.page">http://www.rockwellautomation.com/global/support/get-support-now.page</a>
<b>Direct Dial Codes</b>	Find the Direct Dial Code for your product. Use the code to route your call directly to a technical support engineer.	<a href="http://www.rockwellautomation.com/global/support/direct-dial.page">http://www.rockwellautomation.com/global/support/direct-dial.page</a>
<b>Literature Library</b>	Installation Instructions, Manuals, Brochures, and Technical Data.	<a href="http://www.rockwellautomation.com/global/literature-library/overview.page">http://www.rockwellautomation.com/global/literature-library/overview.page</a>
<b>Product Compatibility and Download Center (PCDC)</b>	Get help determining how products interact, check features and capabilities, and find associated firmware.	<a href="http://www.rockwellautomation.com/global/support/pcdc.page">http://www.rockwellautomation.com/global/support/pcdc.page</a>

## Documentation Feedback

Your comments will help us serve your documentation needs better. If you have any suggestions on how to improve this document, complete the How Are We Doing? form at [http://literature.rockwellautomation.com/idc/groups/literature/documents/du/ra-du002\\_-en-e.pdf](http://literature.rockwellautomation.com/idc/groups/literature/documents/du/ra-du002_-en-e.pdf).

## Waste Electrical and Electronic Equipment (WEEE)



At the end of life, this equipment should be collected separately from any unsorted municipal waste.

Rockwell Automation maintains current product environmental information on its website at <http://www.rockwellautomation.com/rockwellautomation/about-us/sustainability-ethics/product-environmental-compliance.page>.

Allen-Bradley, RightSight, Rockwell Automation, and Rockwell Software are trademarks of Rockwell Automation, Inc. Trademarks not belonging to Rockwell Automation are property of their respective companies.

Rockwell Otomasyon Ticaret A.Ş., Kar Plaza İş Merkezi E Blok Kat:6 34752 İçerenköy, İstanbul, Tel: +90 (216) 5698400

**[www.rockwellautomation.com](http://www.rockwellautomation.com)**

### Power, Control and Information Solutions Headquarters

Americas: Rockwell Automation, 1201 South Second Street, Milwaukee, WI 53204-2496 USA, Tel: (1) 414.382.2000, Fax: (1) 414.382.4444  
Europe/Middle East/Africa: Rockwell Automation NV, Pegasus Park, De Kleetlaan 12a, 1831 Diegem, Belgium, Tel: (32) 2 663 0600, Fax: (32) 2 663 0640  
Asia Pacific: Rockwell Automation, Level 14, Core F, Cyberport 3, 100 Cyberport Road, Hong Kong, Tel: (852) 2887 4788, Fax: (852) 2508 1846

Publication 42AF-IN002B-EN-P - June 2019

Supersedes Publication 42AF-IN002A-EN-P - March 2019

PN-533940  
10004637043 Ver 01

Copyright © 2019 Rockwell Automation, Inc. All rights reserved. Printed in the U.S.A.