

# Sensor Application Guide

May 2011

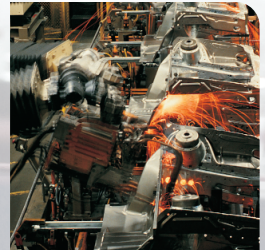

LISTEN.  
THINK.  
SOLVE.®

# Table of Contents

---

<b>Preface</b> .....	<b>i</b>
Determine Where a Sensor May Be Needed.....	i
Determine if a Sensor Should Be Applied.....	ii
Determine the Physical Properties of What You Are Detecting .....	iv
<b>Packaging</b> .....	<b>1-1</b>
Bagging.....	1-2
Capping .....	1-3
Cartoning .....	1-4
Case Packing.....	1-5
Depalettizing.....	1-6
Depalletizing (2).....	1-7
Filling .....	1-8
Filling/Lidding/Capping .....	1-9
Labeling .....	1-10
Presort.....	1-11
Processing.....	1-12
Wrapping .....	1-13
<b>Material Handling</b> .....	<b>2-1</b>
Extendable Shipping Conveyors.....	2-2
Automatic Palletizer .....	2-3
Palletizing .....	2-4
Receiving Docks .....	2-5
Turntables .....	2-6
<b>Automotive</b> .....	<b>3-1</b>
Body Assembly .....	3-2
E-Coat Tanks .....	3-3
Engine Transmission.....	3-4
Material Transfer System .....	3-5
Oven .....	3-6
Paint Robots .....	3-7
Plastic Components Plant .....	3-8
Press & Fabrication Plant .....	3-9
Spray Reciprocators .....	3-10
<b>Glossary</b> .....	<b>4-1</b>

# Preface

---

## Sensor Selection—A Methodical Approach

Within each system there are many operations or processes: fabrication, assembly, packaging, painting, material handling. Each can be broken down into smaller events like counting, indexing, ejection, spraying, filling, and conveying. A sensor could be of value to detect the changing conditions associated with an action or event. The following outlines a general method for specifying the best sensing solution for an application.

### Determine Where a Sensor May Be Needed

This process involves identifying key operations within the system and defining focus areas where conditions should be verified.

#### Identify the Functions

Identify what the system does or what you want it to do. Is it necessary for you to count product? Sort? Perform a quality check? Determine part orientation?

Specifically:

- What conditions must be met for each function to occur?
- What feedback is required during each function?
- What conditions must be met after each function to verify the function has occurred properly?

#### Identify the Area of Focus

Focus on the area where an action is taking place. Within this area, you will typically find a work piece and a mechanism that acts upon it. Investigate both to determine what is required for the function to be properly executed.

- Verification of work piece—Are there features or components of the work piece that must be present or in a particular orientation? What is the potential for the work piece itself to be oriented or damaged in a way that could adversely affect the process?

- Verification of mechanism—Is the mechanism or work piece driven by separate systems that could crash if one were present without the other being retracted? Is a particular component prone to breakage or wear?

**Figure 0.1 Bottling process areas of focus**

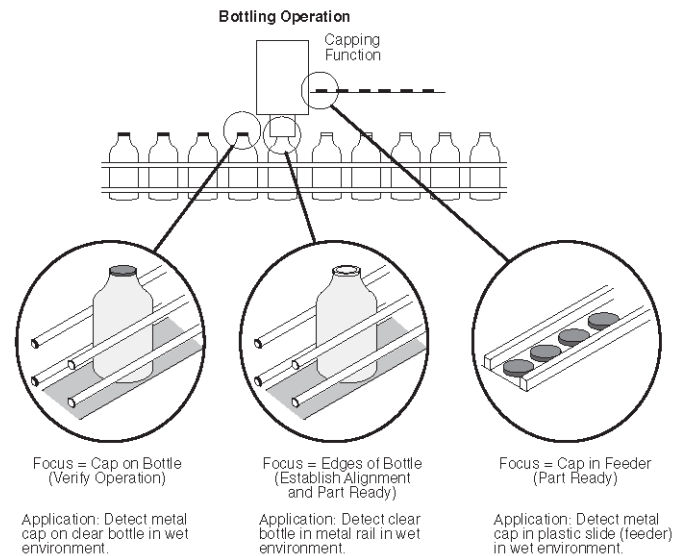

## Determine if a Sensor Should Be Applied

You must now decide how important each of the areas you identified is to the process. The higher the level of automation the more important it is for these functions to execute properly. Specifically, you are asking:

- What is the impact of damage or loss?
- What is the likelihood of it occurring?
- How critical is it to process integrity?

If the answer to any one of these is “high,” you need to consider implementing a sensor to monitor the system. The next step is to define what sensing functions need to be achieved and where the best location is to accomplish them.

## Define the Application

You have identified an application that can benefit from



---

implementing a sensor to detect a changing condition. With this as your focus, you must now determine:

- Available power
  - Output/Load requirements
  - Target characteristics
  - Environmental conditions
- Identify the Power Sources

### Identify the Power Sources

Based on the voltage commonly available in the field, sensors are generally designed to fall within one of four voltage ranges:

- 10-30V DC
- 20-130V AC
- 90-250V AC
- 20-250V AC/DC

AC sensors and switches can receive power directly from a power line or filtered source, eliminating the need for a separate power supply. AC devices and connection methods are also perceived as being more rugged.

DC sensors require a separate supply to create and isolate the DC voltage from the AC signal. However, with voltages typically less than 30V, DC is considered safer than AC. DC sensors come in current source (PNP) and current sink (NPN) versions. Current source sensors supply power to the load which must be referenced to the ground or negative rail of the power supply. Current sink sensors supply ground to the load which must be referenced to a positive voltage that shares the same ground.

AC/DC devices operate over a wide range of voltages from either power source. As a matter of general practice, you want to specify that your switches or sensors are powered from a stable source that is free of noise. Typically, this involves specifying an isolated line or separate supply to power the switches and sensors and staying well within the ratings.

---

### **Identify the Load Requirements**

The electrical components in series between the sensor output and power or ground constitute what is referred to as the input load of the device and output load for the sensor. This load translates the electrical signals of the sensor output into electrical, mechanical, sound or light energy that initiates a change within the affected device.

Key characteristics of the three types of circuit elements that can be found in the load:

- Resistive elements constitute an ideal type of load, dissipating power in direct proportion to the voltage applied.
- Capacitive elements are reactive and can appear to be a short circuit when first switched on.
- Inductive elements like relay coils and solenoids are also reactive elements that can create high voltage transients when switched off abruptly.

### **Determine the Physical Properties of What You Are Detecting**

For any sensing function you must identify the item you wish to detect (target); this may be an entire object or a feature of that object. You must also determine the variables associated with the target—presence, position, orientation, etc.—and how these variables affect the process. Finally, we must regard environmental conditions and their effects; insuring that the surroundings do not contain factors that affect the technology is an enormous factor in the reliability of the application.

#### **Target Considerations**

Properties of the target—size, material, color, opacity, etc.—will dictate the use of a particular technology and define limitations within that technology. For example, inductive sensors will only detect metal targets. However, the size and material of the target affect sensing range and speed.

---

### **Identify Environmental Influences**

There are characteristics of the target, background and surroundings that influence the ability to differentiate one from the other. Ideally, the changing condition of the target you are trying to detect should be unique from related factors in the background and surroundings.

### **Sensor Selection**

Now that you have documented the application and understand what must be detected, our discussion can be directed toward selecting a sensor. This is a process of determining which technology or technologies best utilize the strongest differentiating traits of the changing condition while being the least affected by background and surrounding conditions. There is rarely a single solution; each technology has strengths and weaknesses that make it a good or poor choice for a given application. Ultimately, the chosen solution provides the best compromise of performance, reliability, availability and cost.

# Packaging

Refer to the indicated page number to view a specific application.

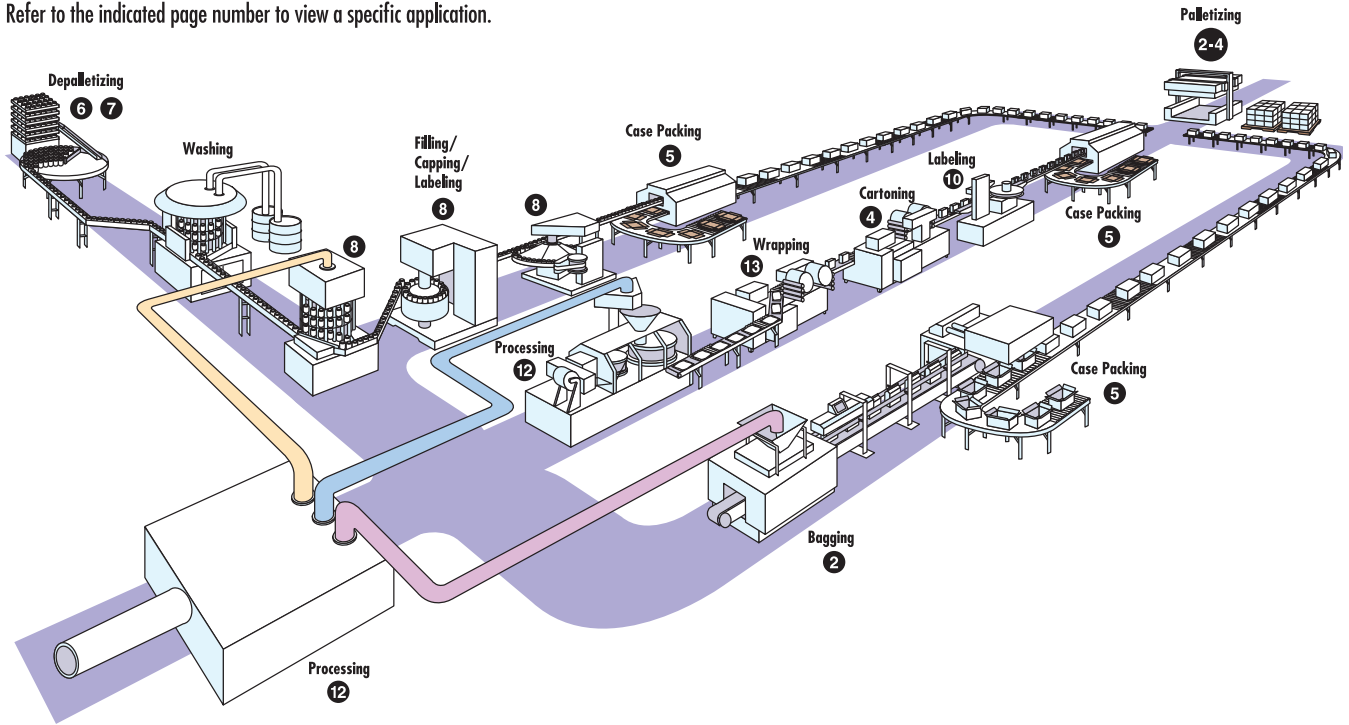

# Bagging

---

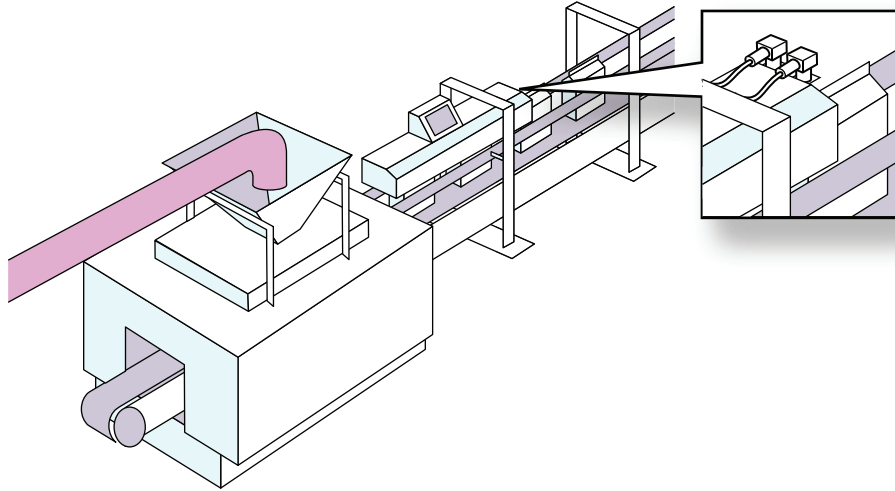

## Description of application:

Detection of sealed bags coming from a bagging machine.

## Applicable industries:

Food, Cement, Detergents

## Material(s) to be sensed:

Heavy-duty paper bags

## Environmental Conditions:

- Indoor
- Outdoor High temp
- Low temp
- High tem
- Washdown
- Heavy vibration
- Harsh chemicals
- Hazardous location
- Other \_\_\_\_\_

## Solution:

Use two (2) background suppression photoelectric sensors to verify that the bags are closed and sealed. The sensor configured in light operate mode will detect if the flap is open.

## Recommended catalog numbers and materials:

Depending on the sensing distance and accuracy, you could use two of the following background suppression sensors:

Background Suppression (2)

42EF-B1MPBE-F4\* (100 m)

42BC-B1LBAL-T4\* (1 m)

42BT-B2LBSL-F4\* (1 m)

44BSB-IJBA1-D4\* (300 mm)

\*Use 889D-F4AC-2 cordset



# Capping

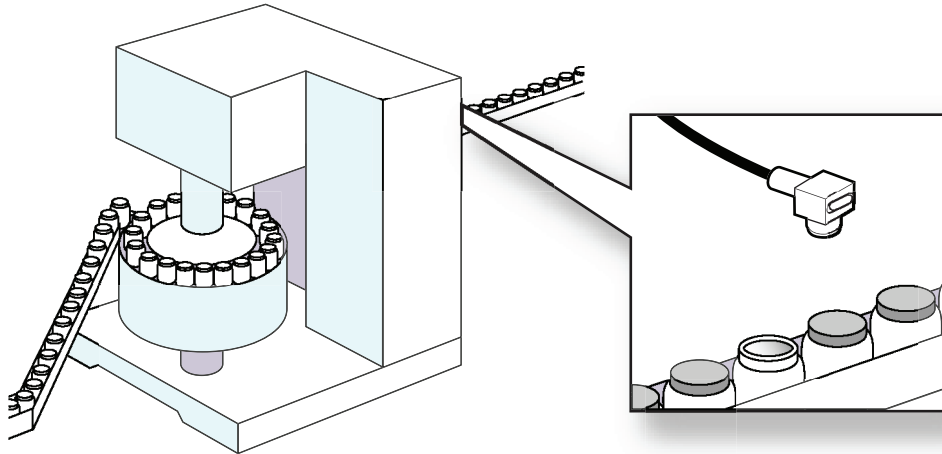

## Description of application:

To determine that a glass jar is correctly oriented and has a metallic cover on it.

## Applicable industries:

Bottling industry

## Material(s) to be sensed:

Metallic metal cover

## Environmental Conditions:

- Indoor
- Outdoor
- High tem
- Low temp
- Washdown
- Heavy vibration
- Harsh chemicals
- Hazardous location
- Other \_\_\_\_\_

## Solution:

Use a background suppression sensor to detect the glass jar's cover, adjusting the mounting bracket such that the sensor will ignore all jars without a metallic cover. The sensors output will produce a pulse train as the jars pass by. This can be monitored by a PLC. A longer pulse would indicate a missing cap.

## Recommended catalog numbers and materials:

Background Suppression

42EF-B1MPBE-F4\* (100 mm)

or

44BSB-1JBA1-D4\* (300 mm)

\*Use 889D-F4AC-2 cordset

# Cartoning

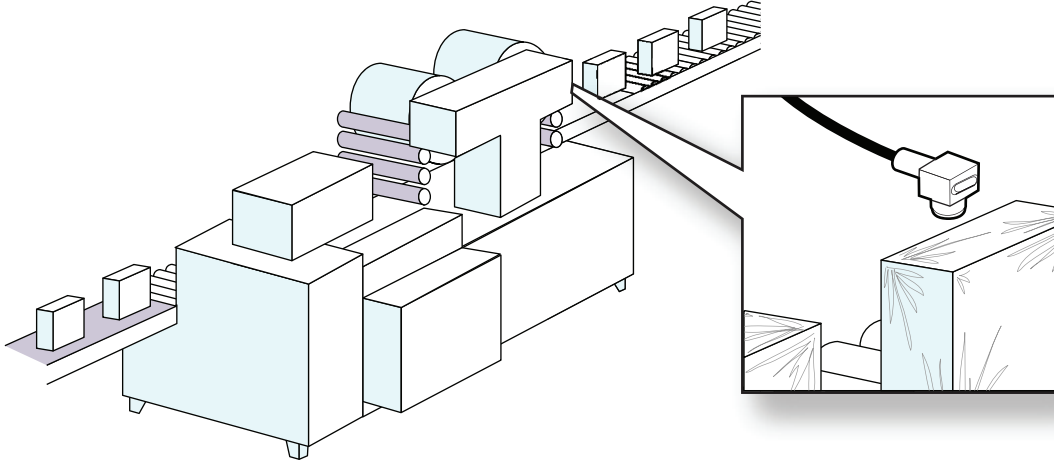

## Description of application:

To detect a cellophane wrapper on cardboard boxes.

## Applicable industries:

Food, Detergents, Automotive parts,  
Miscellaneous products packaging

## Material(s) to be sensed:

Cellophane wrapper over a cardboard box.

## Environmental Conditions:

- Indoor
- Outdoor
- High tem
- Low temp
- Washdown
- Heavy vibration
- Harsh chemicals
- Hazardous location
- Other \_\_\_\_\_

## Solution:

Use a fixed focus or fiber optic sensor and adjust the sensitivity to detect the cellophane while ignoring the cardboard box.

## Recommended catalog numbers and materials:

Fixed Focus Sensor (43 mm)

42KL-F2LBL-F4\*

or

Fiber Optic Sensor

45FPL-2LHE-Y3\*\* plus

Fiber Optic Cable

43PR-NES57ZS

\*Use 889D-F4AC-2 cordset

\*\* Use 889D-F3AB-2 cordset

# Case Packing

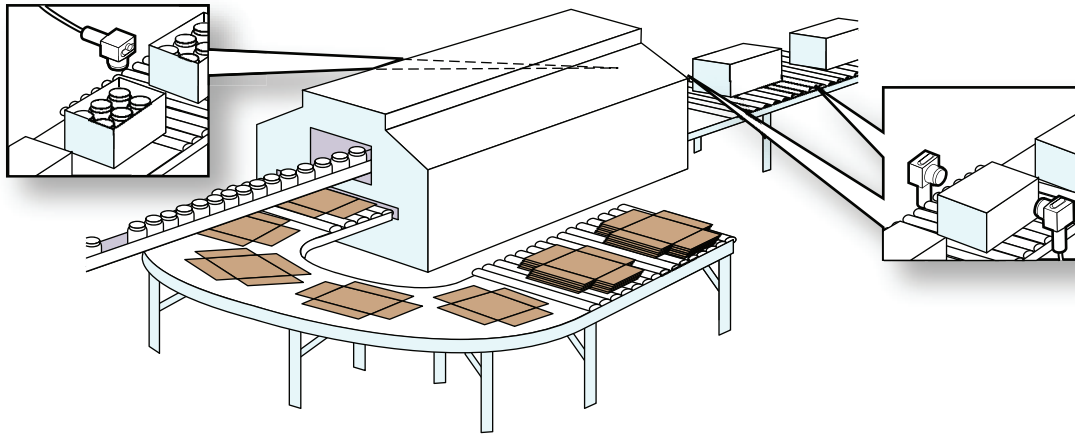

## Description of application:

To detect six (6) jars with white metallic lids inside of an open cardboard box.

## Applicable industries:

Bottling, Food industries

## Material(s) to be sensed:

White metallic lids

## Environmental conditions:

- Indoor
- Outdoor
- High temp
- Low temp
- Washdown
- Heavy vibration
- Harsh chemicals
- Hazardous location
- Other \_\_\_\_\_

## Solution:

Detect the front edge of the cardboard box with a transmitted beam sensor pair. Detect the jars with six (6) background suppression sensors (one sensor per jar). The transmitted beam pair acts as a gating sensor, letting the six background suppression sensors know when to look for caps.

## Recommended catalog numbers and materials:

Standard Solution

Background Suppression (100 mm):

(6) 42EF-B1MPBE-F4\*

Transmitted Beam Pair (4 m):

Emitter (1) 42EF-E1E2B-F4\*

Receiver (1) 42EF-R9KBBV-F4\*

Laser Models

Diffuse Mode (300 mm):

(6) 42CM-D8MPA-D4\*

Transmitted Beam Pair

(3 mm to 50 m adjustable):

Emitter: (1) 42CM-E8E2B-D4\*

Receiver: (1) 42CM-R8MPB-D4\*

\* Use 889D-F4AC-2 cordset

# Depalletizing

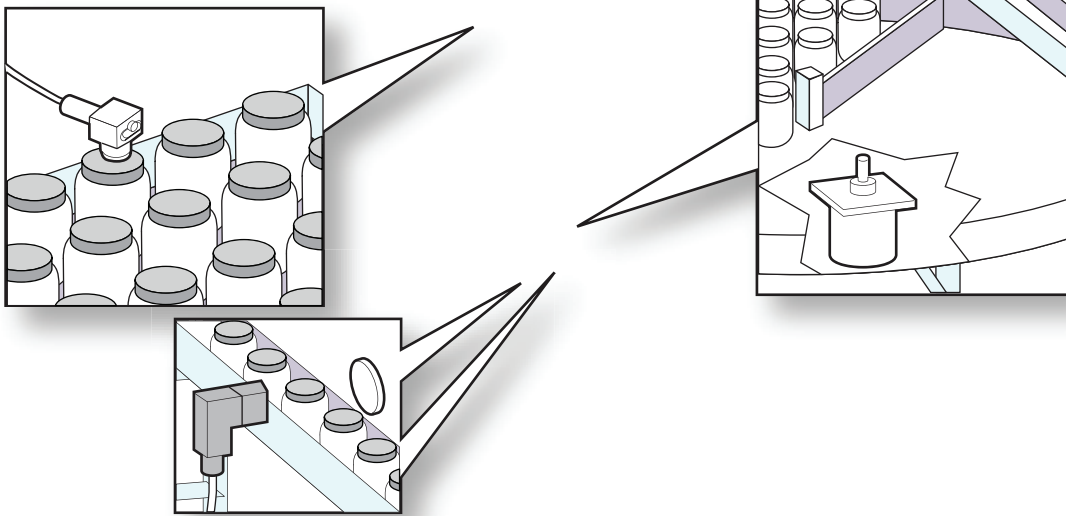

## Description of application:

Depalletize containers of clear, empty jars for the filling process.

## Applicable industries:

Packaging

## Material(s) to be sensed:

Empty jars and containers of jars

## Environmental conditions:

- Indoor
- Outdoor
- High tem
- Low temp
- Washdown
- Heavy vibration
- Harsh chemicals
- Hazardous location
- Other \_\_\_\_\_

## Solution:

A background suppression sensor is used to indicate the presence of containers of jars and elevate the jar containers to the proper position for offloading. An incremental encoder is used to provide velocity feedback for the rotary accumulation table. ClearSight 9000 is used with a stop motion detector module to control the depalletizing feed to the accumulation table. This sensor is mounted on the take-away conveyor.

## Recommended catalog numbers and materials:

Background Suppression (100 mm):

42EF-B1MPBE-F4\*

Incremental Encoder

845H-SJDZ24FWY2 with

845-CAC-100 cable

ClearSight (up to 1.2 m)

42GRC-9200-QD\*

\*Use 889-F4AC-2 cordset

## Depalletizing (2)

---

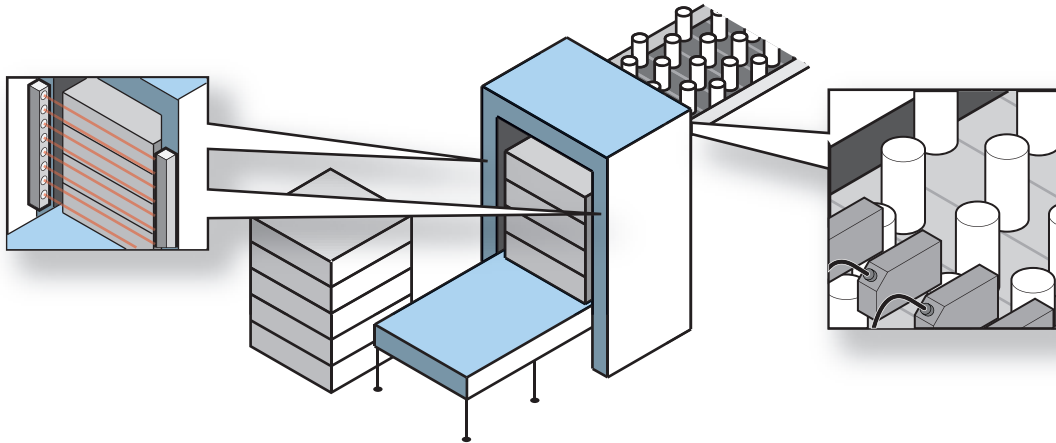

### Description of application:

Removing cases of beer from a pallet and sensing the presence of the cases on the conveyor in preparation for disassembling into six-packs.

### Applicable industries:

Bottling & brewing

### Material(s) to be sensed:

Boxed cases of beer

### Environmental conditions:

- Indoor
- Outdoor
- High tem
- Low temp
- Washdown
- Heavy vibration
- Harsh chemicals
- Hazardous location
- Other \_\_\_\_\_

### Solution:

Mounting a transmitted beam RightSight photoelectric sensor on the conveyor to detect cases of beer. Then, using background suppression units, six (6) bottles can be counted by sensing their caps and subsequently placed into the six-pack holders.

### Recommended catalog numbers and materials:

Transmitted Beam Pair

Emitter: (1) 42EF-E1EZB-F4\*

Receiver: (1) 42EF-R9KBBV-F4\*

Background Suppression

42EF-B1MPBE-F4\*

\*Use 889D-F4AC-2 cordset



# Filling

---

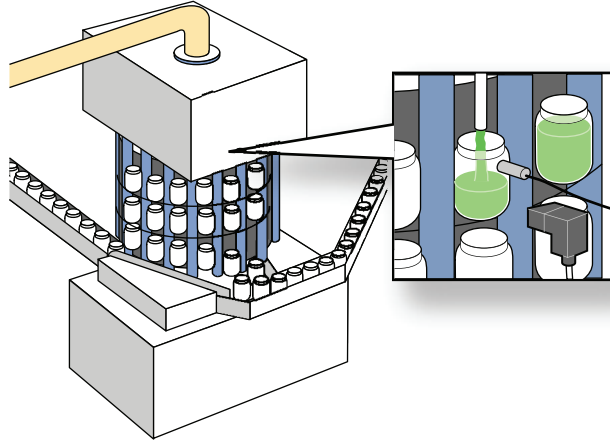

## Description of application:

Filling Bottles

## Applicable Industries:

Bottling & brewing

## Material(s) to be sensed:

Beer, Water, Soda

## Environmental conditions:

- Indoor
- Outdoor
- High tem
- Low temp
- Washdown
- Heavy vibration
- Harsh chemicals
- Hazardous location
- Other \_\_\_\_\_

## Solution:

Sensing the presence of the bottle can be achieved through the use of a clear object detector such as ClearSight. A capacitive proximity sensor used at the filling station ensures the glass beer bottles are filled to the designated "Fill Level" every time. The advantage of using the capacitive proximity sensor is that it will ignore the glass while sensing the presence of the beer.

## Recommended catalog number and materials:

ClearSight

42GRC-9200-QD\*

Capacitive Proximity Sensor

875CP-D8NP18-A2

\*Use 889D-F4AC-2 Cordset

# Filling/Lidding/Capping

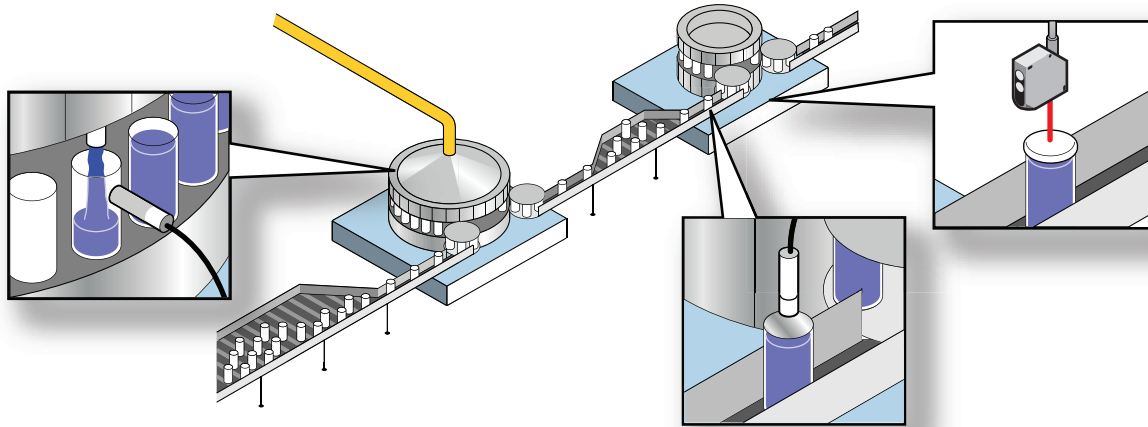

## Description of application:

1. Detection of fill levels in nonmetallic containers.
2. Confirm presence of aluminum foil and cap/lid on the container.
3. Check filler nozzle after filling to be sure it has not fallen in the filled bottle.

## Applicable Industries:

Food and Beverage, Packaging, Paint

## Material(s) to be sensed:

Various liquid materials packaged in plastic containers.

## Environmental conditions:

- Indoor
- Outdoor
- High tem
- Low temp
- Washdown
- Heavy vibration
- Harsh chemicals
- Hazardous location
- Other \_\_\_\_\_

## Solution:

1. Fill level: 30 mm capacitive sensor mounted about 2 mm from container.
- 2a. Aluminum foil: 18 mm proximity sensor to sense the foil through the plastic cap.
- 2b. Lid/cap placement: background suppression photoelectric sensor.
3. Filler nozzle presence: Use optical fork sensor to confirm filler nozzle presence, count and compare to known quantity of filler nozzles per rotation to confirm that none have fallen in a filled bottle.

## Recommended catalog numbers and materials:

Capacitive Proximity Sensor

875CP-D20NP30-D4\*

Inductive Proximity Sensor

871TM-DH8CP18-D4\*

RightSight Background Suppression Sensor

42EF-B1MPBE-F4\*

Optical Fork Sensor

45LSP-2LPA2-P3 with

889P-F3AB-2 cordset

\*Use 889D-F4AC-2 cordset

# Labeling

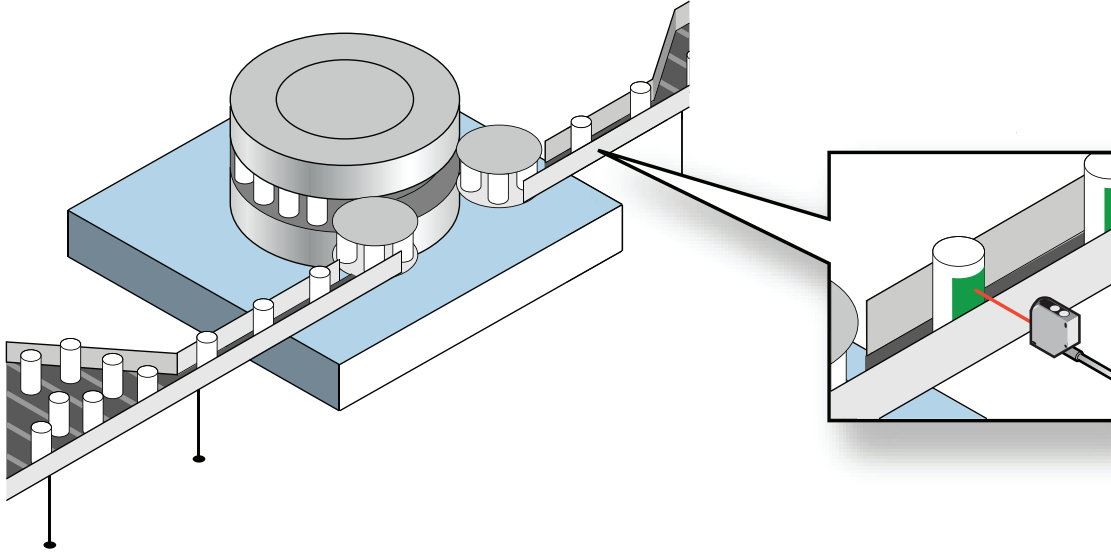

## Description of application:

To confirm the presence of a label on a glass jar by detecting a wide colored line around the bottom of the label.

## Applicable industries:

Food & Beverage industries

## Material(s) to be sensed:

Paper labels on glass jars

## Environmental conditions:

- Indoor
- Outdoor
- High tem
- Low temp
- Washdown
- Heavy vibration
- Harsh chemicals
- Hazardous location
- Other \_\_\_\_\_

## Solution:

Use a 45CLR ColorSight photoelectric sensor to detect the color band on the label. Each sensor can be taught to detect 3 colors (3 outputs) and also allows adjustment of the color tolerance.

## Recommended catalog numbers and materials:

ColorSight (32 mm)

45CLR-5JPC1-D8\*

\*Use 889D-F8AB-2 cordset

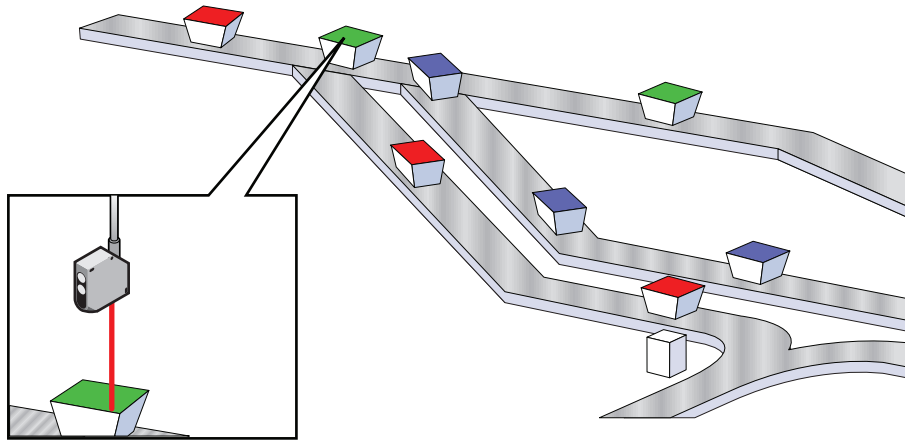
**Description of application:**

To sort yogurt containers (strawberry, blueberry and lime) based on the color of the cap.

**Applicable industries:**

Food packaging

**Material(s) to be sensed:**

Plastic, Foil

**Environmental conditions:**

- Indoor
- Outdoor
- High tem
- Low temp
- Washdown
- Heavy vibration
- Harsh chemicals
- Hazardous location
- Other \_\_\_\_\_

**Solution:**

A single 45CLR color sensor can be used to detect up to 3 colors. Dependent on the color matched 1 of the (3) color sensors outputs will then transition. The containers are then sorted according to the color of the lids.

**Recommended catalog numbers and materials:**

ColorSight

(3) 45CLR-5JPC1-D8\*

\* Use (3) 889D-F8AB-2 cordsets

# Processing

---

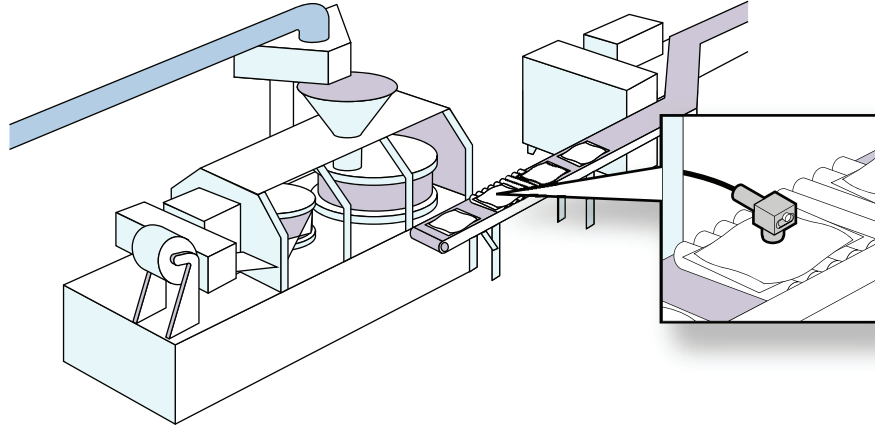

**Description of application:**

Detect presence of a substance on a pan.

**Applicable industries:**

Food

**Material(s) to be sensed:**

Ingredient mixture

**Environmental conditions:**

- Indoor
- Outdoor
- High tem
- Low temp
- Washdown
- Heavy vibration
- Harsh chemicals
- Hazardous location
- Other \_\_\_\_\_

**Solution:**

Use two background suppression type photoelectric sensors to monitor ingredient level on a pan.

The first sensor should be positioned so that the sensing range is just above the desired substance level and that the second sensor is positioned with the sensing range just below the desired level. As long as the first sensor is OFF and the second sensor is ON the substance is at the right level. If it is too thick, both turn ON; too thin, both turn OFF.

**Recommended catalog numbers and materials:**

Background Suppression  
(2) 42EF-B1MPBE-F4\*

\*Use 889D-F4AC-2 cordset



# Wrapping

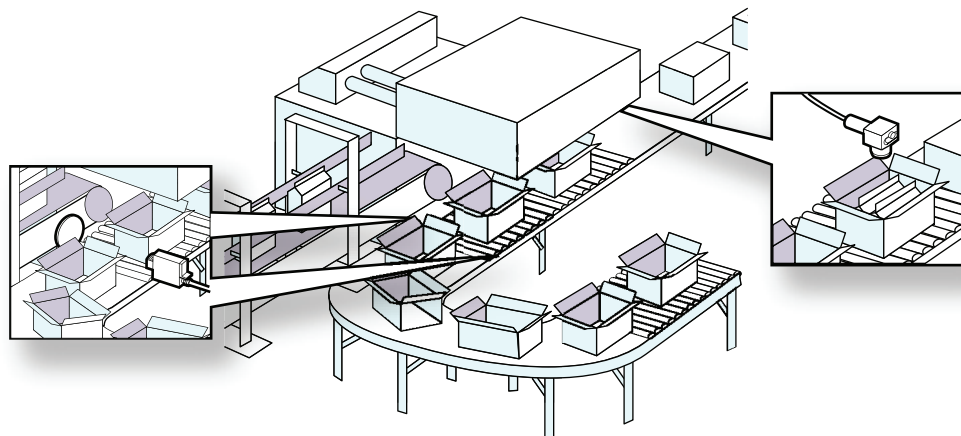

## Description of application:

Sense presence of corrugated box and baking flour so that the box can be plastic wrapped.

## Applicable industries:

Food, Packaging

Material(s) to be sensed:

1. Corrugated box
2. White baking flour

## Environmental conditions:

- Indoor
- Outdoor
- High tem
- Low temp
- Washdown
- Heavy vibration
- Harsh chemicals
- Hazardous location
- Other \_\_\_\_\_

## Solution:

Use retroreflective photoelectric sensor to detect the leading edge of the box so that the box is positioned correctly for the insertion of the flour, then confirm the presence of the flour using a background suppression sensor. Once this is done, the box is sealed and plastic wrapped.

## Recommended catalog numbers and materials:

Retroreflective Photoelectric Sensor

42KL-UL2LBF4\* (5 m)

Reflector: 92 – 39

Background Suppression Sensor

42EF-B1MPBE-F4\* (100 mm)

Polarized Retroreflective Sensor

42JS-PZMPA2-F4\* (3.5 m)

Retroreflective Sensor

42CA-U2MPA-D4\* (7.2 m)

\*Use 889D-F4AC-2 cordset

**Note:** Flour and similar materials can be flammable. The use of X-proof or intrinsically safe sensors is required when hazardous or flammable materials are present.

# Material Handling

Refer to the indicated page number to view a specific application.

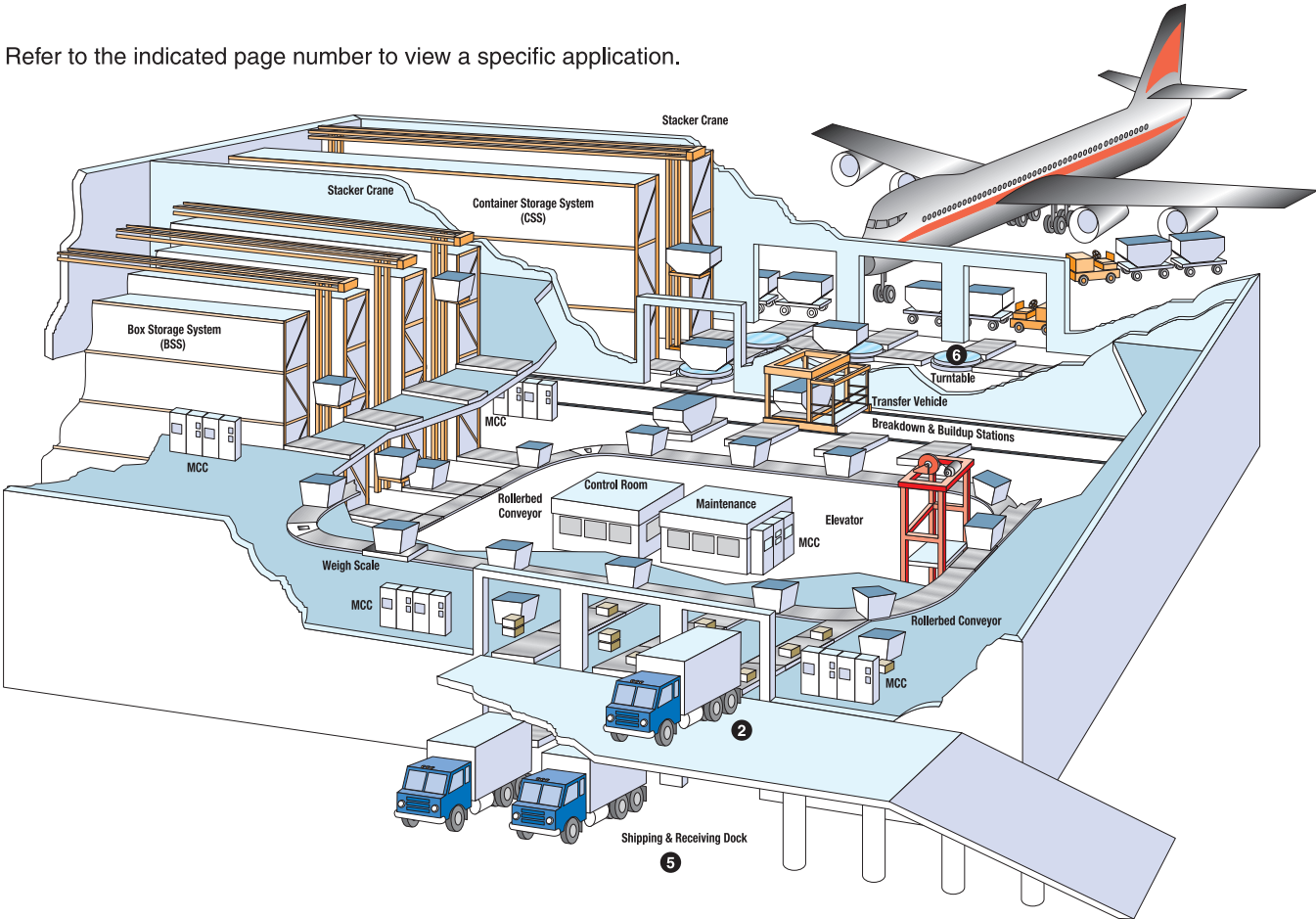

# Extendable Shipping Conveyors

---

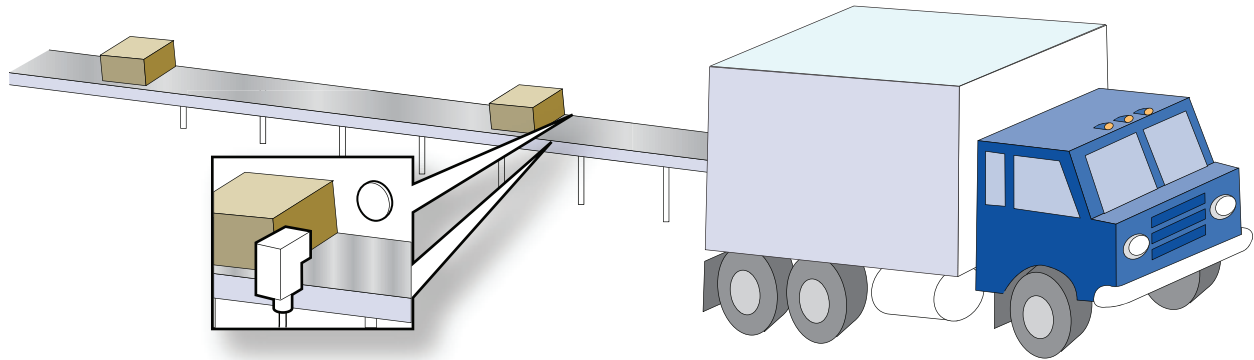

## Description of application:

Loading (and counting) of boxes.

## Applicable industries:

Shipping, Food warehouses, Appliance warehouses

## Material(s) to be sensed:

Boxes and other various materials being loaded on or unloaded from trucks or conveyors. Counting the packages may also be a part of this process.

## Environmental conditions:

- Indoor
- Outdoor
- High tem
- Low temp
- Washdown
- Heavy vibration
- Harsh chemicals
- Hazardous location
- Other \_\_\_\_\_

## Solution:

Polarized retroreflective photoelectric sensor.

## Recommended catalog numbers and materials:

RightSight Polarized Retroreflective Photoelectric Sensor (3 m)

42EF-P2MPB-F4\*

VisiSight (3.5 m)

42JS-P2MPA2-F4\*

\*Use 889D-F4AC-2 cordset

# Automatic Palletizer

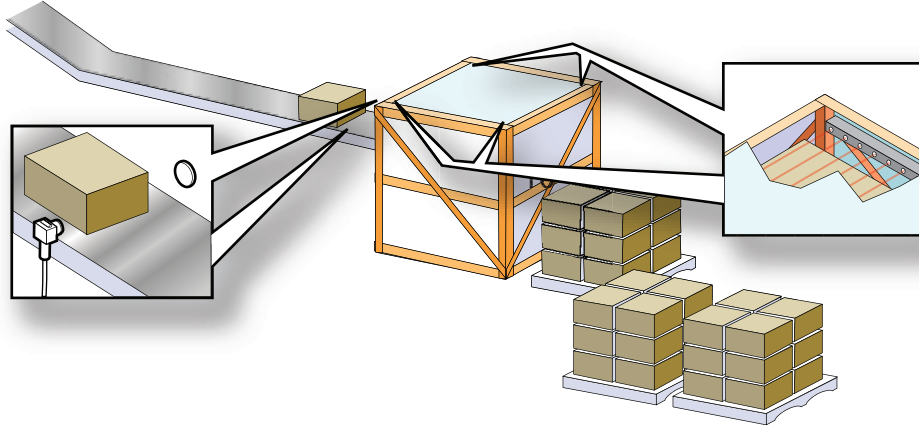

## Description of application:

Sense correct number of packages on a pallet before its wrapping and removal.

## Applicable industries:

Food

## Material(s) to be sensed:

Cardboard boxes

## Environmental conditions:

- Indoor
- Outdoor
- High temp
- Low temp
- Washdown
- Heavy vibration
- Harsh chemicals
- Hazardous location
- Other \_\_\_\_\_

## Solution:

Use polarized retroreflective photoelectric sensor to count boxes entering palletizer. Initiate table movement and indicate when pallets are full.

Use 45MLA for height detection and prevention of pallet overhang.

## Recommended catalog number and materials

Polarized Retroreflective Sensor

42JS-P2MPB1-F4\*

Measuring Light Arrays

45MLA-CTRL-ALG

45MLA-ARRAYS see catalog for part numbers, example 45MLA-AT0900P10 with 445L-AC8RJ3 connection cables

\*Use 889D-F4AC-2 cordset

# Palletizing

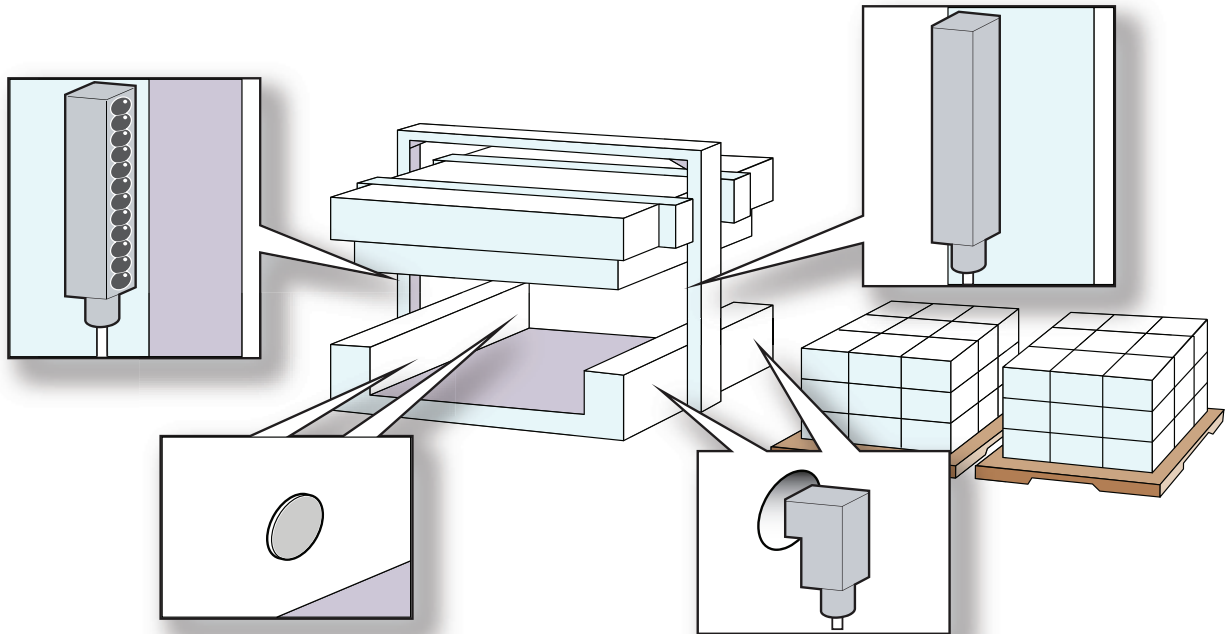

## Description of application:

Packages are to be stacked 3 high on wooden pallets.

## Applicable industries:

Material handling, Packaging

## Material(s) to be sensed:

Wooden pallets and cardboard boxes

## Environmental conditions:

- Indoor
- Outdoor
- High tem
- Low temp
- Washdown
- Heavy vibration
- Harsh chemicals
- Hazardous location
- Other \_\_\_\_\_

## Solution:

Two polarized retroreflective sensors are mounted in the palletizing station to position the empty pallet. The space between these sensors is 4 inches less than the length of the pallet.

Use 45MLA Arrays along with 45MLA discrete controller. The arrays can be configured to control height via discreet outputs. May also be used for overhang detection.

## Recommended catalog and material numbers:

Consult Sensor Catalog for array options and cable lengths. 45MLA-CTRL\*

\*Serial communications options also available.



# Receiving Docks

---

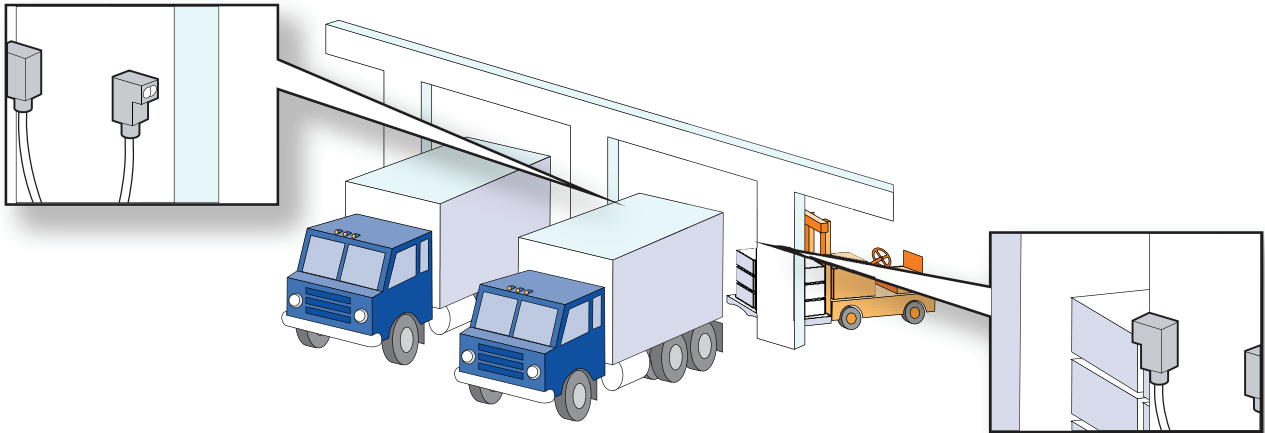

**Description of application:**

Sense presence of trucks at dock doors.

**Applicable industries:**

Warehouse

**Material(s) to be sensed:**

Truck boxes

**Environmental conditions:**

- Indoor
- Outdoor
- High temp
- Low temp
- Washdown
- Heavy vibration
- Harsh chemicals
- Hazardous location
- Other \_\_\_\_\_

**Solution:**

Position transmitted beam photoelectric sensors at truck box height, so as not to detect a person, at dock doors.

**Recommended catalog numbers and materials:**

Transmitted Beam Pair

Emitter: 42GRR-9002-QD\*

Receiver: 42GRL-9000-QD\*

Heavy duty impact bracket

60-2725

\*Use 889D-F4AC-2 cordset

# Turntable

---

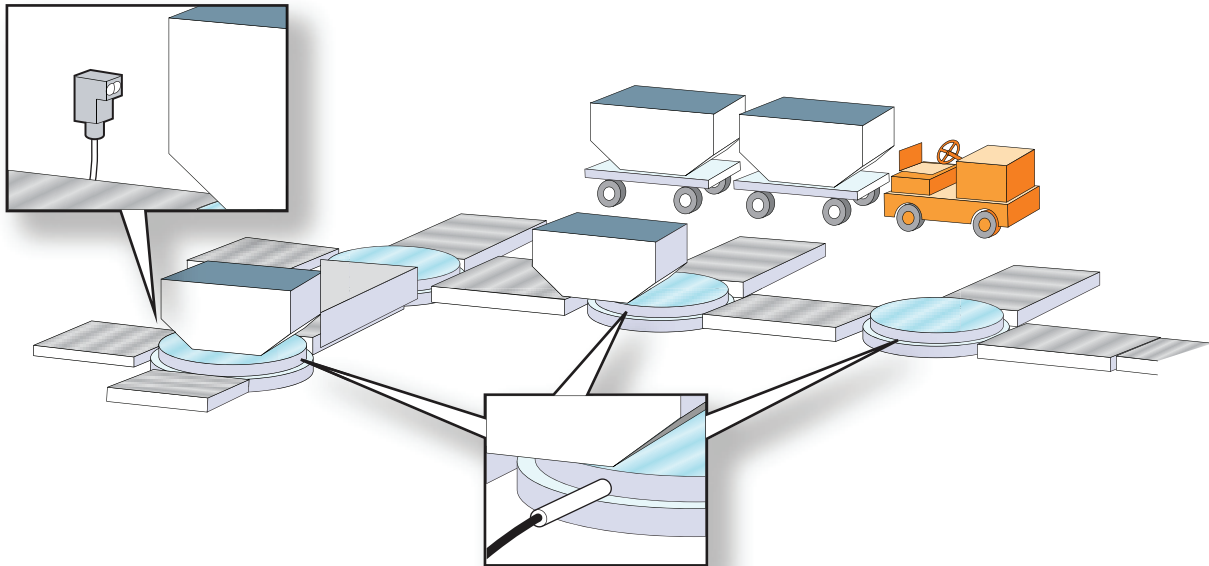

## Description of application:

Sense container presence and position of the turntable.

## Applicable industries:

Airline

## Material(s) to be sensed:

Shipping containers

## Environmental conditions:

- Indoor
- Outdoor
- High temp
- Low temp
- Washdown
- Heavy vibration
- Harsh chemicals
- Hazardous location
- Other \_\_\_\_\_

## Solution:

Use inductive proximity sensors for turntable positioning and photoelectric sensor for container detection.

## Recommended catalog numbers and materials:

Stainless Steel Inductive Proximity Sensor  
871TM-B15N30-N3\*

Photoelectric Sensor  
42GRP-9040-QD1\*

\*Use 898N-F4AF-6F – 4 pin MiniQD

**Note:** Additionally, consider implementing an RFID system to track and trace the container contents and its location.

# Automotive

Go to the indicated page number to view a specific application

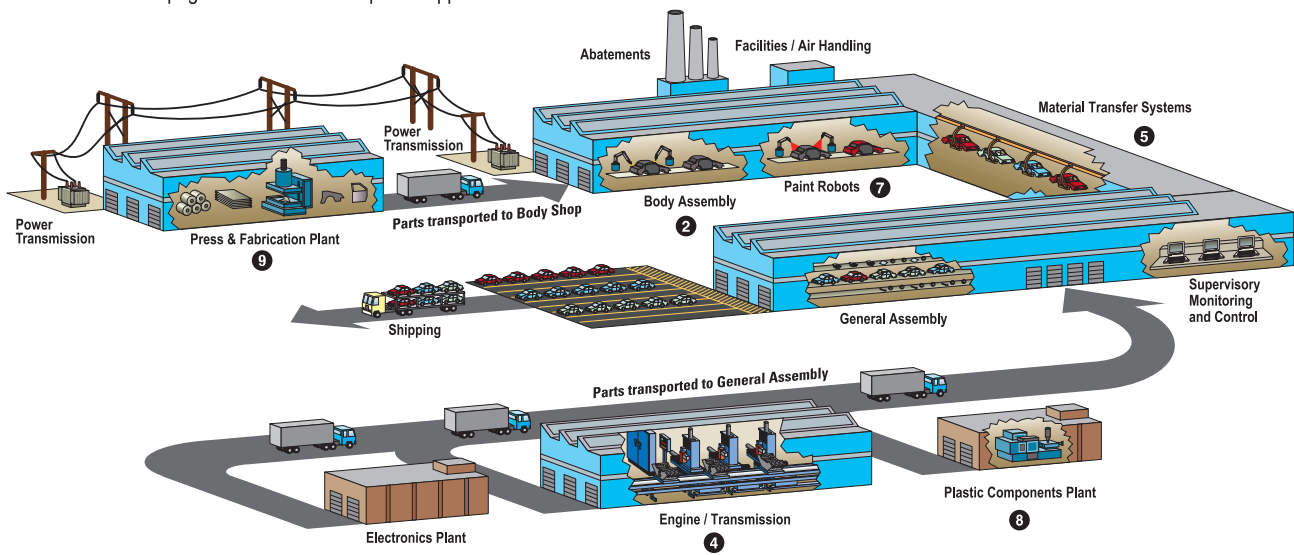

# Body Assembly

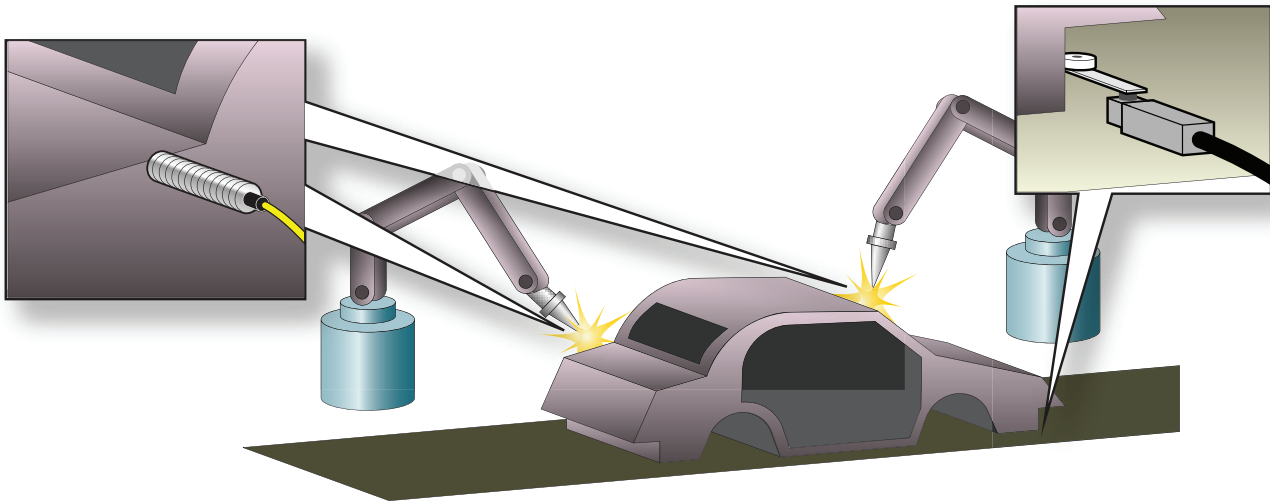

## Description of application:

Monitor the position of the car body in order for robots to assemble vehicle components at different assembly stations.

## Applicable industries:

Automotive

## Material(s) to be sensed:

Metal and plastic

## Environmental conditions:

- Indoor
- Outdoor
- High temp
- Low temp
- Washdown
- Heavy vibration
- Harsh chemicals
- Hazardous location
- Other: Presence of electromagnetic fields and weld slag.

## Solution:

Various sensors can be mounted at different locations to precisely position the car body and allow robotic arms to perform welding operations as well as install different interior and exterior components, e.g., seats, windshields, doors, axles, etc.

## Recommended catalog numbers and materials:

For welding locations use our weld field immune:

Cylindrical Proximity Sensor

871ZC-DW5NP18-D4\*

or

VersaCube Proximity Sensor

871P-DW20NP40-D4\*

\* Use 889D-F4WE-2 ToughLink MicorQD cable

**Note:** For other locations, use 802T-AP or 802T-AY5 limit switches with 802T-W2R rubber roller lever.

# E-Coat Tanks

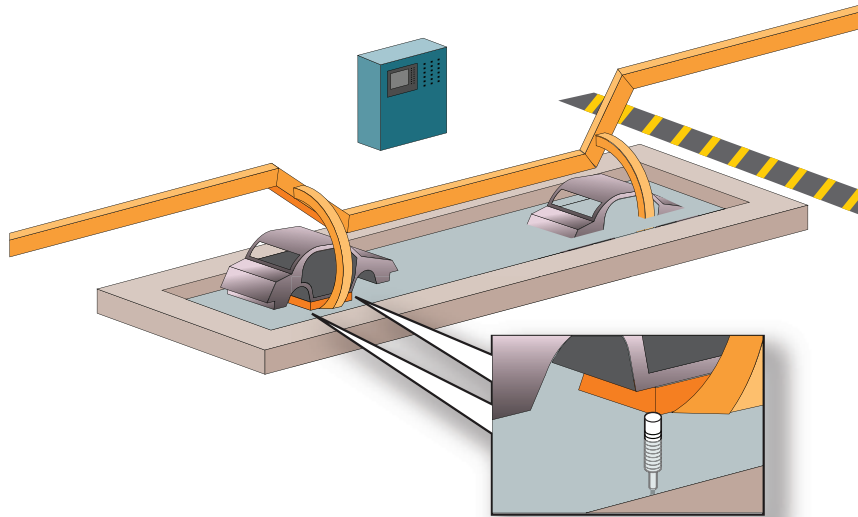

## Description of application:

Ensure that an automobile frame is positioned correctly on the rack for the submersion process, which will apply an initial exterior coat of paint.

## Applicable industries:

Automotive

## Material(s) to be sensed:

Two specific positions on the undercarriage of the metal frame.

## Environmental conditions:

- Indoor
- Outdoor
- High temp
- Low temp
- Washdown
- Heavy vibration
- Harsh chemicals
- Hazardous location
- Other \_\_\_\_\_

## Solution:

Place (2) inductive proximity sensors in two specific positions on the automobile frame. These sensors will be sensed to create an “AND GATE” and will send a signal to the PLC, which will start the submersion process.

## Recommended catalog numbers and materials:

### Inductive Proximity Sensors

(2) 871TM 3-Wire Submersible Proximity Sensor (For example: 871TM-DX14). Also consider using the following switch to monitor tank level.

### Solid-State Level Switch

840E-TB1B2A1D4\*

\*Use 889D-F4AC-2 micro cordset

# Engine Transmission

---

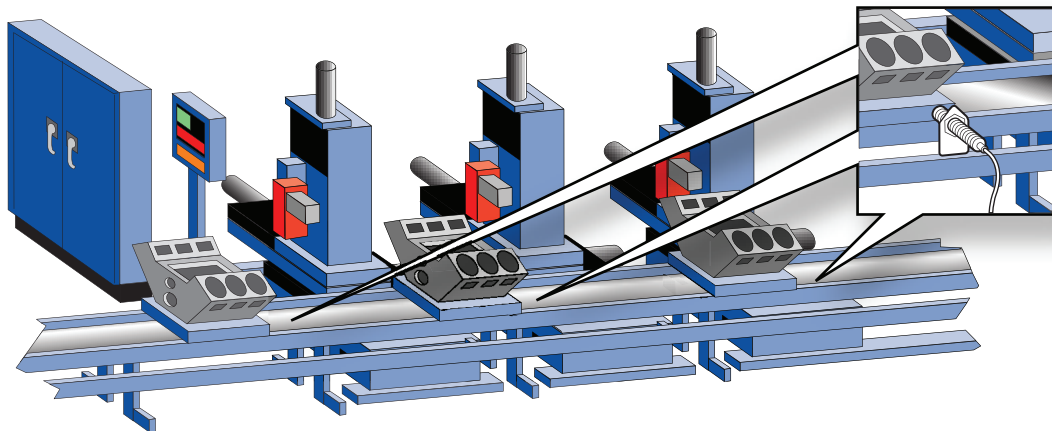

## Description of application:

To detect the presence of an engine block at each work station.

## Applicable industries:

Automotive industry

## Material(s) to be sensed:

Metal engine blocks

## Environmental conditions:

- Indoor
- Outdoor
- High temp
- Low temp
- Washdown
- Heavy vibration
- Harsh chemicals
- Hazardous location
- Other Presence of nonferrous shavings

## Solution:

Use three (3) inductive proximity sensors to detect an engine block skid at each station.

## Recommended catalog numbers and materials:

Inductive Proximity Sensors

(3) 871TM-DF3NP18-D4\*  
(18 mm ferrous only metal  
face inductive sensor

\*Use (3) 8890-F4AC-2 (2 m MicroQD cable)

To track build data of engine blocks as they pass through the manufacturing process, use 56RF RFID system.

# Material Transfer System

---

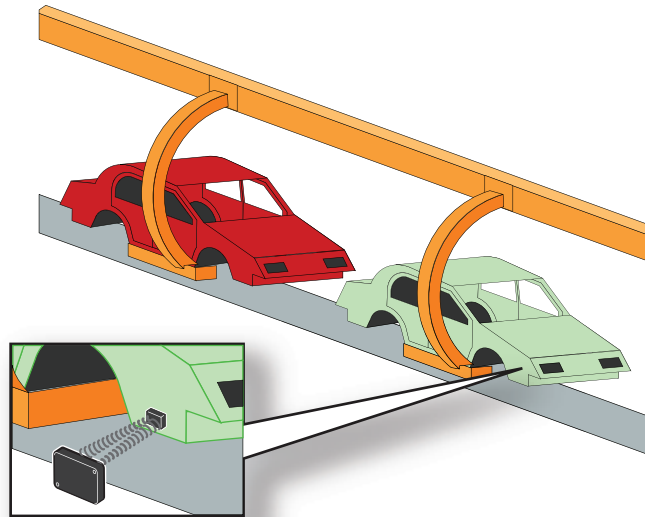

## Description of application:

Sensing parts to transfer to specifically designated areas.

## Applicable industries:

Automotive, packaging and manufacturing.

## Material(s) to be sensed:

Metal parts or containers

## Environmental conditions:

- Indoor
- Outdoor
- High temp
- Low temp
- Washdown
- Heavy vibration
- Harsh chemicals
- Hazardous location
- Other \_\_\_\_\_

## Solution:

Products can be sensed by RFID. The product can then be transported to the required area.

Use 56 RFID system to monitor/direct product to the correct manufacturing locations.

# Oven

---

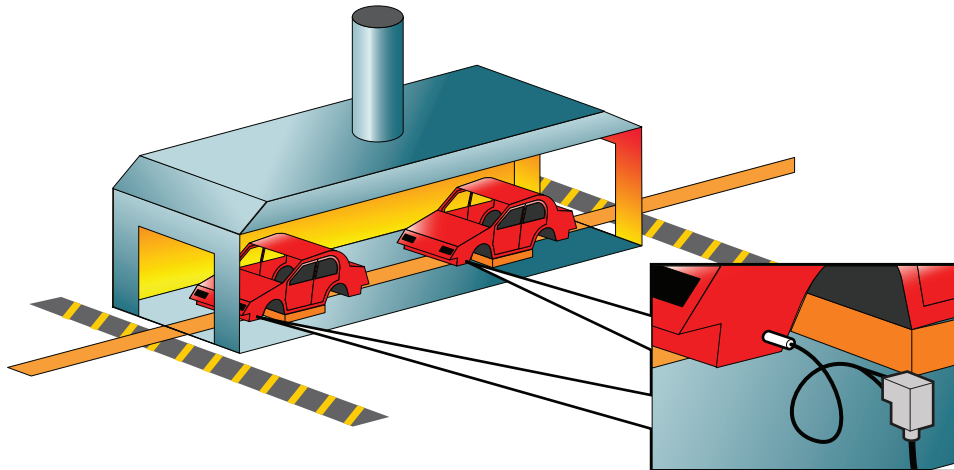

## Description of application:

Sense that automobile bodies are in position for finish curing.

## Applicable industries:

Automotive, Appliance

## Material(s) to be sensed:

Metal or plastic automobile body part.

## Environmental conditions:

- Indoor
- Outdoor
- High temp
- Low temp
- Washdown
- Heavy vibration
- Harsh chemicals
- Hazardous location
- Other \_\_\_\_\_

## Solution:

Due to high temperature a glass fiber optic sensor would be a solution.

## Recommended catalog numbers and materials:

Fiber optic sensor and transmitted beam glass fiber. Fiber optic cable type and size would be selected according to customer preference.

Fiber Optic Sensor

42EF-G1MPA-F4

Fiber Optic Cables

(2) 43GT-TBB25SL  
(up to 500 Degrees)

(2x)43GT-TBB25FL  
(up to 900 Degrees  
continuous temperature)



# Paint Robots

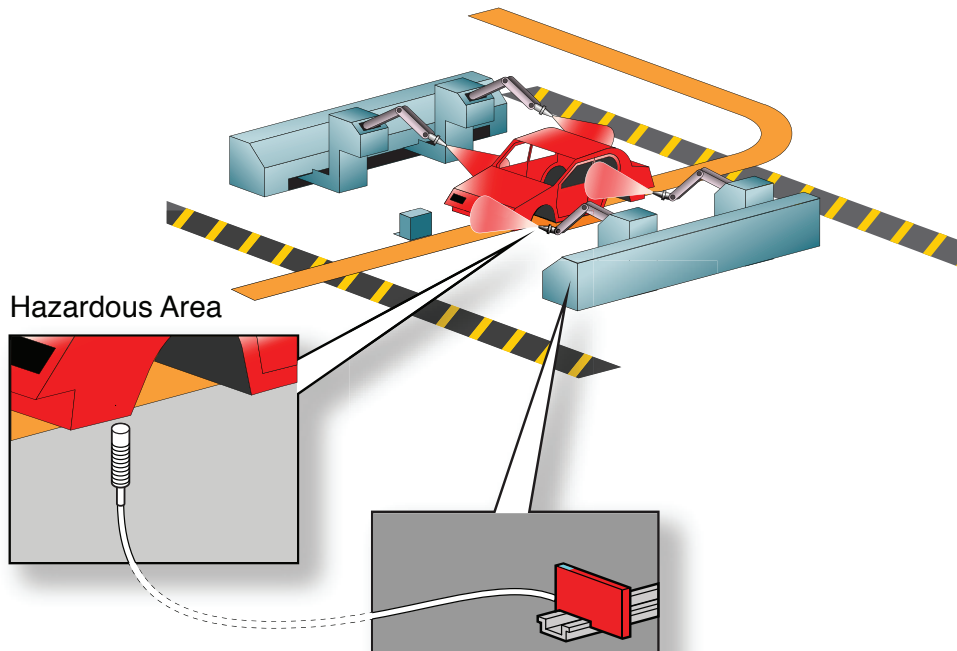

## Description of application:

Sense that the automobile body is in the proper position for painting. Sensors may be washed down with chemicals during periodic maintenance.

## Applicable industries:

Automotive, Appliance, Machine

## Material(s) to be sensed:

Metal

## Environmental conditions:

- Indoor
- Outdoor
- High temp
- Low temp
- Washdown
- Heavy vibration
- Harsh chemicals
- Hazardous location

Other \_\_\_\_\_

## Solution:

Sense that the body is in position to be painted by using an intrinsically safe proximity sensor. The proximity sensor will not have problems with paint build up.

## Recommended catalog numbers and materials:

871TM-DR intrinsically safe proximity sensor with 897H-S intrinsically safe zener diode barriers.

RFID tags can be programmed with car body / panel / color data. This data can then be read as the car enters the spray booth, spray robots can then correctly profile the part, reducing over spray and paint usage.

# Plastic Components Plant

---

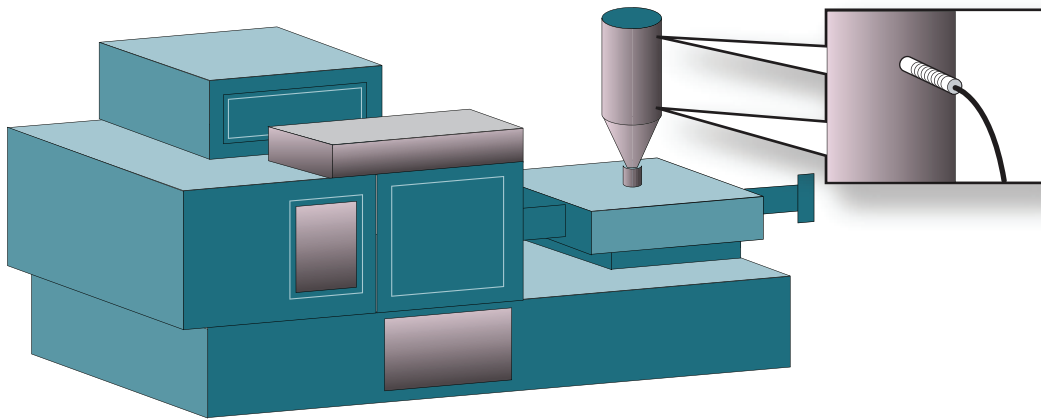

**Description of application:**

Sensing level of plastic pellets in hopper.

**Applicable industries:**

Injection molding

**Material(s) to be sensed:**

Plastic

**Environmental conditions:**

- Indoor
- Outdoor
- High temp
- Low temp
- Washdown
- Heavy vibration
- Harsh chemicals
- Hazardous location
- Other \_\_\_\_\_

**Solution:**

Place a capacitive sensor in the wall of the hopper to sense the level of the pellets. Either high, low or both levels can be monitored.

**Recommended catalog numbers and materials:**

Capacitive Sensor (5-20 mm)

875C-N20NP30-D4\* 30 mm threaded

\*Use 889D-F4AC-2 cordset

## Press & Fabrication Plant

---

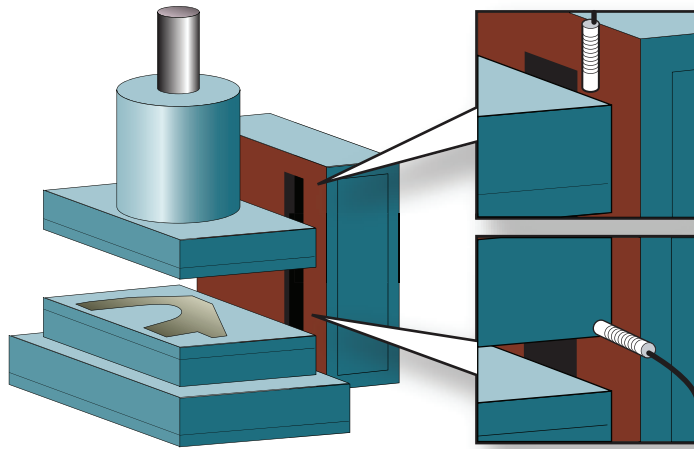

### Description of application:

Sense the position of the ram press. Safety issues might include two-hand control and pinch point.

### Applicable industries:

Machine tool, Automotive, Manufacturing

### Material(s) to be sensed:

Metal

### Environmental conditions:

- Indoor
- Outdoor
- High temp
- Low temp
- Washdown
- Heavy vibration
- Harsh chemicals
- Hazardous locations
- Other \_\_\_\_\_

### Solutions:

Sense the home and down positions of the ram using limit switches or proximity switches. A point of operation light curtain could be used to prevent injury. Two hand control to keep the operators hands out of the press during stamping cycle.

### Recommended catalog numbers and materials:

871TM or 872C series proximity switch or 802T, 802M limit switches. 440L light curtains, 800Z touch buttons and MSR 12S safety relay: 440R-D23171.

For car body positions use 871TM  
Prior to paint application use 45MLA light array to control paint application and reduce excess overspray and eliminate waste.

**Note:** Proximity or limit switches not specifically marked as safety components should not be used in safety applications.

# Spray Reciprocators

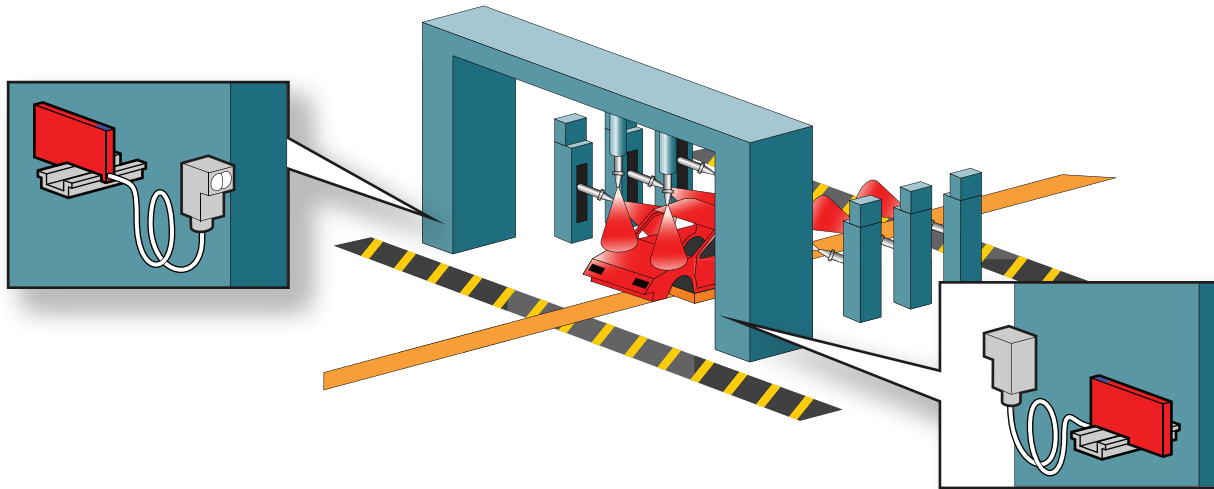

## Description of applications:

To activate spray paint nozzle when the object/area to be painted is in the proper position.

## Applicable industries:

Paint spray booths

## Material(s) to be sensed:

Metal, Plastic

## Environmental conditions:

- Indoor
- Outdoor
- High temp
- Low temp
- Washdown
- Heavy vibration
- Harsh chemicals
- Hazardous location
- Other \_\_\_\_\_

## Solution:

Using an intrinsically safe transmitted beam sensor to confirm the presence of the target and operate the spray nozzles only when the body is in the spray location.

## Recommended catalog numbers and materials:

Large targets: Intrinsically safe transmitted beam Series 9000 (42GRL-9540/42GRR-9500) with 897H Intrinsic Safety Barrier

## Notes:

- Paint buildup will cause false actuation unless both transmitter and receiver are adequately protected.
- With transmitted beam sensors the target does not have to be large, as long as it interrupts the beam (about 1" by 1").

# Glossary

---

**AND gate** A circuit in which two or more inputs wired in series must be closed to energize the output.

**background suppression sensing** A diffuse photoelectric sensing mode with a defined range limit, used in areas where a reflective background is close to the targets.

**dark operate mode (D.O. or D/O)** The program mode of a photoelectric sensor in which the output circuit energizes (or delay period begins) when light intensity on the photodetector has sufficiently decreased below the threshold of the photodetector.

**diffuse sensing mode** A photoelectric proximity sensing mode in which the light from the emitter strikes a surface of an object at some arbitrary angle and is detected when the receiver captures some small percentage of the diffused light that's reflected back. Also called the "direct reflection mode" or the photoelectric "proximity mode."

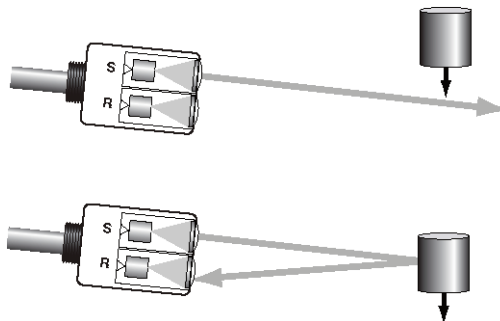

**fiber optics** Transparent fibers of glass or plastic used for conducting and guiding light energy. Used in photoelectrics as "light pipes" to conduct sensing light into and out of a sensing area.

**intrinsic safety** A design technique applied to electrical equipment (sensors and switches) and wiring for hazardous locations. The technique involves limiting electrical and thermal energy to a level below that required to ignite a specific hazardous atmosphere.

---

**intrinsic safety barrier**

A protective component designed to limit the voltage and current in a hazardous area. The barrier functions outside of the hazardous location to divert abnormal energy to ground.

**light operate mode (L.O. or L/O)**

The program mode for a photoelectric sensor in which the output energizes (or delay period begins) when the light intensity on the photodetector has sufficiently increased above the threshold of the photodetector.

**polarized retroreflective sensor**

A retroreflective mode photoelectric sensor that employs polarizing filters. As a result, the sensor can “see” the light bounced off the associated reflector without seeing the light reflected from other reflective surfaces.

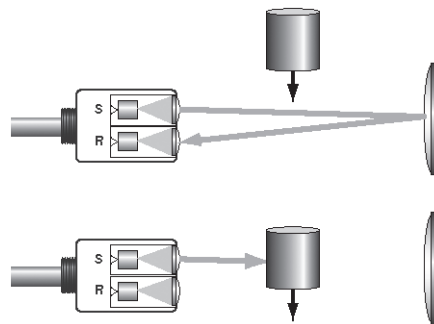

**retroreflective sensing mode**

A sensor, containing emitter and receiver, that establishes a light beam between a reflector and itself. An object is “sensed” when it interrupts this beam.

---

**sensitivity adjustment**

An adjustment that determines the sensor's ability to discriminate between different levels of light or ultrasonic waves. Sometimes called the "gain adjustment."

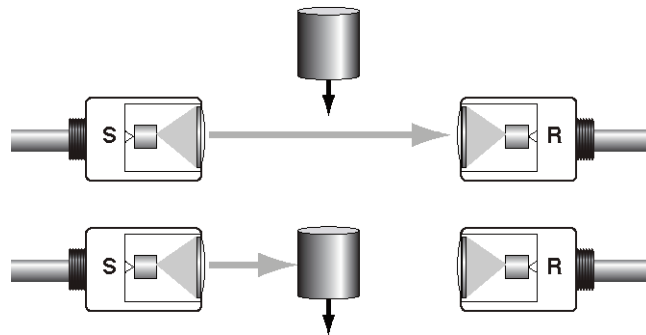

**transmitted beam**

A photoelectric sensing mode in which the sender (emitter) and receiver are positioned opposite each other so the light from the emitter shines directly at the receiver. An object then breaks the light beam established between the two.

**zener diode barrier**

An intrinsic safety barrier that uses zener diodes to prevent abnormal energy from reaching the hazardous area.



Rockwell Automation® offers a breadth of quality Allen-Bradley® components to fit your specific needs. In order to assist you with your component selection, we offer a variety of configuration and selection tools.



#### Local Distributor

Call 1.800.223.3354 to contact your local Distributor today.

<http://www.rockwellautomation.com/distributor/>



#### On-Line Product Directory

Our extensive product portfolio is designed to improve your processes through every stage of your manufacturing cycle.

<http://www.rockwellautomation.com/products/>



#### Product Selection Toolbox

Our powerful range of product selection and system configuration tools assist you in choosing and applying our products.

<http://www.rockwellautomation.com/en/e-tools/>



#### Sensors Catalog

Within this catalog you'll find an extensive selection of your Allen-Bradley sensing products.

<http://www.ab.com/catalogs/>

[www.rockwellautomation.com](http://www.rockwellautomation.com)

#### Power, Control and Information Solutions Headquarters

Americas: Rockwell Automation, 1201 South Second Street, Milwaukee, WI 53204-2496 USA, Tel: (1) 414.382.2000, Fax: (1) 414.382.4444

Europe/Middle East/Africa: Rockwell Automation NV, Pegasus Park, De Kleetlaan 12a, 1831 Diegem, Belgium, Tel: (32) 2 663 0600, Fax: (32) 2 663 0640

Asia Pacific: Rockwell Automation, Level 14, Core F, Cyberport 3, 100 Cyberport Road, Hong Kong, Tel: (852) 2887 4788, Fax: (852) 2508 1846