



Safety Switches Specifications

Bulletin Numbers 440G, 440H, 440K, 440N, 440T, and 442G

Topic	Page
Summary of Changes	2
Guard Locking Switches – Solid-state Switches (OSSD Safety Outputs)	
440G-MZ Guard Locking Switches	3
440G-LZ Guard Locking Switches	7
TLS-Z GD2 Guard Locking Switches	10
Guard Locking Switches – Electromechanical Switches (Voltage-free Contacts)	
TLS-GD2 Guard Locking Switches	13
440G-MT Guard Locking Switches	19
Atlas 5 Guard Locking Switches	24
440G-S Spartan Guard Locking Switches	28
Hinge Switches	
Sprite Miniature Hinge Interlock Switches	31
Ensign 3 Hinge Interlock Switches	35
Rotacam Heavy-duty Hinge Interlock Switches	39
Interlocking Switches with Guard Locking for Process Protection	
440G-EZ Electromagnetic Safety Switches	43
Interlocking Switches - Non-contact	
SensaGuard Non-contact Interlock Switches	46
Magnetically Coded Non-contact Interlock Switches	51
Ferrogard 1, 2, 20, and 21 Non-contact Interlock Switches	54
Ferrogard 3, 4, and 5 Non-contact Interlock Switches	57
Ferrogard 6, 9, 10, 13, and 14 Non-contact Interlock Switches	59
Ferrogard GD2 Non-contact Interlock Switches	63
Ferrogard GS1 and GS2 Non-contact Interlock Switches	66
Sipha Sensors	68

Topic	Page
Interlocking Switches - Electromechanical (Voltage-free Contacts)	
Elf Miniature Tongue Interlock Switches	73
Cadet 3 Tongue Interlock Switches	77
Trojan T15 Tongue Interlock Switches	81
Trojan 5 and 6 Universal Tongue Interlock Switches	85
MT-GD2 Tongue Interlock Switches	90
Trapped Key Interlock Switches	
Rotary Switches	100
Switch Operation	105
Solenoid Release Units	106
Electronic Timed-delay Units	110
Key Exchange Units	112
Bolt Interlocks	116
Operation	117
Access and Chains Trapped Key Interlock Switches	123
Prosafe Slamlock Mechanical Interlock Switches	129
Prosafe Slamlock Electrical Interlock Switches	132
Miniature Valve Trapped Key Interlock Switches	137
Switchgear Adapters	138
Accessories	140
Multi-functional Access Box	141
442G Multi-functional Access Box	141
442G Multi-functional Access Box with CIP Safety	146
Additional Resources	151

Safety switches are used to safeguard hazardous areas. Rockwell Automation provides a number of different safety switch configurations. This document describes guard locking, hinge, and interlock switches.

Guard locking switches are used to help protect an area when a danger is not immediately removed after a stop request, as in the case of high-inertia rotating machines, fast rotating machines, and machines where high pressure must be released from pneumatic valves.

Hinge switches, when triggered, close specific normally open (accessible) doors or guards.

Interlock switches monitor the position of a guard or gate. They can be used to shut off power, control personnel access, and help prevent a machine from starting when the guard is open.

Summary of Changes

This publication contains the following new or updated information. This list includes substantive updates only and is not intended to reflect all changes.

Topic	Page
Added UKCA Conformity	Throughout
Updated SensaGuard Non-contact Interlock Switches	46
Updated Table 40	32
Updated Table 45	36
Updated Table 68	55
Updated Table 69	55
Updated Table 72	56
Updated Table 100	74
Updated Table 101	74
Updated Table 107	78
Updated Table 111	82
Updated Table 115	86
Updated Table 117	87
Updated Table 133	102
Added Switch Operation	105
Updated Table 136	107
Added Figure 79	108
Added Figure 81	109
Updated Table 147	118
Updated Table 148	119
Updated Table 152	124
Updated Table 153	126
Updated Table 156	130
Updated Prosafe Slamlock Electrical Interlock Switches	132
Updated Table 159	133
Updated Table 160	134
Added Figure 113	136
Added Figure 114	136
Added Multi-functional Access Box	141
Added 442G Multi-functional Access Box with CIP Safety	146

Guard Locking Switches – Solid-state Switches (OSSD Safety Outputs)

440G-MZ Guard Locking Switches

The 440G-MZ guard locking switches have the following features:

- Certified to SIL 3, PLe, Cat 4 for door position monitoring and guard locking
- Embedded GuardLink® technology
- Type 4 interlocking device with guard locking per ISO 14119 with low or high coded RFID actuators
- High holding force of 2500 N
- Flexible actuator
- ±5 mm (0.2 in.) misalignment tolerance
- Energy-efficient bi-stable solenoid
- IP69K
- Power to Release and Power to Lock models
- DEVICE and LINK status is provided by two bright 270° status indicators



Specifications

Table 1 - Guard Locking Switch Specifications

Attribute	Value
Standards	IEC 60947-5-3, IEC 61508, ISO 13849-1, IEC 62061, ISO 14119, UL 508
Safety classification	Type 4 interlocking device with guard locking per ISO 14119 with low (standard) and high (unique) coding per ISO 14119 Suitable for use in applications up to and including PLe Cat 4 per ISO 13849-1, SIL CL 3 per IEC 62061, and SIL 3 per IEC 61508
Functional safety data	See publication 440G-UM004
Certifications	CE Marked for all applicable EU directives, UKCA Marked for all applicable regulations, cULus Listed, TÜV Certified rok.auto/certifications
Operating Characteristics	
Torque for M5 mounting of switch and actuator mounting bracket, max	2 N•m (17.7 lb•in)
Torque, auxiliary release access screw (escape release model)	0.56 N•m (5 lb•in)
Locking bolt alignment tolerance X, Y, Z, max	± 5 mm (0.2 in.)
Holding force F_{max} (ISO 14119)	3250 N
Holding force F_{zh} (ISO 14119)	2500 N
Output current, max (each output)	200 mA
Quiescent power consumption, locked or unlocked	1.5 W
Lock signal current	1 mA
Peak current and duration, at turn on or after lock/unlock operation	150 mA for approximately 800 ms following lock/unlock operation.
Steady state current, max	<ul style="list-style-type: none"> • OSSD mode: 40 mA • GuardLink mode: 50 mA
Operating voltage U_e	24V DC +10% / -15% Class 2 PELV
Operating cycle frequency, max	0.2 Hz
Dwell time between subsequent locking/unlocking	2.5 s
Response time (Off) (IEC 60947-5-3)	275 ms
Startup time (availability)	8 s
Utilization category (IEC 60947-5-2)	DC-13 24V 200 mA
Insulation voltage U_i (IEC 60947-5-1)	75V
Impulse withstand voltage U_{imp} (IEC 60947-5-1)	1 kV
Pollution degree (IEC 60947-5-1)	3
Auxiliary release	Built-in
Escape release	Built-in (select models)
Protection class (IEC 61140)	Class II
Mechanical life	500,000 cycles

Table 1 - Guard Locking Switch Specifications (Continued)

Attribute	Value	
Outputs (Guard door is closed and locked)		
Safety outputs	2 x PNP, 0.2 A max / ON (+24V DC)	
Environmental		
Operating temperature	0...55 °C (32...131 °F)	
Storage temperature	-25...+75 °C (-13...+167 °F)	
Operating humidity	5...95%, noncondensing	
Enclosure ingress rating	IP65, IP66, IP67, IP69, and IP69K	
Shock and vibration	<ul style="list-style-type: none"> IEC 60068-2-27, 30 g (1.1 oz), 11 ms IEC 60068-2-6, 10...55 Hz, 1 mm (0.4 in.) 	
Radio frequency/EMC	IEC 60947-5-3, FCC-1 (Parts 18 and 15), RED	
General		
Materials	Switch	Housing - ABS; front brace - SS304 (machined); SS316 (cast)
	Actuator	Housing and housing cover - SS304; spring - SS302; grommet - nitrile rubber; screws - stainless steel; tongue - SS410
	Brackets	High-strength low-alloy steel
	Accessories	Padlock - SS410; button - aluminum, powder painted; auxiliary release tool - SS304 with SS201 key ring; screw - steel
Weight	Switch	0.75 kg (1.7 lb)
	Actuator	0.27 kg (0.6 lb)
	Brackets	<ul style="list-style-type: none"> Actuator L: 0.27 kg (0.6 lb); Actuator Z: 0.54 kg (1.2 lb) Switch L: 1 kg (2.2 lb)
Protection Type	Short-circuit, current limitation, overload, reverse polarity, overvoltage (up to 60V max), thermal shutdown/restart	

Product Selection

Table 2 - Catalog Number Explanation

440G-MZS **20** **S** **N** **R** **J** **E**
 a b c d e f

a	
Outputs (Safety/Auxiliary)	
Code	Description
20	Two safety/no aux

b	
Actuator Code	
Code	Description
S	Standard code
U	Unique code

c	
Auxiliary Type	
Code	Description
N	No auxiliary

d	
Lock Type	
Code	Description
R	Power to Release
L	Power to Lock

e	
Connection Type	
Code	Description
J	M12 5-pin

f	
Special Features	
Code	Description
Blank	None
E	Escape release

Table 3 - Complete Switches, Including Switch Body and Actuator







Type	Actuator Coding	Escape Release	Cat No.
Power to Release	Standard (Low level to ISO 14119)	No	440G-MZS20SNRJ
	Unique (High level to ISO 14119)		440G-MZS20UNRJ
Power to Lock	Standard (Low level to ISO 14119)		440G-MZS20SNLJ
	Unique (High level to ISO 14119)		440G-MZS20UNLJ
Power to Release	Standard (Low level to ISO 14119)	Yes	440G-MZS20SNRJE
	Unique (High level to ISO 14119)		440G-MZS20UNRJE
Power to Lock	Standard (Low level to ISO 14119)		440G-MZS20SNLJE
	Unique (High level to ISO 14119)		440G-MZS20UNLJE

Accessories

Table 4 - Spare Actuators

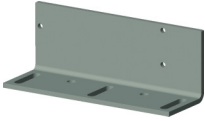
Description	Cat. No.
Standard code actuator (Low level to ISO 14119)	440G-MZAS
Unique code actuator (High level to ISO 14119)	440G-MZAU

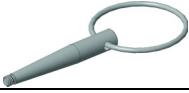
Table 5 - Accessories

Description		Cat. No.
	Actuator mounting bracket	L-shaped 440G-MZAM1
		Z-shaped 440G-MZAM2
	Switch mounting bracket	440G-MZAM3
	Padlock accessory	440G-MZAL
	Auxiliary release tool	440G-MZAT
	Replacement screw	440G-MZRSC
	Replacement button	440G-MZRBU

Approximate Dimensions

Dimensions are not intended to be used for installation purposes.

Figure 1 - Switch Body [mm (in.)]

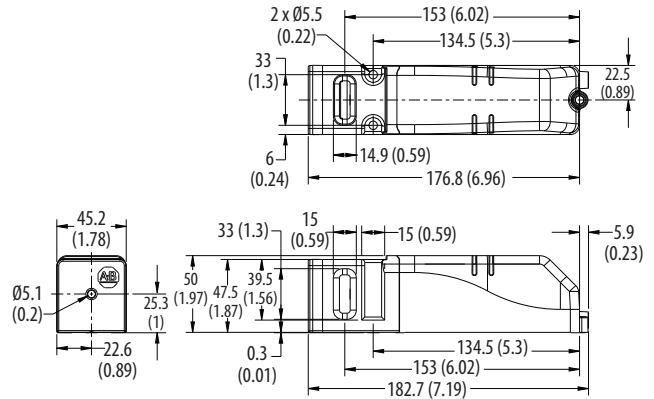
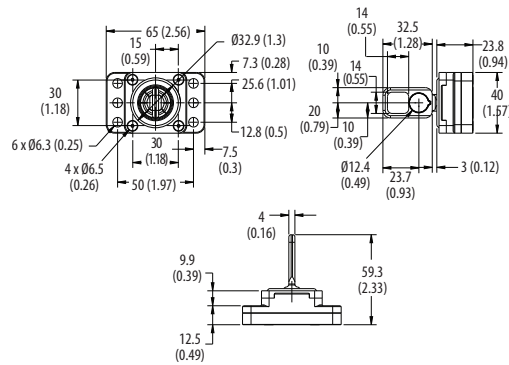

Figure 2 - Actuator [mm (in.)]



Pin Assignment

Table 6 - 5-pin Micro (M12) ⁽¹⁾



Pin	Color	Function	
		OSSD Mode	GuardLink Mode
1	Brown	+24V	+24V
2	White	Safety A	Safety In
3	Blue	0V	0V
4	Black	Safety B	Safety out
5	Gray	Lock command	Command, Lock, and Unlock (CLU)

(1) The recommended cordset is catalog number 889D-F5AC-2 (2 m [6.6 ft]). Replace the 2 with 5 [5 m (16.4 ft)] or 10 [10 m (32.8 ft)] for standard cable lengths. The recommended patchcord for use with ArmorBlock® Guard I/O™ is the 2 m (6.6 ft) catalog number 889D-F5ACDM-2. Replace the 2 with OM3 [OM3 (0.98 ft)], 1 [1 m (3.3 ft)], 5 [5 m (16.4 ft)], or 10 [10 m (32.8 ft)] for standard cable lengths.

Connection in a GuardLink System

The 440G-MZ safety switch can be connected to a GuardLink system via a passive tap (catalog number 440S-PF5D shown in Figure 3) or a passive power tap (catalog number 440S-PF5D4).

Figure 3 - Connect 440G-MZ Switch to a GuardLink System with a Passive Tap

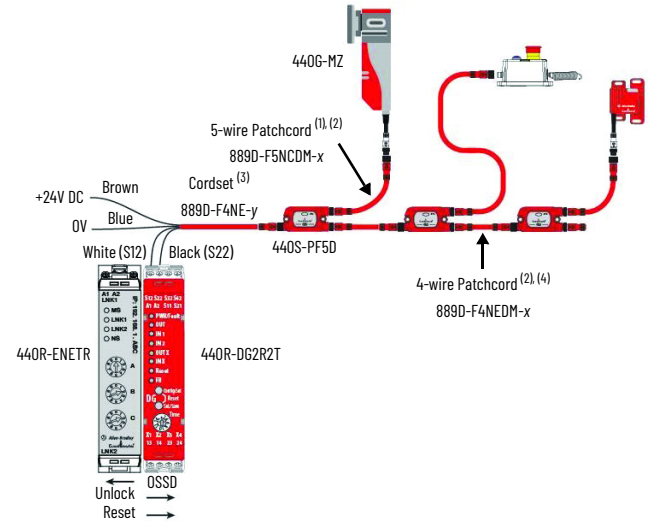

- (1) 10 m (32.8 ft) length, max
- (2) Replace x with OM3 (300 mm [0.98 ft]), OM6 (600 mm [1.97 ft]), 1 (1 m [3.3 ft]), 2 (2 m [6.6 ft]), 5 (5 m [16.4 ft]), or 10 (10 m [32.8 ft]) for standard cable lengths.
- (3) Replace y in order number with 2 (2 m [6.6 ft]), 5 (5 m [16.4 ft]), 10 (10 m [32.8 ft]), 15 (15 m [49.2 ft]), 20 (20 m [65.6 ft]), or 30 (30 m [98.4 ft]) for standard cable lengths.
- (4) 30 m (98.4 ft) length, max

440G-LZ Guard Locking Switches

The 440G-LZ guard locking switches have the following features:

- Certified to PLe to ISO 13849-1 (both for door position and lock monitoring to ISO 14119)
- Solid-state design and monitored outputs
- Type 4 interlocking device with guard locking per ISO 14119 with low or high coded RFID actuators
- High holding force of 1300 N
- Energy-efficient green device that only uses 2.5 W
- IP69k and hygienic design
- Power to Release and Power to Lock versions
- Auxiliary output versions: lock status or guard proximity
- Compact design that is optimized for ease of mounting
- Diagnostic information provided by two bright 270° status indicators
- Solid-state OSSD outputs series connectable to ISO 14119



Specifications

Table 7 - Guard Locking Switch Specifications

Attribute	Value
Safety ratings	
Standards	ISO 14119, IEC 60947-5-3, ISO 13849-1, IEC 62061
Safety classification	Type 4 interlocking device with guard locking per ISO 14119 with low (standard) and high (unique) coding per ISO 14119 PLe Cat 4 per ISO 13849-1 and SIL 3 per IEC 62061
Functional safety	See publication SAFETY-SR001
Certifications	cULus Listed, TÜV Certified, UKCA Marked for all applicable regulations, and CE Marked for all applicable directives rok.auto/certifications
Operating characteristics	
Torque for M5 mounting of switch and actuator mounting bracket, max	2 N•m,
Locking bolt insertion for assured locking and holding force	Min of 5 mm (0.19 in.), max of 10 mm (0.39 in.)
Locking bolt alignment tolerance X, Y, Z	Max of ±2.5 mm (0.09 in.)
Holding force Fmax (ISO 14119)	1690 N
Holding force Fzh (ISO 14119)	1300 N
Output current, max (each output)	200 mA
Quiescent power consumption, locked or unlocked	2.5 W
Peak current and duration, at turn on or after lock/unlock operation	400 mA / 100 ms
Operating voltage Ue	24V DC +10% / -15% Class 2 SELV
Frequency of operating cycles, max	0.2 Hz
Dwell time between subsequent locking/unlocking	2.5 s
Response time (off)	100 ms first switch, 50 ms additional for each switch
Risk time (according to IEC 60947-5-3)	100 ms
Startup time (availability)	8 s

Table 7 - Guard Locking Switch Specifications (Continued)

Attribute	Value
Length of a chain of switches, max	10 km (6.2 mi) Dependent on cable/connection/required response time
Utilization category (IEC 60947-5-2)	DC-13 24V 200 mA
Insulation voltage Ui (IEC 60947-1)	75V
Impulse withstand voltage Uimp (IEC 60947-1)	1 kV
Pollution degree (IEC 60947-1)	3
Manual (auxiliary) release	Built in
Protection class (IEC 61140)	Class II
Mechanical life	500,000 cycles
Outputs (guard door is closed and locked)	
Safety outputs	2 x PNP, 0.2 A max / ON (+24V DC)
Auxiliary outputs	1 x PNP, 0.2 A max / OFF (0V DC)
Environmental	
Operating temperature	0...55 °C (14...131 °F)
Storage temperature	-25...+75 °C (-13...+167 °F)
Operating humidity	5...95% relative
Enclosure ingress rating	NEMA 3, 4X, 12, 13, IP66, IP67, IP69k
Shock and vibration	IEC 60068-2-27 30 g, 11 ms/IEC 60068-2-6 10...55 Hz, 1 mm (0.04 in.)
Hygienic	ISO 14159:2004 and EN 1672-2005 (for that part of the machine that is defined as food splash area)
Washdown	Sodium Hydroxide based washdown fluids
Radio frequency / EMC	IEC 60947-5-3, FCC-1 (Parts 18 and 15), RandTTE
General	
Materials	ABS, locking bolt and mounting bracket 304 stainless steel
Weight	Switch 400 g (0.9 lb), actuator 150 g (0.3 lb), actuator mounting bracket 60 g (0.1 lb)
Protection Type	Short-circuit, current limitation, overload, reverse polarity, overvoltage (up to 60V max), thermal shutdown/restart

Product Selection

Table 8 - Guard Locking Switch Product Selection

Locking Type	Actuator Type	Cat. No.					
		Connector Type					
		Aux. Output = Lock Aux.			Aux. Output = Door Aux.		
		3 m (9.8 ft) Lead	10 m (32.8 ft) Lead	6 in. (152.4 mm) Pigtail with M12 8-pin QD	3 m (9.8 ft) Lead	10 m (32.8 ft) Lead	6 in. (152.4 mm) Pigtail with M12 8-pin QD
Power to Release	Standard (low level to ISO 14119)	440G-LZS21SPRA	440G-LZS21SPRB	440G-LZS21SPRH	440G-LZS21STRA	440G-LZS21STRB	440G-LZS21STRH
	Unique (high level to ISO 14119)	440G-LZS21UPRA	440G-LZS21UPRB	440G-LZS21UPRH	440G-LZS21UTRA	440G-LZS21UTRB	440G-LZS21UTRH
Power to Lock	Standard (low level to ISO 14119)	440G-LZS21SPLA	440G-LZS21SPLB	440G-LZS21SPLH	440G-LZS21STLA	440G-LZS21STLB	440G-LZS21STLH
	Unique (high level to ISO 14119)	440G-LZS21UPLA	440G-LZS21UPLB	440G-LZS21UPLH	440G-LZS21UTLA	440G-LZS21UTLB	440G-LZS21UTLH

Accessories

Table 9 - Spare Actuators

Locking Type	Actuator Type	Cat. No.
Power to Release	Standard (low-level ISO 14119)	440G-LZASPR
	Unique (high-level ISO 14119)	440G-LZAUPR
Power to Lock	Standard (low-level ISO 14119)	440G-LZASPL
	Unique (high-level ISO 14119)	440G-LZAUPL

Table 10 - Mounting Brackets

Description	Cat. No.
Actuator mounting bracket	440G-LZAM1
Switch body mounting bracket	440G-LZAM2

Approximate Dimensions

Dimensions are not intended to be used for installation purposes.

Figure 4 - Switch Body [mm (in.)]

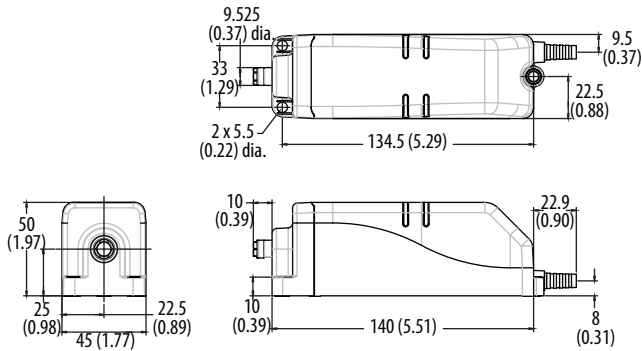

Figure 5 - Actuator and Actuator Mounting Bracket (440G-LZAM1) [mm (in.)]

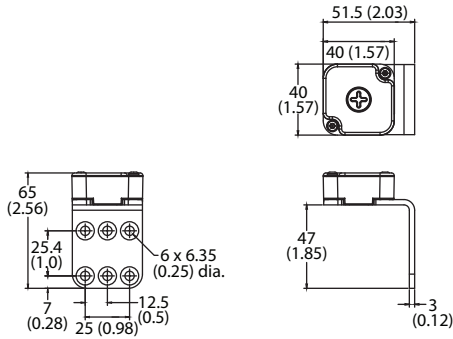
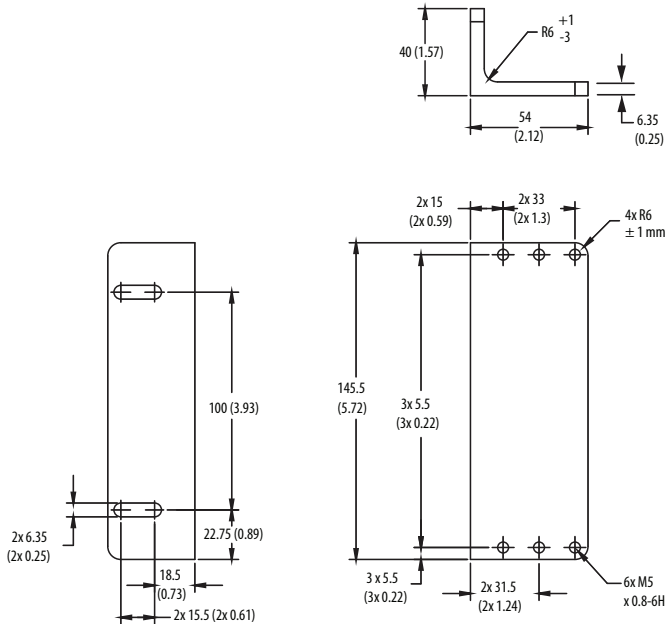

Figure 6 - Switch Mounting Bracket (440G-LZAM2) [mm (in.)]



Typical Wiring Diagrams

Table 11 - Guard Locking Switch Wiring

		8-pin Micro (M12)	
8-pin Cordset 889D-F8AB-x ⁽¹⁾ or Cable Version	Color	Function	Pin
	White	Aux	1
	Brown	24V DC +	2
	Green	Lock	3
	Yellow	Safety B+	4
	Gray	Safety A	5
	Pink	Safety B	6
	Blue	Gnd/0V	7
Red	Safety A+	8	

(1) Replace x with 2 (2 m [6.6 ft]), 5 (5 m [16.4 ft]), or 10 (10 m [32.8 ft]) for standard cable lengths.

TLS-Z GD2 Guard Locking Switches

The TLS-ZR GD2 and the TLS-ZL GD2 guard locking switches have the following features:

- Meets PLe to ISO 13849-1
- Solid-state OSSD outputs series connectable to ISO 14119
- RFID uniquely coded door target
- Easy QD connection
- Same mechanical arrangement as standard TLS-GD2
- High locking force ≤ 2000 N (450 lbf)

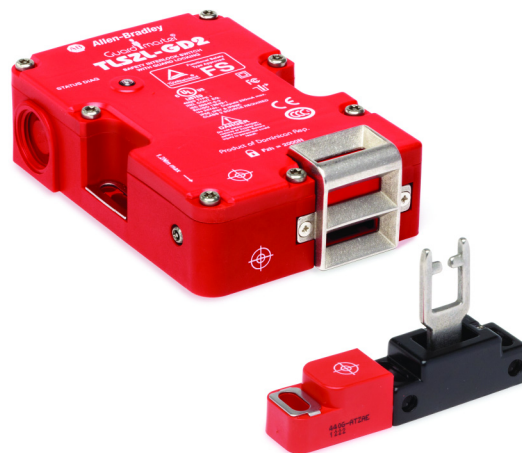

Specifications

Figure 7 - Guard Locking Switch Specifications

Attribute	Value
Safety ratings	
Standards	ISO 14119, IEC 60947-5-3, ISO 13849-1
Safety classification	Type 4 interlocking device with guard locking per ISO 14119 with high (unique) coding per ISO 14119 PLe Cat 4 per ISO 13849-1
Functional safety	See publication SAFETY-SR001
Certifications	cULus Listed, TÜV Certified, UKCA Marked for all applicable regulations, and CE Marked for all applicable directives rok.auto/certifications
Outputs (guard door is closed and locked)	
Safety outputs	2 x PNP, 0.2 A max, status: ON (+24V DC)
Auxiliary outputs	1 x PNP, 0.2 A max, status: OFF (0V DC)
Operating characteristics	
TLSZR-GD2	Power to Release
TLSZL-GD2	Power to Lock
Assured locking distance	<ul style="list-style-type: none"> • Door target distance, max: 13 mm (0.51 in.) • Clearance between actuator base and switch in door-closed position, max: 5 mm (0.2 in.)
Torque for M5 mounting	1.4 N•m (12.39 lbf•in)
Torque for cover mounting	1.2 N•m (10.62 lbf•in)
Holding force F_{max} (ISO 14119)	<ul style="list-style-type: none"> • Plastic pins: 1950 N (488 lbf) • Steel bolts: 2600 N (585 lbf)
Holding force F_{zh} (ISO 14119)	<ul style="list-style-type: none"> • Plastic pins: 1500 N (337 lbf) • Steel bolts: 2000 N (450 lbf)
Output current, max (all outputs)	200 mA
Current consumption	50 mA – Solenoid not energized (no load supply current); 120 mA (260 mA inrush) – Solenoid energized (no load supply current); <0.5 mA DC – Off state
Solenoid duty cycle	100%
Number of switches (connected in series), max	Unlimited
Operating voltage U_e	24V DC +10%/-15% Class 2
Operating frequency	1 Hz
Actuation speed, max	160 mm (6.29 in.) per second
Actuation speed, min	100 mm (3.94 in.) per minute
Response time	75 ms first switch, 25 ms each additional switch (Off)
Utilization category	DC-13 24V 200 mA (IEC 60947-5-2)
Rated impulse withstand voltage	250V

Figure 7 - Guard Locking Switch Specifications (Continued)

Attribute	Value
Pollution degree	3
Protection Type	2
Mechanical life	1,000,000 operations
Actuation speed, max	160 mm (6.29 in.) per second
Operating radius (only for use with flexible actuator)	80 mm (3.15 in.)
Environmental	
Enclosure type rating	NEMA 3, 4X, 12, 13; IP66, IP69K
Operating temperature	-10...+60 °C (14...140 °F)
Relative humidity	5...95%
Shock and vibration	IEC 60068-2-27 30 g, 11 ms/IEC 60068-2-6 10...55 Hz, 1 mm (0.04 in.)
Frequency	IEC 61000-4-3, IEC 61000-4-6
Physical characteristics	
Material	<ul style="list-style-type: none"> • Housing: UL Approved glass-filled PBT • Actuator: Stainless steel
Target type	UL Approved glass-filled PBT
Weight	400 g (0.88 lb)
Color	Red

Product Selection



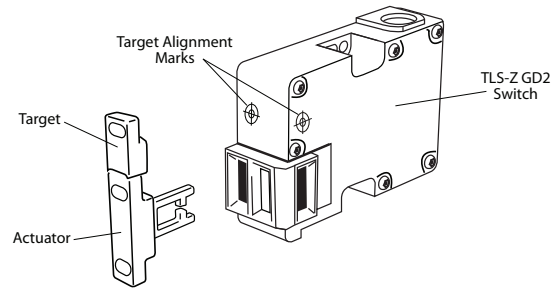

Table 12 - Guard Locking Switch Product Selection







Locking Type	Actuator Type	Connector Type	Cat. No.	
			Aux. Output = Lock Aux.	Aux. Output = Door Aux.
Power to Release	Unique (high level to ISO 14119)	8-in. Pigtail with M12 8-pin QD	440G-TZS21UPRH	440G-TZS21UTRH
Power to Lock			440G-TZS21UPLH	440G-TZS21UTLH

Accessories

Table 13 - Guard Locking Switch Accessories

Description	Cat. No.
 Spare RFID door target	440G-ATZA
 Fully flexible actuator	440G-A27143
 Cover for TLS-1 with external override key for series E and later	440G-A27371
 Cover for TLS-1 with override key that is attached for series E and later	440G-A27373

Description	Cat No.
 Emergency override key (See the following Attention)	440G-A36026
 Flexible release—1 m (3.3 ft) cable	440G-A27356 ⁽¹⁾
 Flexible release—3 m (9.8 ft) cable	440G-A27357 ⁽¹⁾
 Dust cover	440K-A17183

(1) Flexible release cannot be used with Power to Lock switches.



ATTENTION: Do not attach the emergency override key to the TLS-Z-GD2 switch.

Approximate Dimensions

Dimensions are not intended to be used for installation purposes.

Figure 8 - Guard Locking Switch [mm (in.)]

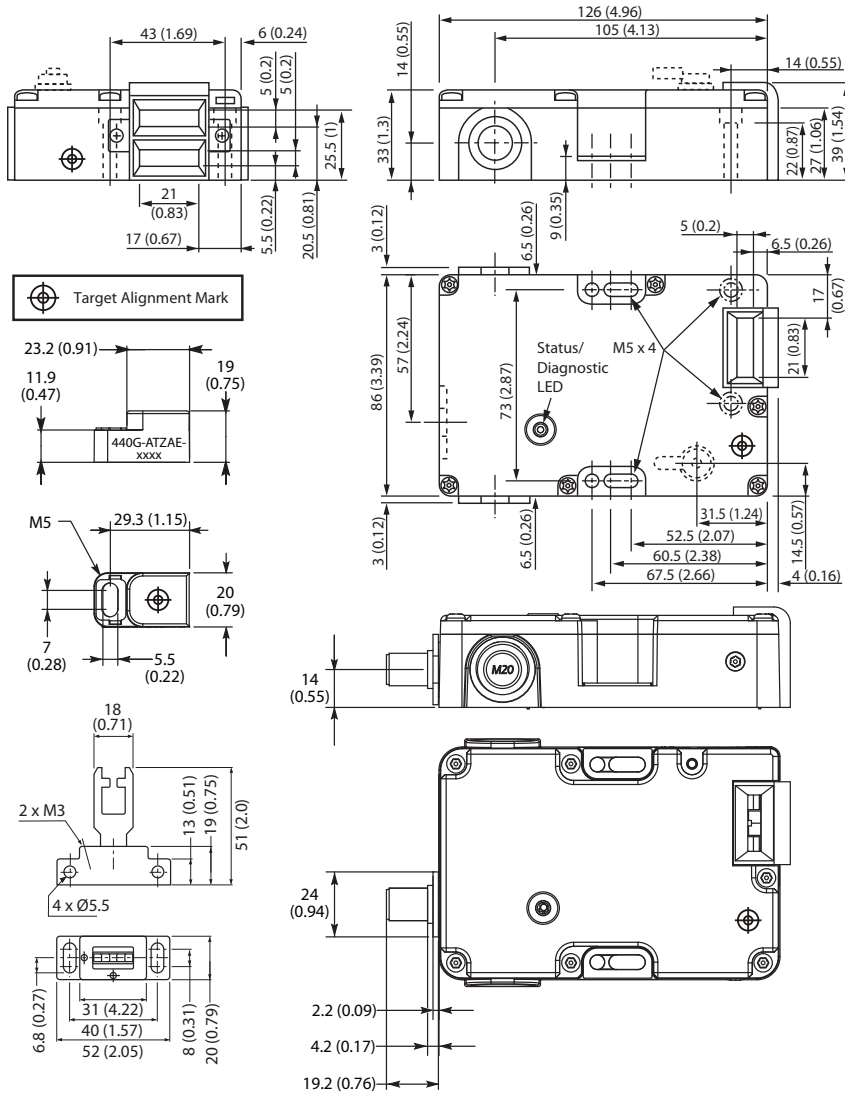

Typical Wiring Diagrams

Table 14 - Guard Locking Switch Wiring

8-pin Micro (M12)			
8-pin Cordset 889D-F8AB-x ⁽¹⁾ or Cable Version	Color	Function	Pin
	White	Aux	1
	Brown	24V DC +	2
	Green	Lock	3
	Yellow	Safety B+	4
	Gray	Safety A	5
	Pink	Safety B	6
	Blue	Gnd/OV	7
Red	Safety A+	8	

(1) Replace x with 2 (2 m [6.6 ft]), 5 (5 m [16.4 ft]), or 10 (10 m [32.8 ft]) for standard cable lengths.

Guard Locking Switches – Electromechanical Switches (Voltage-free Contacts)

TLS-GD2 Guard Locking Switches

The TLS-GD2 guard locking switches have the following features:

- Power to Release or Power to Lock
- High locking force ≤ 2000 N (450 lbf)
- Five contacts: 2 N.C. and 1 N.O. for door position monitoring 1 N.C. and 1 N.O. or 2 N.C. for lock monitoring
- Rotatable head: Four possible key entry slots
- Conforms to ISO 14119 and IEC 60947-5-1
- Escape release version available
- IP69K, suitable for high pressure, high temperature washdown

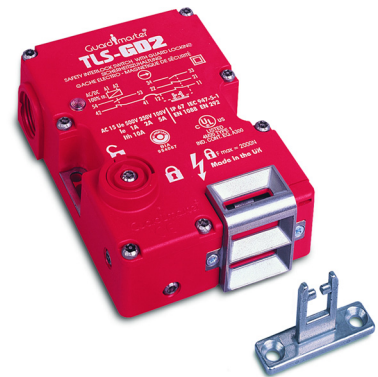

Specifications

Table 15 - Guard Locking Switch Specifications

Attribute	Value			
Safety Ratings				
Standards	ISO 14119, IEC 60947-5-1			
Safety classification	Type 2 interlocking device with guard locking and low coding (tongue) per ISO 14119			
Functional safety	See publication SAFETY-SR001			
Certifications	cULus Listed, TÜV Certified, UKCA Marked for all applicable regulations, and CE Marked for all applicable directives rok.auto/certifications			
Outputs				
Safety contacts ⁽¹⁾	<ul style="list-style-type: none"> • TLS-1 and -2: 3 N.C. direct opening action • TLS-3: 4 N.C. direct opening action 			
Auxiliary contacts	<ul style="list-style-type: none"> • TLS-1 and -2: 2 N.O. (1 solenoid monitoring) • TLS-3: 1 N.O. 			
Thermal current/ I_{th}	10 A			
Rated insulation voltage (U_i)	500V			
Switching current at voltage, min	3 mA at 18V DC			
Utilization Category				
A600/AC-15 (Ue)	600V	500V	240V	120V
A600/AC-15 (Ie)	1.2 A	1.4 A	3 A	6 A
DC-13 (Ue)	24V			
DC-13 (Ie)	2 A			
Solenoid Characteristics				
Holding force F_{max} (ISO 14119)	<ul style="list-style-type: none"> • Plastic pins: 1950 N (488 lbf) • Steel bolts: 2600 N (585 lbf) 			
Holding force F_{zh} (ISO 14119)	<ul style="list-style-type: none"> • Plastic pins: 1500 N (337 lbf) • Steel bolts: 2000 N (450 lbf) 			
Power supply	24V AC/DC or 110V AC or 230V AC (solenoid)			
Solenoid power	7 W typical 100% ED			
Escape release button	Force max: 50 N (11.25 lbf)			

Table 15 - Guard Locking Switch Specifications (Continued)

Attribute	Value
Operating Characteristics	
Break contact force, min	20 N (4.5 lbf)
Actuation speed, max	160 mm (6.29 in.)/s
Actuation frequency, max	1 cycle/s
Operating radius, min	160 mm (6.3 in.) [80 mm (3.15 in.) with flexible actuator]
Mechanical life	1,000,000 operations
Environmental	
Enclosure type rating	IP66, IP67, IP69K
Operating temperature	-20...+60 °C (-4...+140 °F)
Physical Characteristics	
Material	<ul style="list-style-type: none"> • Housing: UL Approved glass-filled PBT • Actuator: Stainless steel
Weight	400 g (0.88 lb)
Color	Red

(1) The safety contacts are described as normally closed (N.C.) that is, with the guard closed, actuator in place (where relevant), and the machine able to be started.

Product Selection

Table 16 - Guard Locking Switch Product Selection

Type	Contacts		Solenoid		Actuator Type	Cat. No.							
	Safety	Auxiliary	Contacts	Voltage		Conduit		Connector ⁽¹⁾					
						M20	1/2 inch NPT Adapter	12-pin M23	8-pin Micro (M12) ⁽²⁾				
TLS-1 GD2 Power to Release	2 N.C.	1 N.O.	1 N.C. and 1 N.O.	24V AC/DC	—	440G-T27121	—	440G-T27233	440G-T2NBBPH-1R				
					GD2 Standard	440G-T27251	440G-T27169	440G-T27234	—				
					Fully flexible	440G-T27252	440G-T27171	440G-T27235	—				
				110V AC/DC	—	440G-T27124	—	—	—				
					GD2 Standard	440G-T27253	440G-T27172	—	—				
					Fully flexible	440G-T27254	440G-T27174	—	—				
				230V AC/DC	—	440G-T27123	—	—	—				
				TLS-2 GD2 Power to Lock	2 N.C.	1 N.O.	1 N.C. and 1 N.O.	24V AC/DC	—	440G-T27127	—	440G-T27239	440G-T2NBBPH-1L
									GD2 Standard	440G-T27255	440G-T27175	440G-T27240	—
Fully flexible	440G-T27256	440G-T27177	440G-T27241						—				
110V AC/DC	—	440G-T27132	—					—	—				
	GD2 Standard	440G-T27257	440G-T27178					—	—				
	Fully flexible	440G-T27258	440G-T27180					—	—				
230V AC/DC	—	440G-T27129	—					—	—				
TLS-3 GD2 Power to Release	2 N.C.	1 N.O.	2 N.C.					24V AC/DC	—	440G-T27134	—	440G-T27245	440G-T2NBBPH-2R
									GD2 Standard	440G-T27259	440G-T27181	440G-T27246	—
				Fully flexible	440G-T27260	440G-T27183	440G-T27247		—				
				110V AC/DC	—	440G-T27138	—	—	—				
					GD2 Standard	440G-T27261	440G-T27184	—	—				
					Fully Flexible	440G-T27262	440G-T27186	—	—				
				230V AC/DC	—	440G-T27136	—	—	—				
				TLS-1 GD2 Power to Release with Escape Release	2 N.C.	1 N.O.	1 N.C. and 1 N.O.	24V AC/DC	—	440G-T21BNPM-1B	440G-T21BNPT-1B	440G-T21BNPL-1B	440G-T2NBNPH-1B
									GD2 Standard	440G-T21BGPM-1B	440G-T21BGPT-1B	440G-T21BGPL-1B	—
Fully flexible	440G-T21BGPM-1B	440G-T21BGPT-1B	440G-T21BGPL-1B						—				
110V AC/DC	—	440G-T21BNPM-4B	440G-T21BNPT-4B					—	—				
	GD2 Standard	440G-T21BGPM-4B	440G-T21BGPT-4B					—	—				
	Fully flexible	440G-T21BGPM-4B	440G-T21BGPT-4B					—	—				
TLS-3 GD2 Power to Release with Escape Release	2 N.C.	1 N.O.	2 N.C.	24V AC/DC	—	440G-T21BNPM-2B	440G-T21BNPT-2B	440G-T21BNPL-2B	440G-T2NBNPH-2B				
					GD2 Standard	440G-T21BGPM-2B	440G-T21BGPT-2B	440G-T21BGPL-2B	—				
					Fully flexible	440G-T21BGPM-2B	440G-T21BGPT-2B	440G-T21BGPL-2B	—				
				110V AC/DC	—	440G-T21BNPM-5B	440G-T21BNPT-5B	—	—				
					GD2 Standard	440G-T21BGPM-5B	440G-T21BGPT-5B	—	—				
					Fully flexible	440G-T21BGPM-5B	440G-T21BGPT-5B	—	—				

(1) For connector ratings, see [Table 23 on page 20](#).(2) With an 8-pin micro connector, not all contacts are connected. See [Typical Wiring Diagrams on page 17](#) for wiring details.
Table 17 - Connection Systems

Description	8-pin Micro (M12)	12-wire, 12-pin M23	9-wire, 12-pin M23 ⁽¹⁾
Cordset	889D-F8AB-x ⁽²⁾	889M-F12AH-x ⁽²⁾	889M-F12X9AE-x ⁽²⁾
Patchcord	889D-F8ABDM-y ⁽³⁾	889M-F12AHMU-z ⁽⁴⁾	—

(1) The 9-wire cordset can be used only with the TLS3 versions.

(2) Replace x with 2 (2 m [6.6 ft]), 5 (5 m [16.4 ft]), or 10 (10 m [32.8 ft]) for standard cable lengths.

(3) Replace y with 1 (1 m [3.3 ft]), 2 (2 m [6.6 ft]), 3 (3 m [9.8 ft]), 5 (5 m [16.4 ft]), or 10 (10 m [32.8 ft]) for standard cable lengths.









(4) Replace z with 0M3 (0.3 m [1 ft]), 0M6 (0.6 m [2 ft]), 1 (1 m [3.3 ft]), 2 (2 m [6.6 ft]), or 3 (3 m [9.8 ft]) for standard lengths.

Accessories

Table 18 - Guard Locking Switch Accessories

Description	Cat. No.
 GD2 standard actuator	440G-A27011
 GD2 flat actuator	440K-A11112
 Extended flat actuator	440K-A17116
 Fully flexible actuator	440G-A27143
 Sliding bolt actuator not to be used with the TLS1 Escape Release	440G-A27163
 Emergency override key (See the following Attention)	440G-A36026
 Flexible release—1 m (3.3 ft) cable	440G-A27356 ⁽¹⁾
 Flexible release—3 m (9.8 ft) cable	440G-A27357 ⁽¹⁾
 Dust cover	440K-A17183
 Sliding bolt	440K-AMDS

(1) Flexible release cannot be used with Power to Lock switches.

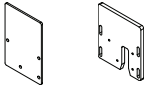
Description	Cat. No.
 Cover for TLS-1 with external override key for series D and earlier	440G-A27140
 Cover for TLS-3 with external override key for series D and earlier	440G-A27142
 Cover for TLS-1 with override key that is attached for series D and earlier	440G-A27207
 Cover for TLS-3 with override key that is attached for series D and earlier	440G-A27208
 Cover for TLS-1 with external override key for series E and later	440G-A27371
 Cover for TLS-3 with external override key for series E and later	440G-A27372
 Cover for TLS-1 with override key that is attached for series E and later	440G-A27373
 Cover for TLS-3 with override key that is attached for series E and later	440G-A27374
 Mounting plate	440K-AMDSSMPB



ATTENTION: Do not attach the emergency override key to the TLS-GD2 switch.

Approximate Dimensions

Dimensions are not intended to be used for installation purposes.

Figure 9 - Guard Locking Switch Dimensions [mm (in.)]

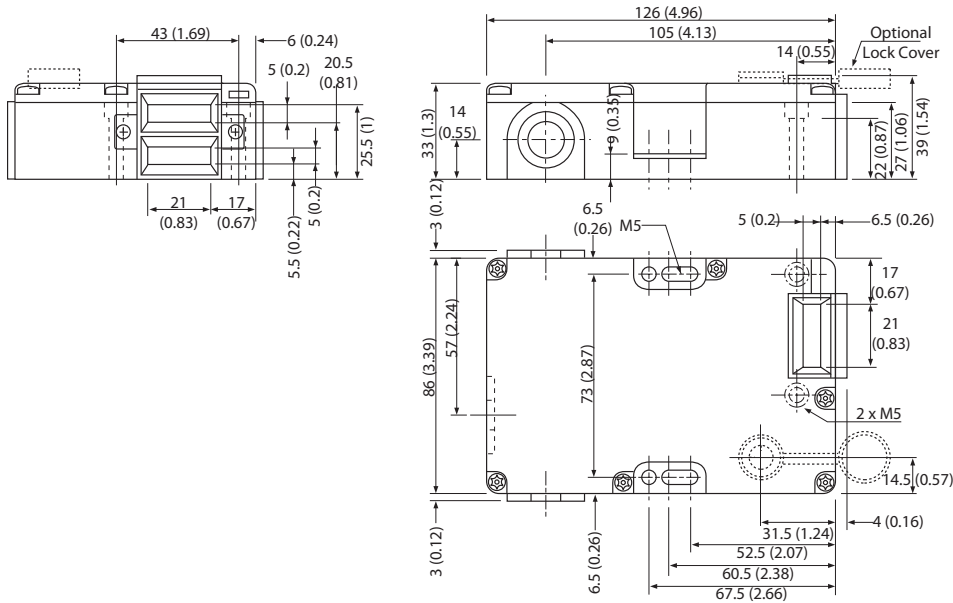
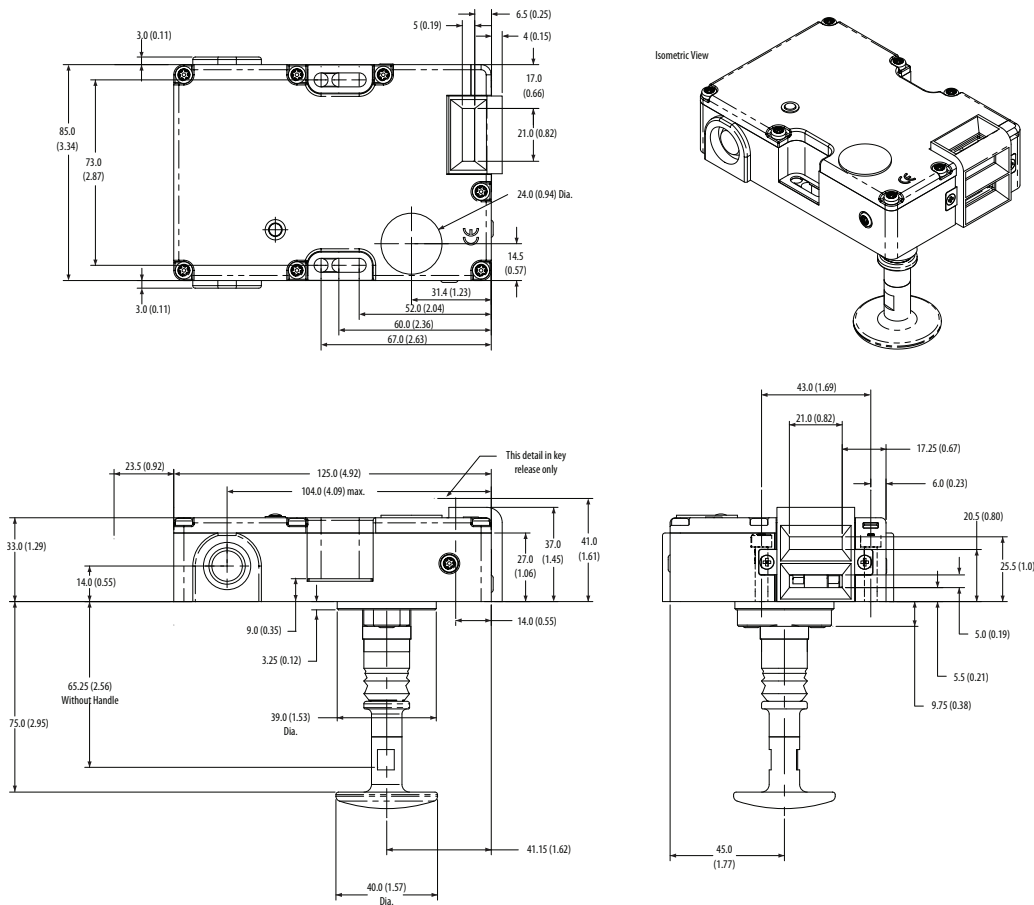

Figure 10 - TLS-GD2 Escape Release [mm (in.)]



Typical Wiring Diagrams

Table 19 - Guard Locking Switch Wiring

Description		TLS1	TLS2	TLS3	
Contact Configuration		<p>Jumper between 12 and 41 and 22 and 51</p>		<p>Jumper between 12 and 41 and 22 and 51</p>	
Contact Action □ Open ■ Closed		<p>BBM</p>	<p>BBM</p>	<p>BBM</p>	
8-pin Micro (M12)		<p>No jumper on 12-41</p>		<p>Jumper on 12-41 and 22-51</p>	
12-pin M23		1 and 3	Solenoid Power	1 and 3	Solenoid Power
		4 and 12	Safety A ⁽¹⁾	4 and 12	Safety A ⁽¹⁾
		7 and 8	Safety B	7 and 5	Safety B ⁽¹⁾
		9 and 10	Aux A	9 and 10	Aux A
		6 and 11	Solenoid A ⁽¹⁾	6 and 11	Solenoid A ⁽¹⁾
		2 and 5	Solenoid B	2 and 8	Solenoid B ⁽¹⁾
8-pin Cordset 889D-F8AB-x ⁽²⁾	Brown Blue	Solenoid power		Solenoid power	
	Gray Red	Safety A		Safety A and Solenoid A	
	Yellow Pink	Safety B		Safety B and Solenoid B	
	White Green	Solenoid A		Solenoid A	
12-pin, 9-wire Cordset 889M-F12X9AE-x ⁽²⁾ (Pink/Yellow: Not connected)		Cannot be used		Brown Blue	Solenoid Power
				White Green	Safety A and Solenoid A
				Yellow Gray	Safety B and Solenoid B
				Pink Red	Aux A

Table 19 - Guard Locking Switch Wiring (Continued)

Description	TLS1	TLS2	TLS3	
12-pin, 12-wire Cordset 889M-F12AH-x ⁽²⁾	Brown Gray	Solenoid Power	Brown Gray	Solenoid Power
	Pink Green	Safety A ⁽¹⁾	Pink Green	Safety A ⁽¹⁾
	White Red/Blue	Safety B	White Red	Safety B ⁽¹⁾
	Black Violet	Aux A	Black Violet	Aux A
	Gray/Pink Yellow	Solenoid A ⁽¹⁾	Grey/Pink Yellow	Solenoid A ⁽¹⁾
	Blue Red	Solenoid B	Blue Red/Blue	Solenoid B ⁽¹⁾

(1) See warning statements on [page 18](#).

(2) Replace x with 2 (2 m [6.6 ft]), 5 (5 m [16.4 ft]) or 10 (10 m [32.8 ft]) for standard cable lengths.



WARNING: To monitor independently one or more safety contacts and the solenoid feedback (TLS 1, 2, and 3):

- The 12-wire cordset 889M-F12AH-footnote must be used and
- For the TLS1 and TLS2, the jumper from 12 to 41 must be removed.
- For the TLS3, the jumpers between 12 and 41 and 22 and 51 must be removed.



WARNING: Monitoring of one or more safety contacts and the solenoid feedback (in series) is available, when jumpers are in place and:

- For the TLS1 and TLS2, by using pins 4 and 6 on the 12-pin, M23 receptacle or Pink and Yellow wires on the 12-wire cordset (889M-F12AH-x⁽¹⁾).
- For the TLS3, by using pins 4 and 6 and pins 7 and 8 on the 12-pin, M23 receptacle or Pink and Yellow and White and Red/Blue wires on the 12-wire cordset (889M-F12AH-x⁽¹⁾).

(1) Replace x with 2 (2 m [6.6 ft]), 5 (5 m [16.4 ft]), or 10 (10 m [32.8 ft]) for standard cable lengths.

440G-MT Guard Locking Switches

The 440G-MT solenoid switch locks a machine guard closed and can only be opened when a signal is applied to the internal solenoid, which releases the lock mechanism.

The 440G-MT guard locking solenoid switches have the following features:

- Type 2 Interlocking Device with Guard Locking and low coding per ISO 14119
- High Fzh (holding force): 1500 N (337 lb)
- Mechanical lock (Power to Release)
- Heavy-duty, die-cast alloy housing for use in harsh environments
- Diagnostic version available with built-in status indicator to indicate door status independent of lock status

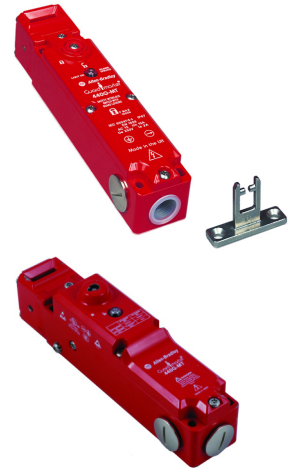

Specifications

Table 20 - Guard Locking Switch Specifications

Attribute	Value			
Safety Ratings				
Standards	ISO 14119, IEC 60947-5-1			
Safety classification	Type 2 Interlocking Device with Guard Locking and low coding per ISO 14119			
Functional safety	See publication SAFETY-SR001			
Certifications	cULus Listed, TÜV Certified, UKCA Marked for all applicable regulations, and CE Marked for all applicable directives rok.auto/certifications			
Outputs				
Safety contacts ⁽¹⁾	3 N.C. or 2 N.C. direct opening action			
Auxiliary contacts	1 N.O. or 2 N.O.			
Thermal current/ I_{th}	10 A			
Rated insulation voltage (Ui)	500V			
Switching current at voltage, min	3 mA at 18V DC			
Utilization Category				
A600/AC-15 (Ue)	600V	500V	240V	120V
A600/AC-15 (Ie)	1.2 A	1.4 A	3 A	6 A
DC-13 (Ue)	24V			
DC-13 (Ie)	2 A			
Solenoid Characteristics				
Locking type	Power to Release			
Holding force, max	1600 N (360 lbf)			
Power supply	24V AC/DC or 110V AC or 230V AC			
Solenoid power	13 W typical 100% ED			
Operating Characteristics				
Break contact force, min	6 N (1.35 lbf)			
Actuation speed, max	160 mm (6.29 in.)/s			
Actuation frequency, max	2 cycles/s			
Operating radius, min	60 mm (2.36 in.)			
Mechanical life	1,000,000 operations			
Environmental				
Enclosure type rating	IP67			
Operating temperature	-25...+60 °C (13...140 °F)			
Physical Characteristics				
Material	<ul style="list-style-type: none"> • Housing: Painted zinc alloy • Actuator: Stainless steel 			
Weight	1400 g (3.08 lb)			
Color	Red			

(1) The safety contacts are described as normally closed (N.C.) that is, with the guard closed, actuator in place (where relevant), and the machine able to be started.

Product Selection

Table 21 - Guard Locking Switch Product Selection

Solenoid Voltage	Contact			Actuator Type	Cat. No.			
	Safety	Auxiliary	Action		M20 Conduit		Connector ⁽¹⁾	
					M20	1/2 inch NPT	12-pin M23	8-pin Micro (M12) ⁽²⁾
24V AC/DC	3 N.C.	1 N.O.	BBM	GD2 standard	440G-MT47037	440G-MT47039	440G-MT47041	440G-M3NBDH-AC
				Fully flexible	440G-MT47038	440G-MT47040	440G-MT47042	440G-M3NBDH-AC
				—	440G-MT47007	440G-MT47008	440G-MT47043	—
	2 N.C.	2 N.O.	BBM	GD2 standard	440G-MT47044	440G-MT47046	440G-MT47048	—
				Fully flexible	440G-MT47045	440G-MT47047	440G-MT47049	—
				—	440G-MT47010	440G-MT47011	440G-MT47050	—
24V DC with diagnostic function and metal override key	3 N.C.	1 N.O.	BBM	GD2 standard	440G-MT47149	440G-MT47150	440G-MT47151	—
				Fully flexible	440G-MT47152	440G-MT47153	440G-MT47154	—
				No actuator	440G-MT47155	440G-MT47156	440G-MT47157	—
	2 N.C.	2 N.O.	BBM	GD2 standard	440G-MT47158	440G-MT47159	440G-MT47160	—
				Fully flexible	440G-MT47161	440G-MT47162	440G-MT47163	—
				No actuator	440G-MT47164	440G-MT47165	440G-MT47166	—
110V AC/DC	3 N.C.	1 N.O.	BBM	GD2 standard	440G-MT47070	440G-MT47073	—	—
				Fully flexible	440G-MT47071	440G-MT47074	—	—
				—	440G-MT47013	440G-MT47009	—	—
	2 N.C.	2 N.O.	BBM	GD2 standard	440G-MT47077	440G-MT47079	—	—
				Fully flexible	440G-MT47078	440G-MT47080	—	—
				—	440G-MT47012	440G-MT47014	—	—
230V AC/DC	3 N.C.	1 N.O.	BBM	—	440G-MT47016	440G-MT47017	—	—
	2 N.C.	2 N.O.		—	440G-MT47015	440G-MT47024	—	—

(1) For connector ratings, see [Table 23 on page 20](#).

(2) With an 8-pin micro (M12) connector, not all contacts are connected. See [Typical Wiring Diagrams on page 22](#) for wiring details.

Table 22 - Connection Systems

Description	8-pin Micro	12-pin M23
Cordset	889D-F8AB-x ⁽¹⁾	889M-F12AH-x ⁽²⁾
Patchcord	889D-F8ABDM-y ⁽²⁾	889M-F12AHMU-z ⁽³⁾

(1) Replace x with 2 (2 m [6.6 ft]), 5 (5 m [16.4 ft]), or 10 (10 m [32.8 ft]) for standard cable lengths.

(2) Replace y with 1 (1 m [3.3 ft]), 2 (2 m [6.6 ft]), 3 (3 m [9.8 ft]), 5 (5 m [16.4 ft]), or 10 (10 m [32.8 ft]) for standard cable lengths.

(3) Replace z with OM3 (0.3 m [1 ft]), OM6 (0.6 m [2 ft]), 1 (1 m [3.3 ft]), 2 (2 m [6.6 ft]) or 3 (3 m [9.8 ft]) for standard lengths.

Table 23 - Connector Ratings

	Max Ratings		Applicable Standards
	AC	DC	
4-pin Micro (M12)	250V, 4 A	250V, 4 A	IEC 61076-2-101
5-pin Micro (M12)	60V, 4 A	60V, 4 A	IEC 61076-2-101
6-pin Micro (M12)	30V, 2 A	30V, 2 A	IEC 61076-2-101
8-pin Micro (M12)	30V, 2 A	30V, 2 A	IEC 61076-2-101
12-pin M23	63V, 6 A	63V, 6 A	IEC 61984

Accessories

Table 24 - Guard Locking Switch Accessories

Description	Cat. No.	
 GD2 standard actuator	440G-A27011	
 GD2 flat actuator	440K-A11112	
 Fully flexible actuator	440G-A27143	
 Sliding bolt actuator	440G-A27163	
 Extended flat actuator	440K-A17116	
	Replacement cover, no status indicator, no override key	440G-MT47120
	Replacement cover, status indicator, override key	440G-MT47123
 Emergency override key (See following Attention)	440G-A36026	
 Dust cover	440K-A17180	



ATTENTION: Do not attach the emergency override key to the 440G-MT switch.

Approximate Dimensions

Dimensions are not intended to be used for installation purposes.

Figure 11 - Guard Locking Switch [mm (in.)]

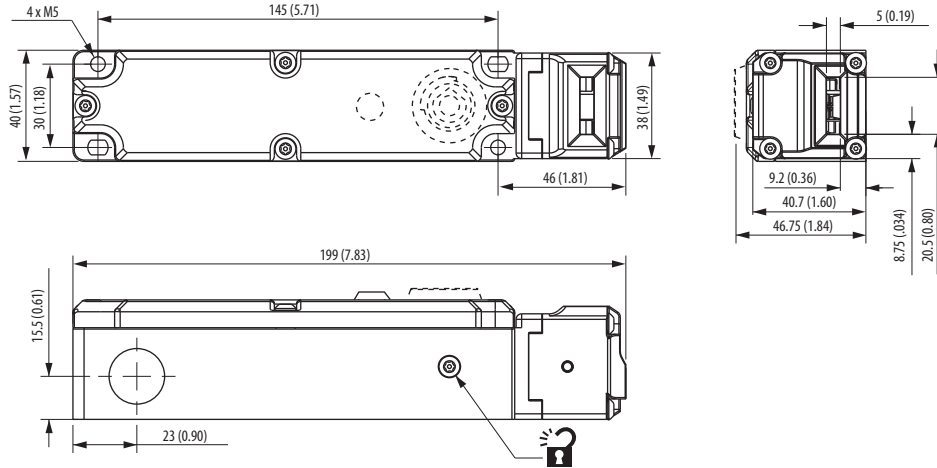

Typical Wiring Diagrams

Table 25 - Guard Locking Switch Wiring

Description	2 N.C. and 2 N.O.	3 N.C. and 1 N.O.																								
Contact Configuration																										
Contact Action □ Open ■ Closed	<p>BBM</p>	<p>BBM</p>																								
8-pin Micro (M12)	—																									
12-pin m23 QD	<table border="1"> <tr> <td>1 and 3</td> <td>Solenoid power</td> </tr> <tr> <td>4 and 6</td> <td>Safety A</td> </tr> <tr> <td>7 and 8</td> <td>Safety B</td> </tr> <tr> <td>2 and 5</td> <td>Aux A</td> </tr> <tr> <td>9 and 10</td> <td>Aux B</td> </tr> <tr> <td>12</td> <td>Ground</td> </tr> </table>	1 and 3	Solenoid power	4 and 6	Safety A	7 and 8	Safety B	2 and 5	Aux A	9 and 10	Aux B	12	Ground	<table border="1"> <tr> <td>1 and 3</td> <td>Solenoid power</td> </tr> <tr> <td>4 and 6</td> <td>Safety A</td> </tr> <tr> <td>7 and 8</td> <td>Safety B</td> </tr> <tr> <td>2 and 5</td> <td>Safety C</td> </tr> <tr> <td>9 and 10</td> <td>Aux A</td> </tr> <tr> <td>12</td> <td>Ground</td> </tr> </table>	1 and 3	Solenoid power	4 and 6	Safety A	7 and 8	Safety B	2 and 5	Safety C	9 and 10	Aux A	12	Ground
1 and 3	Solenoid power																									
4 and 6	Safety A																									
7 and 8	Safety B																									
2 and 5	Aux A																									
9 and 10	Aux B																									
12	Ground																									
1 and 3	Solenoid power																									
4 and 6	Safety A																									
7 and 8	Safety B																									
2 and 5	Safety C																									
9 and 10	Aux A																									
12	Ground																									

Table 25 - Guard Locking Switch Wiring

Description		2 N.C. and 2 N.O.	3 N.C. and 1 N.O.
8-pin Cordset 889D-F8AB-x ⁽¹⁾	Brown Blue	–	Solenoid power
	Gray Red	–	Safety A
	Yellow Pink	–	Safety B
	White Green	–	Aux A
12-pin Cordset 889M-F12AH-x ⁽¹⁾ Gray/pink not connected.	Brown Gray	Solenoid Power	Solenoid Power
	Pink Yellow	Safety A	Safety A
	White Red/Blue	Safety B	Safety B
	Blue Red	Aux A	Safety C
	Black Violet	Aux B	Aux A
	Green	Ground	Ground

(1) Replace x with 2 (2 m [6.6 ft]), 5 (5 m [16.4 ft]), or 10 (10 m [32.8 ft]) for standard cable lengths.

Table 26 - Diagnostic Version

Actuator	Status Indicator Output Matrix	
	Solenoid Off	Solenoid On
In	Green	Amber
Out	Flashing red	Red

Table 27 - Diagnostic Electrical Output

Actuator	Voltage
In	0V DC
Out	+24V DC

Electrical output independent of solenoid status. Maximum output is 100 mA.

Atlas 5 Guard Locking Switches

The Atlas™ 5 guard locking switches have the following features:

- Type 2 interlocking device with guard locking and low coding per ISO 14119
- High F_{zh} (holding force): 3850 N (865 lb)
- Mechanical lock (Power to Release)
- Heavy-duty, die-cast alloy housing for use in harsh environments
- Patented self-aligning head tolerates actuator misalignment



Specifications

Table 28 - Guard Locking Switch Specifications

Attribute	Value	
Safety ratings		
Standards	ISO 14119, IEC 60947-5-1	
Safety classification	Type 2 interlocking device with guard locking and low coding per ISO 14119	
Functional safety	See publication SAFETY-SR001	
Certifications	cULus Listed, TÜV Certified, UKCA Marked for all applicable regulations, and CE Marked for all applicable directives rok.auto/certifications	
Outputs		
Safety contacts	Atlas 5: 2 N.C. direct opening action; 1 N.O. direct opening action Atlas 5 trapped key (left hand): 2 N.C. direct opening action; 1 N.O. direct opening action	
Auxiliary contacts	1 N.O.	
Thermal current/ <i>I_{th}</i>	10 A	
Rated insulation voltage (U _i)	500V	
Switching current at voltage, min	3 mA at 18V DC	
Utilization Category		
AC-15 (U _e)	240V	120V
AC-15 (I _e)	1.5 A	3 A
DC-13 (U _e)	24V	
DC-13 (I _e)	2 A	
Solenoid characteristics		
Locking type	Power to Release	
Holding force F _{max}	5000 N (1124 lbf)	
Holding force F _{zh}	3850 N (865 lbf)	
Power supply	24V AC/DC or 110V AC or 230V AC (solenoid)	
Solenoid power	13 W typical 100% ED	
Operating characteristics		
Break contact force, min	12 N (2.7 lbf)	
Actuation speed, max	160 mm (6.29 in.)/s	
Actuation frequency, max	2 cycles/s	
Operating radius, min	300 mm (11.8 in.) end entry, 800 mm (31.5 in.) front entry	
Mechanical life	1,000,000 operations	
Environmental		
Enclosure type rating	IP65	
Operating temperature	-10...+60 °C (14...140 °F)	
Physical Characteristics		
Material	<ul style="list-style-type: none"> • Housing: Die-cast alloy • Actuator: Stainless steel 	
Weight	1200 g (2.65 lb)	
Color	Red	

Product Selection

Table 29 - Guard Locking Switch Product Selection

Module Type	Actuator Type	Contact		Solenoid Contacts	Solenoid Voltage	Cat. No.			
		Safety	Auxiliary			Conduit Entry ⁽¹⁾			
						M20	1/2 inch NPT Adapter	12-pin M23 ⁽²⁾	8-pin Micro (M12) ⁽²⁾
Standard	Standard	2 N.C.	1 N.O.	2 N.C. and 1 N.O.	24V AC/DC	440G-L07264	440G-L07258	440G-L07298	440G-L2NNSDH-3N
					110V AC/DC	440G-L07263	440G-L07257	–	–
					230V AC/DC	440G-L07262	440G-L07256	–	–
LH Key Lock					24V AC/DC	440G-L07255	440G-L07249	440G-L07301	440G-L2NNSDH-38
					110V AC/DC	440G-L07254	440G-L07248	–	–
					230V AC/DC	440G-L07253	440G-L07247	–	–

(1) For connector ratings, see Safety Switches and Connectors.

(2) With an 8-pin micro connector, not all contacts are connected. See [Typical Wiring Diagrams on page 26](#) for details.

Table 30 - Connection Systems

Description	Cat. No.	
	8-pin Micro (M12)	12-pin M23
Cordset	889D-F8AB-x ⁽¹⁾	889M-F12AH-x ⁽¹⁾
Patchcord	889D-F8ABDM-y ⁽²⁾	889M-F12AHMU-z ⁽³⁾





(1) Replace x with 2 (2 m [6.6 ft]), 5 (5 m [16.4 ft]), or 10 (10 m [32.8 ft]) for standard cable lengths.

(2) Replace y with 1 (1 m [3.3 ft]), 2 (2 m [6.6 ft]), 3 (3 m [9.8 ft]), 5 (5 m [16.4 ft]), or 10 (10 m [32.8 ft]) for standard cable lengths.

(3) Replace z with OM3 (0.3 m [1 ft]), OM6 (0.6 m [2 ft]), 1 (1 m [3.3 ft]), 2 (2 m [6.6 ft]), or 3 (3 m [9.8 ft]) for standard lengths.

Accessories

Table 31 - Guard Locking Switch Accessories

Description	Cat. No.
 Standard actuator	440G-A07136
 Atlas replacement end cap	440G-A07180
 Fully flex actuator	440G-A07269
 Dust cover	440K-A17181

Approximate Dimensions

Dimensions are not intended to be used for installation purposes.

Figure 12 - Guard Locking Switch Dimensions [mm (in.)]

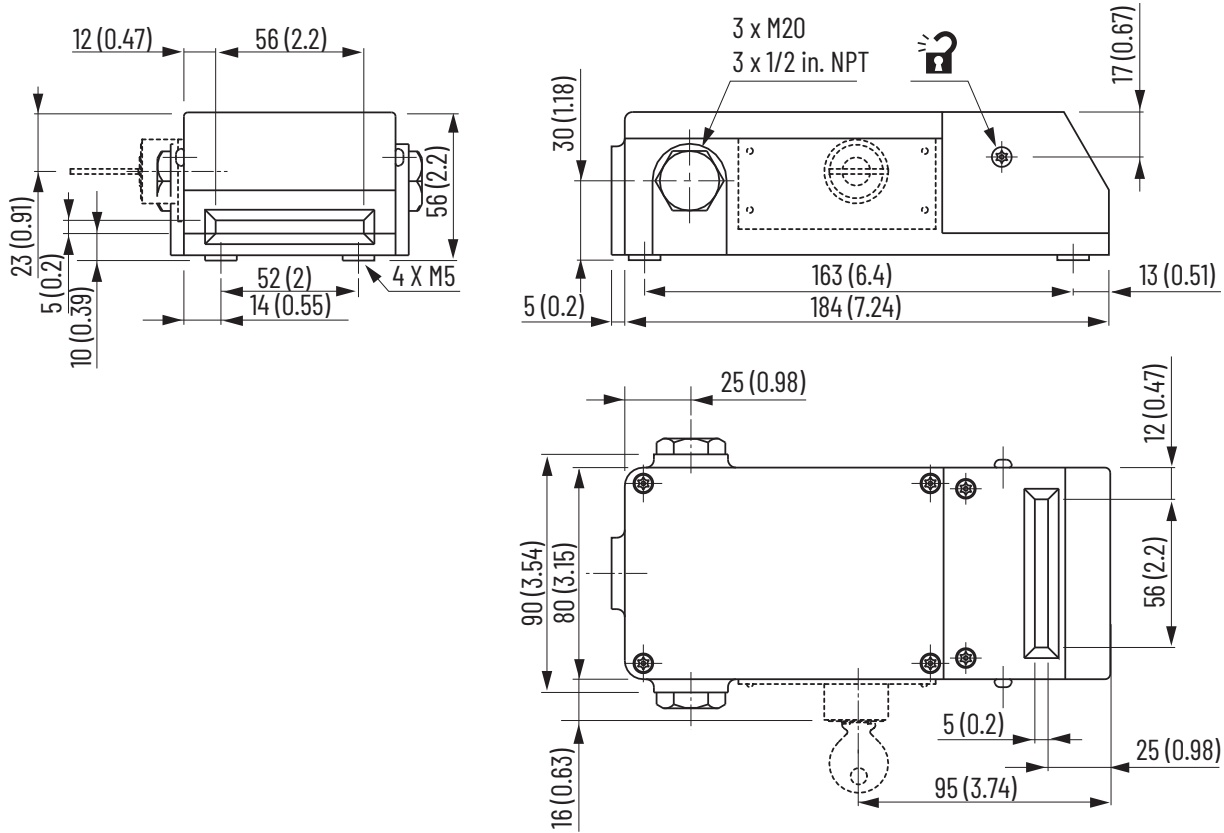

Typical Wiring Diagrams

Figure 13 - Contact Configuration

Guard Open—Solenoid De-energized

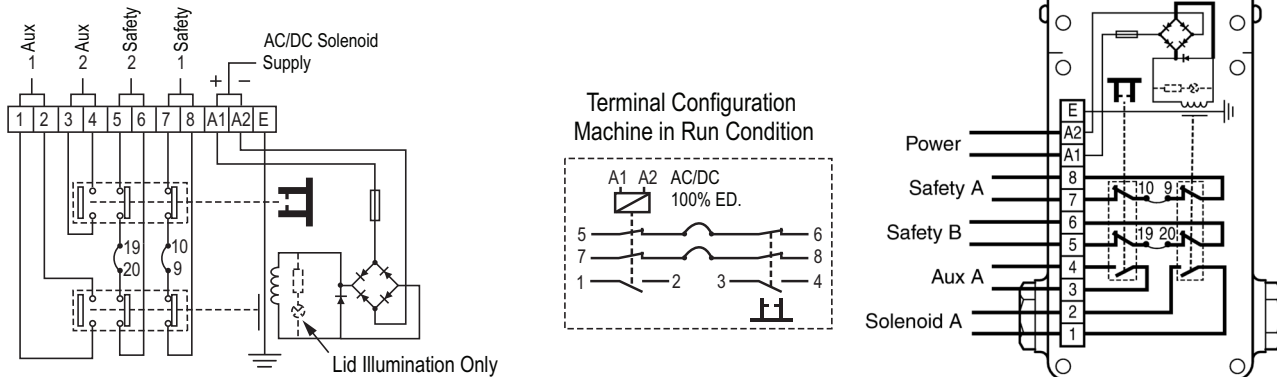
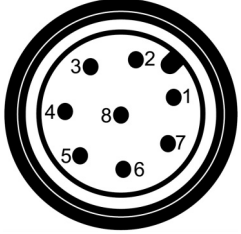

Figure 14 - Contact Action

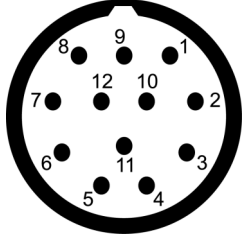

Table 32 - 8-pin (M12) Cordset

889D-F8AB-x ⁽¹⁾	Pin	Color	Function
	1	White/Green	Solenoid A
	2	Brown/Blue	Power
	3	White/Green	Solenoid A
	4	Yellow/Pink	Safety B
	5	Gray/Red	Safety A
	6	Yellow/Pink	Safety B
	7	Brown/Blue	Power
	8	Gray/Red	Safety A

(1) Replace x with 2 (2 m [6.6 ft]), 5 (5 m [16.4 ft]), or 10 (10 m [32.8 ft]) for standard cable lengths.

Table 33 - 12-pin (M23) Cordset

889M-F12AH-x ⁽¹⁾	Pin	Color	Function
	1	Solenoid Power	Brown/Gray
	2	Auxiliary A	Blue/Red
	3	Solenoid Power	Brown/Gray
	4	Safety A	Pink/Yellow
	5	Auxiliary A	Blue/Red
	6	Safety A	Pink/Yellow
	7	Safety B	White/Red/Blue
	8	Safety B	White/Red/Blue
	9	Solenoid A	Black/Violet
	10	Solenoid A	Black/Violet
	11	Not Connected	–
	12	Ground	Green

(1) Replace x with 2 (2 m [6.6 ft]), 5 (5 m [16.4 ft]), or 10 (10 m [32.8 ft]) for standard cable lengths.

440G-S Spartan Guard Locking Switches

The 440G-S Spartan guard locking switches have the following features:

- Type 2 interlock with guard locking and low coding
- Power to Release
- Lid-mounted status indication
- Rotatable head: Four possible key entry slots
- A catch kit with actuator alignment helps protect the unit from actuator damage due to poor guard alignment
- Manual release points with security screws or special key allow the switch to be unlocked if an unforeseen and uncommon circumstance occurs, such as a power failure



Specifications

Table 34 - Guard Locking Switch Specifications

Attribute	Value
Safety Ratings	
Standards	ISO 14119, IEC 60947-5-1
Safety classification	Type 2 interlocking device with guard locking and low coding per ISO 14119
Functional safety	See publication SAFETY-SR001
Certifications	cULus Listed, TÜV Certified, UKCA Marked for all applicable regulations, and CE Marked for all applicable directives rok.auto/certifications
Outputs	
Safety contacts	2 N.C. or 3 N.C. direct opening action
Auxiliary contacts	1 N.O.
Thermal current (I_{th})	10 A
Insulation voltage	500V
Impulse withstand voltage	2500V
Utilization Category	AC 15 500V 250V 100V
AC (Ue)	1 A 2 A 5 A
(Ie)	250V/0.5 A 24V/2 A
DC	
Switched current/volt/load, max	500V/500VA
Current, min	5V 5 mA DC
Safety contact gap	>2 mm (0.08 in.)
Solenoid Characteristics	
Holding force F_{max}	1000 N (225 lb)
Holding force F_{zh}	770 N (173 lb)
Power supply	24V AC/DC, 110V AC, 230V AC (solenoid)
Solenoid power	Typically 7 W 100% ED

Table 34 - Guard Locking Switch Specifications (Continued)

Attribute	Value
Operating Characteristics	
Actuation speed, max	160 mm (6.3 in.) per second
Actuation frequency, max	1 cycle per second
Mechanical life	1,000,000 operations
Environmental	
Pollution degree ⁽¹⁾	3
Operating temperature	-20...+60 °C (-4...+140 °F)
Protection	IP67
Physical Characteristics	
Material	<ul style="list-style-type: none"> • Housing: UL Approved glass filled polyester • Actuator: Stainless Steel
Conduit entry	1 x M20 or quick disconnect style
Fixing	2 x M5
Mounting	Any position
Electrical life	1,000,000 operations
Weight	260 g (0.57 lb)
Color	Red
Operating radius, min	175 mm (6.9 in.)
Status indicator	Solenoid monitor

(1) Conductive pollution occurs, or dry, non-conductive pollution occurs which becomes conductive due to condensation.

Product Selection



Table 35 - Guard Locking Switch Product Section

Actuator	Solenoid Voltage	Contacts		Cat. No.		
		Safety	Aux.	M20 Conduit	M20 Conduit/ 1/2in. Adapter	Quick Disconnect
Standard	24V AC/DC	2 N.C.	1 N.O.	440G-S36001	440G-S36044	440G-S36058
		3 N.C.	–	440G-S36007	440G-S36047	40G-S36059
	110V AC/DC	2 N.C.	1 N.O.	440G-S36003	440G-S36045	440G-S36060
		3 N.C.	–	440G-S36009	440G-S36048	440G-S36061
	230V AC/DC	2 N.C.	1 N.O.	440G-S36005	440G-S36046	440G-S36062
		3 N.C.	–	440G-S36011	–	440G-S36063
	Mating cable					889M-F12X9AE-x ⁽¹⁾

(1) Replace x with 2 (2 m [6.6 ft]), 5 (5 m [16.4 ft]), or 10 (10 m [32.8 ft]) for standard cable lengths.

Accessories

Table 36 - Guard Locking Switch Accessories

	Description	Cat. No.
	Replacement actuator with catch retainer and guide	440G-A36050
	Manual release key	440G-A36026

Approximate Dimensions

Dimensions are not intended to be used for installation purposes.

Figure 15 - Guard Locking Switch [mm (in.)]

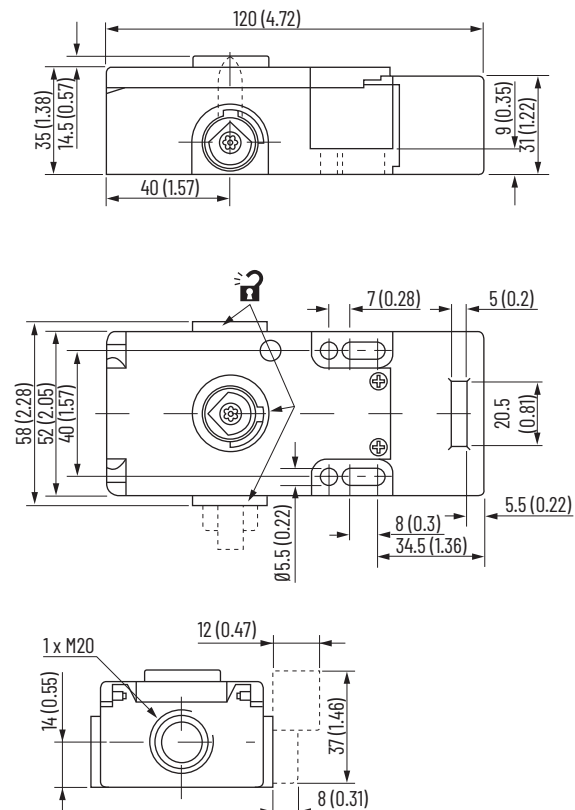

Typical Wiring Diagrams

Table 37 - Guard Locking Switch Wiring

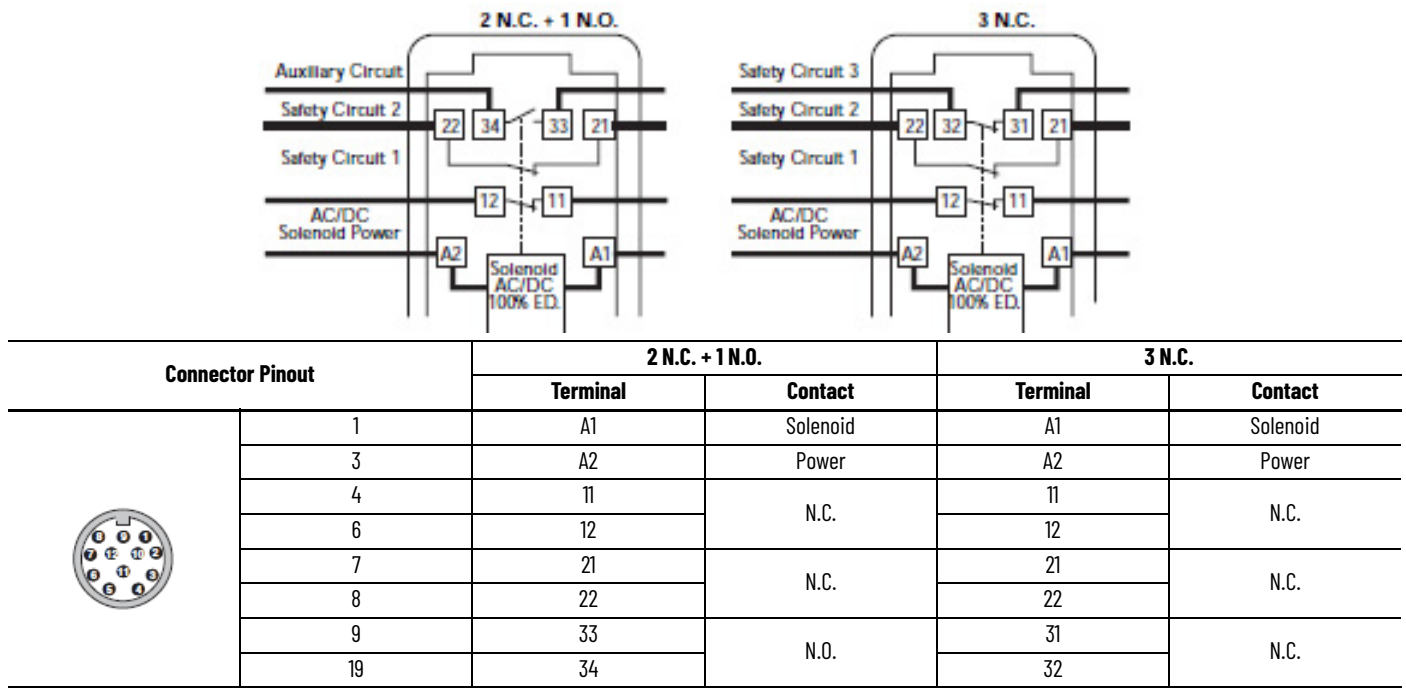

Figure 16 - Contact Action

Contact Action

□ Contact Open ■ Contact Closed

Actuator withdrawal distance from full insertion



Figure 17 - Application Details

Four possible actuator entry positions

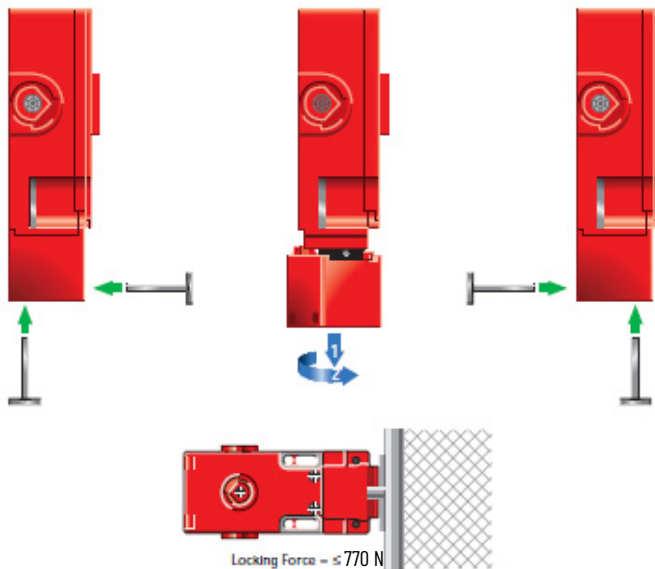

Sprite Miniature Hinge Interlock Switches

The Sprite miniature hinge interlock switches have the following features:

- Ideal for small, light-weight guards
- The smallest hinge interlock switch available, 75 x 25 mm (2.95 x 0.98 in.) case
- Degree of operation can be customized with adjustable cam
- Contacts, 2 N.C. or 1 N.C. and 1 N.O.
- Four possible shaft positions, easy to install



Specifications

Table 38 - Hinge Interlock Switch Specifications

Attribute	Value			
Safety Ratings				
Standards	ISO 14119, 60947-5-1			
Safety classification	Can be suitable for use in Category 3 or Category 4 systems depending on the architecture and application characteristics.			
Functional Safety Data (related to safety contacts) ⁽¹⁾	B10d: > 2 x 10 ⁶ operations at minimum load PFH _d : < 3 x 10 ⁻⁷ MTTFd: > 385 years Can be suitable for use in Performance Level PL _e or PL _d systems (according to ISO 13849-1) and for use in SIL 2 or SIL 3 systems (according to IEC 62061) depending on the architecture and application characteristics			
Certifications	CE Marked for all applicable directives, UKCA Marked for all applicable regulations, cULus Listed, NRTL/C, and TÜV Certified rok.auto/certifications			
Operating Characteristics				
Break contact force, min	8 cN•m (torque on shaft)			
Actuation speed, max	160 mm (6.29 in.)/s			
Actuation frequency, max	1 cycle/s			
Mechanical life	1,000,000 operations			
Utilization Category				
A600/AC-15 (Ue)	600V	500V	240V	120V
A600/AC-15 (Ie)	1.2 A	1.4 A	3 A	6 A
DC-13 (Ue)	24V	—	—	—
DC-13 (Ie)	2 A	—	—	—

Table 38 - Hinge Interlock Switch Specifications (Continued)

Attribute	Value
Outputs	
Safety contacts ⁽²⁾	2 N.C. direct opening action 1 N.C. direct opening action
Auxiliary contacts	— 1 N.O.
Shaft rotation for contact operation	11° max, 3° min (adjustable)
Thermal current/I _{th}	10 A
Rated Insulation voltage U _i	500V
Switching current at voltage, min	3 mA at 18V DC
Environmental	
Enclosure type rating	IP67
Operating temperature	-20...+80 °C (-4...+176 °F)
General	
Material	<ul style="list-style-type: none"> • Housing: UL-approved glass-filled PBT • Actuator: Stainless Steel
Weight	80 g (0.176 lb)
Color	Red

- (1) Usable for ISO 13849-1 and IEC 62061. Data is based on the B10d value that is given and: Usage rate of 1op/10min, 24hr/day, 360 days/year, which represents 51,840 operations per year. Mission time/Proof test interval of 38 years.
- (2) The safety contacts are described as normally closed (N.C.) for example: with the guard closed, actuator in place (where relevant), and the machine able to be started.

Product Selection

Table 39 - Hinge Interlock Switch Product Selection

Contact		Action	Actuator Shaft Dimensions [mm (in.)]	Shaft Type	Cat. No.			
Safety	Auxiliary				M16 Conduit		Connector ⁽¹⁾ (M12)	
					M16	1/2 inch NPT Adapter	4-pin Micro	Connect to ArmorBlock Guard I/O 5-pin Micro
2 N.C.	-	-	80 x Ø10 (3.14 x 0.39)	Solid	440H-S34019	440H-S34023	440H-S34027	-
			60 x Ø8 (2.36 x 0.31)		440H-S34020	440H-S34024	440H-S34028	-
			50 x Ø10 (1.96 x 0.39)		440H-S34010	440H-S34017	440H-S34014	440H-S2NNPPS
			30 x Ø16 (1.18 x 0.63) bore Ø9.5 (0.37)	Pre-bored	440H-S34033	440H-S34034	440H-S34035	440H-S2NNHPS
1 N.C.	1 N.O.	BBM	80 x Ø10 (3.14 x 0.39)	Solid	440H-S34021	440H-S34025	440H-S34029	-
			60 x Ø8 (2.36 x 0.31)		440H-S34022	440H-S34026	440H-S34030	-
			50 x Ø10 (1.96 x 0.39)		440H-S34012	440H-S34018	440H-S34015	-
			30 x Ø16 (1.18 x 0.63) bore Ø9.5 (0.37)	Pre-bored	440H-S34036	-	-	-

(1) For connector ratings, see [Table 41](#).

Table 40 - Connection Systems

Description	Cat. No.		
	4-pin Micro (M12)		5-pin Micro (M12) for ArmorBlock Guard I/O
	2 N.C.	1 N.C. and 1 N.O.	2 N.C.
Cordset	889D-F4AC-x ⁽¹⁾	889D-F4AC-x ⁽¹⁾	-
Patchcord	889D-F4ACDM-y ⁽²⁾	889D-F4ACDM-y ⁽²⁾	889D-F5ACDM-x ⁽¹⁾
Distribution box	889D-4zLT-DM4 ⁽³⁾	889D-4zKT-DM4 ⁽³⁾	-
Shorting plug	889D-41LU-DM	889D-41KU-DM	-
T-port	889D-43LY-D4	889D-43KY-D4	-

(1) Replace x with 2 (2 m [6.6 ft]), 5 (5 m [16.4 ft]), or 10 (10 m [32.8 ft]) for standard cable lengths.

(2) Replace y with 1 (1 m [3.3 ft]), 2 (2 m [6.6 ft]), 3 (3 m [9.8 ft]), 5 (5 m [16.4 ft]), or 10 (10 m [32.8 ft]) for standard cable lengths.

(3) Replace z with 4 or 8 for number of ports.

Table 41 - Connector Ratings

Description	Max Ratings		Applicable Standards
	AC	DC	
4-pin Micro (M12)	250V, 4 A	250V, 4 A	IEC 61076-2-101
5-pin Micro (M12)	60V, 4 A	60V, 4 A	IEC 61076-2-101
6-pin Micro (M12)	30V, 2 A	30V, 2 A	IEC 61076-2-101
8-pin Micro (M12)	30V, 2 A	30V, 2 A	IEC 61076-2-101
12-pin M23	63V, 6 A	63V, 6 A	IEC 61984

Approximate Dimensions

Dimensions are not intended to be used for installation purposes.

Figure 18 - Hinge Interlock Switch Dimensions [mm (in.)]

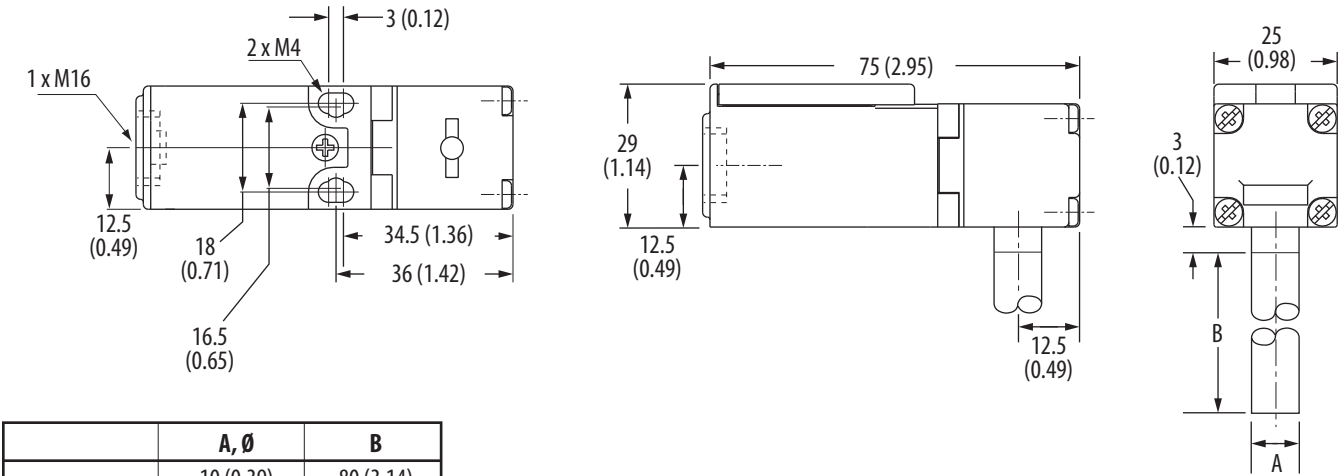
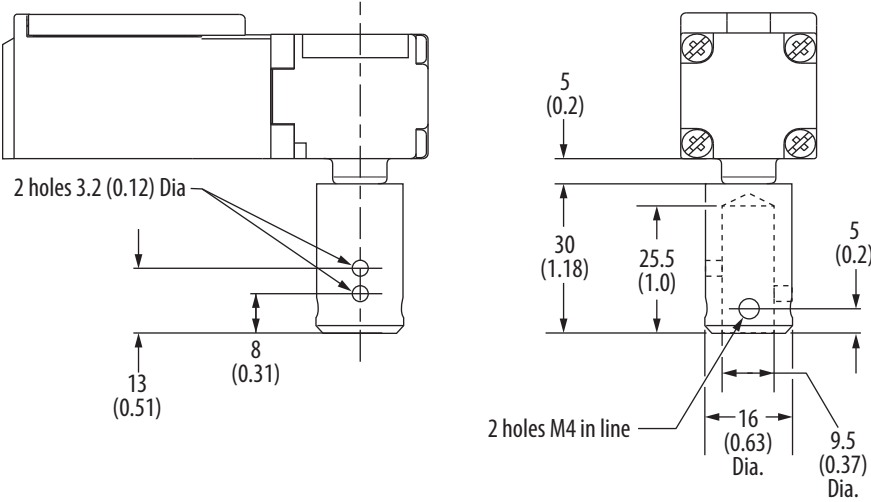

Figure 19 - Hollow Shaft



Typical Wiring Diagrams

Figure 20 - Contact Configuration

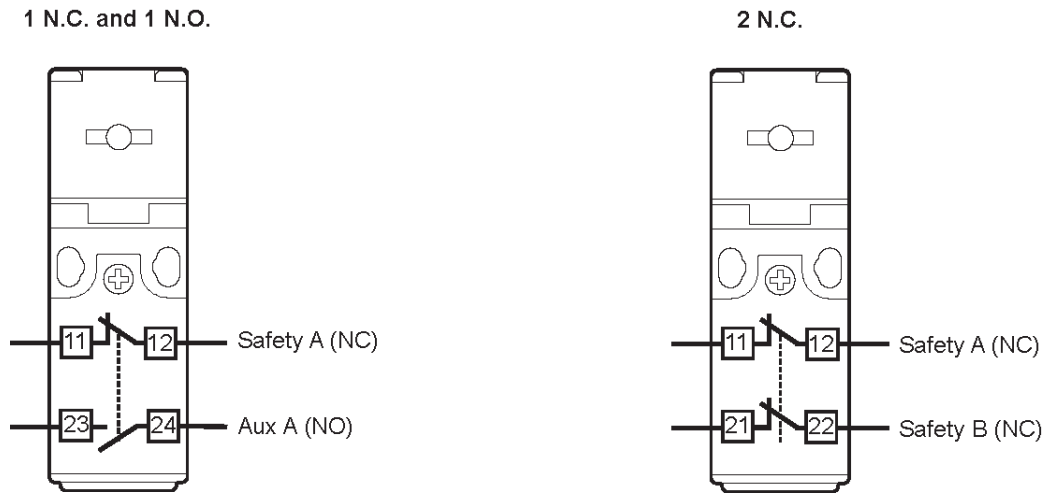

Figure 21 - Contact Action



Figure 22 - 4-pin Micro (M12)

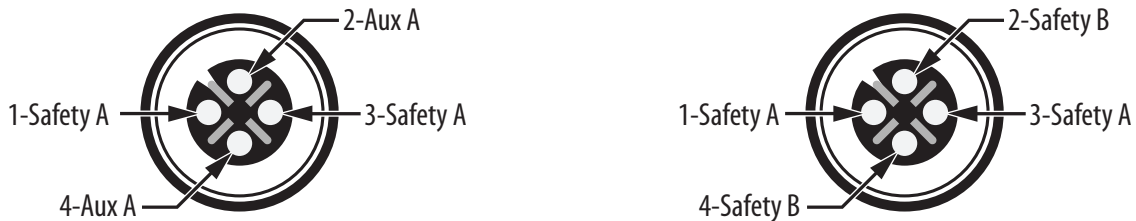

Table 42 - Cordset 889D-F4AC-x⁽¹⁾

Pin	Color	4-pin	
1	Brown	Safety A	Safety A
2	White	Aux A	Safety B
3	Blue	Safety A	Safety A
4	Black	Aux A	Safety B

(1) Replace x with 2 (2 m [6.6 ft]), 5 (5 m [16.4 ft]), or 10 (10 m [32.8 ft]) for standard cable lengths.

Ensign 3 Hinge Interlock Switches

The Ensign 3 hinge interlock switches have the following features:

- Compact size—90.5 x 31 x 30.4 mm (3.56 x 1.22 x 1.2 in.) housing
- Ideal for small, lightweight guards
- Degree of operation can be customized with adjustable cam
- Contacts, 2 N.C. and 1 N.O. or 3 N.C. (sealed to IP67)
- Four possible shaft positions, easy to install
- Solid and hollow shafts available



Specifications

Table 43 - Hinge Interlock Switch Specifications

Attribute	Value			
Safety Ratings				
Standards	ISO 14119, 60947-5-1			
Safety classification	Dual channel interlocks suitable for use in Category 3 or Category 4 systems.			
Functional Safety Data (related to safety contacts) ⁽¹⁾	B10d: > 2 x 10 ⁶ operations at minimum load PFH _D : < 3 x 10 ⁻⁷ MTTFd: > 385 years Can be suitable for use in Performance Level PLe or PLd systems (according to ISO 13849-1) and for use in SIL 2 or SIL 3 systems (according to IEC 62061) depending on the architecture and application characteristics			
Certifications	CE Marked for all applicable directives, UKCA Marked for all applicable regulations, cULus Listed, NRTL/C, and TÜV Certified rok.auto/certifications			
Operating Characteristics				
Break contact force, min	8 cN•m (torque on shaft)			
Actuation speed, max	160 mm (6.29 in.)/s			
Actuation frequency, max	1 cycle/s			
Mechanical life	1,000,000 operations			
Utilization Category				
A600/AC-15 (Ue)	600V	500V	240V	120V
A600/AC-15 (Ie)	1.2 A	1.4 A	3 A	6 A
DC-13 (Ue)	24V	—	—	—
DC-13 (Ie)	2 A	—	—	—
Outputs				
Safety contacts ⁽²⁾	3 N.C. direct opening action	2 N.C. direct opening action		
Auxiliary contacts	—	1 N.O.		
Shaft rotation for contact operation	3 N.C. 12° max, 3° min (adjustable) 2 N.C. 1 N.O. (BBM) 14° max, 5° min (adjustable) 2 N.C. 1 N.O. (MBB) 12° max, 3° min (adjustable)			
Thermal current I _{th}	10 A			
Rated Insulation voltage Ui	500V			
Switching current at voltage, min	3 mA at 18V DC			
Environmental				
Enclosure type rating	IP67			
Operating temperature	-20...+80 °C (-4...+176 °F)			
General				
Material	<ul style="list-style-type: none"> • Housing: UL-approved glass-filled PBT • Actuator: Stainless Steel 			
Weight	100 g (0.22 lb)			
Color	Red			

(1) Usable for ISO 13849-1 and IEC 62061. Data is based on the B10d value that is given and:
 —Usage rate of 1op/10min, 24hr/day, 360 days/year, which represents 51,840 operations per year.
 —Mission time/Proof test interval of 38 years.

(2) The safety contacts are described as normally closed (N.C.) for example: with the guard closed, actuator in place (where relevant), and the machine able to be started.

Product Selection

Table 44 - Hinge Interlock Switch Product Selection

Contact		Action	Actuator Shaft Dimensions [mm (in.)]	Shaft Type	Cat. No.			
Safety	Auxiliary				M20 Conduit		Connector ⁽¹⁾	
					M16	1/2 inch NPT Adapter	6-pin Micro (M12)	Connect to ArmorBlock Guard I/O 5-pin Micro ⁽²⁾
3 N.C.	-	-	80 x Ø10 (3.14 x 0.39)	Solid	440H-E22025	440H-E22050	440H-E22059	-
			60 x Ø8 (2.36 x 0.31)		440H-E22031	440H-E22051	440H-E22060	-
			50 x Ø10 (1.96 x 0.39)		440H-E22047	440H-E22052	440H-E22061	440H-E2NNPPS
			30 x Ø16 (1.18 x 0.63) bore Ø9.5 (0.37)	Pre-bored	440H-E22067	440H-E22068	440H-E22069	440H-E2NNHPS
2 N.C.	1 N.O.	BBM	80 x Ø10 (3.14 x 0.39)	Solid	440H-E22027	440H-E22053	440H-E22037	-
			60 x Ø8 (2.36 x 0.31)		440H-E22033	440H-E22054	440H-E22039	-
			50 x Ø10 (1.96 x 0.39)		440H-E22048	440H-E22055	440H-E22062	-
			30 x Ø16 (1.18 x 0.63) bore Ø9.5 (0.37)	Pre-bored	440H-E22064	440H-E22065	440H-E22066	-
		MBB	80 x Ø10 (3.14 x 0.39)	Solid	440H-E22029	440H-E22056	440H-E22038	-
			60 x Ø8 (2.36 x 0.31)		440H-E22035	440H-E22057	440H-E22040	-
			50 x Ø10 (1.96 x 0.39)		440H-E22049	440H-E22058	440H-E22063	-
			30 x Ø16 (1.18 x 0.63) bore Ø9.5 (0.37)		Pre-bored	440H-E22070	440H-E22071	440H-E22072

(1) For connector ratings, see [Table 41 on page 32](#).

(2) With an 8-pin micro connector, not all contacts are connected. See [Typical Wiring Diagrams on page 38](#) for wiring details.

Table 45 - Connection Systems

Description	Cat. No.	
	6-pin Micro (M12)	5-pin Micro (M12) for ArmorBlock Guard I/O
	3 N.C.-2 N.C. and 1 N.O	3 N.C.
Cordset	889R-F6ECA-x ⁽¹⁾	-
Patchcord	889R-F6ECRM-y ⁽²⁾	889D-F5ACDM-x ⁽¹⁾
Distribution box	898R-P68MT-A5	-
Shorting plug	898R-61MU-RM	-

(1) Replace x with 2 (2 m [6.6 ft]), 5 (5 m [16.4 ft]), or 10 (10 m [32.8 ft]) for standard cable lengths.

(2) Replace y with 1 (1 m [3.3 ft]), 2 (2 m [6.6 ft]), 3 (3 m [9.8 ft]), 5 (5 m [16.4 ft]), or 10 (10 m [32.8 ft]) for standard cable lengths.

Approximate Dimensions

Dimensions are not intended to be used for installation purposes.

Figure 23 - Hinge Interlock Switch [mm (in.)]

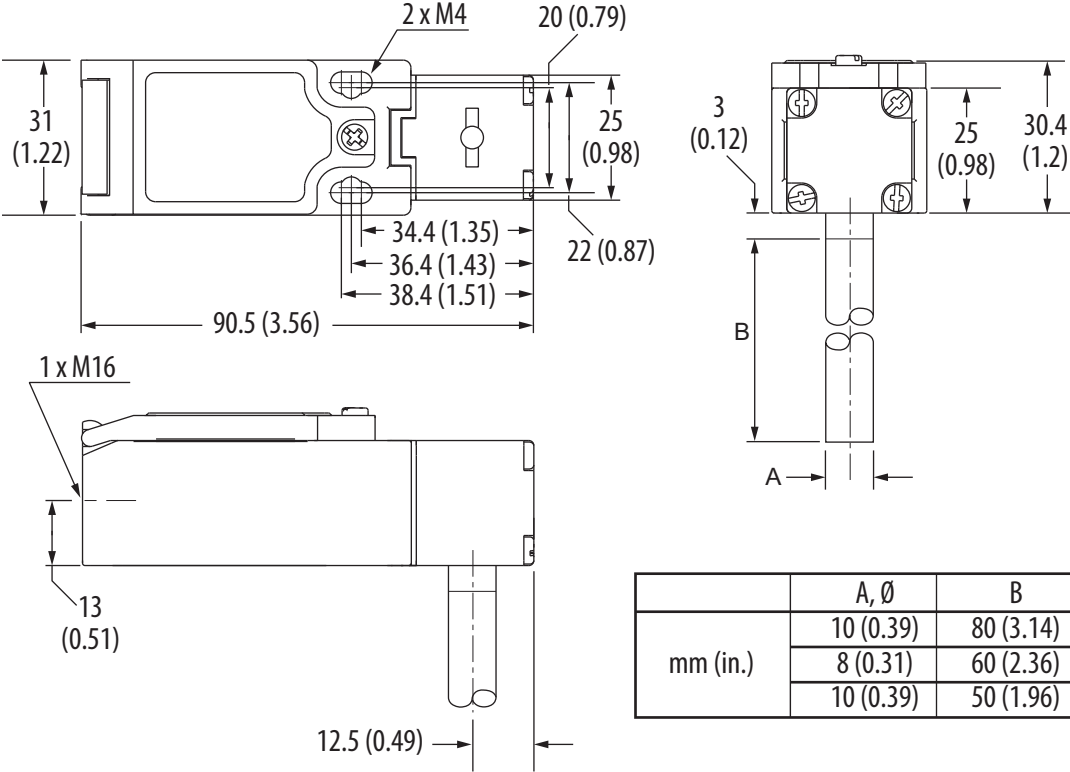
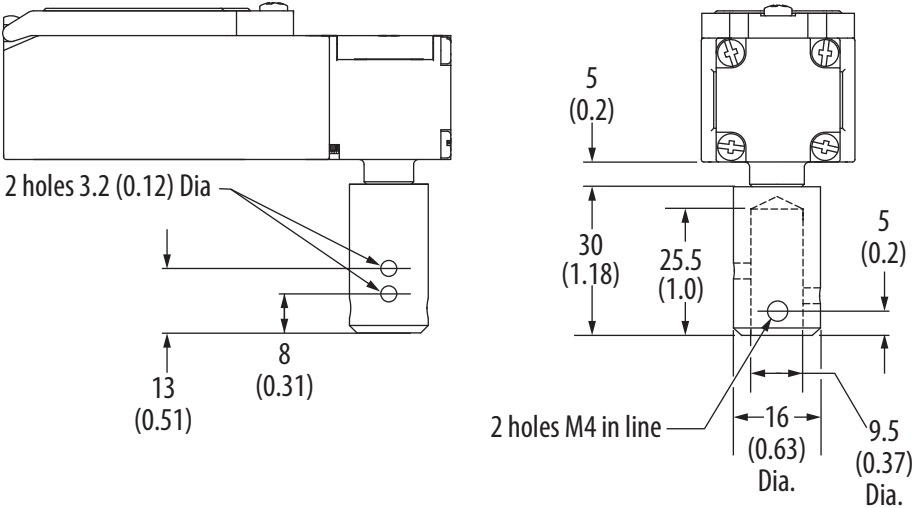

Figure 24 - Hollow Shaft



Typical Wiring Diagrams

Figure 25 - Contact Configuration

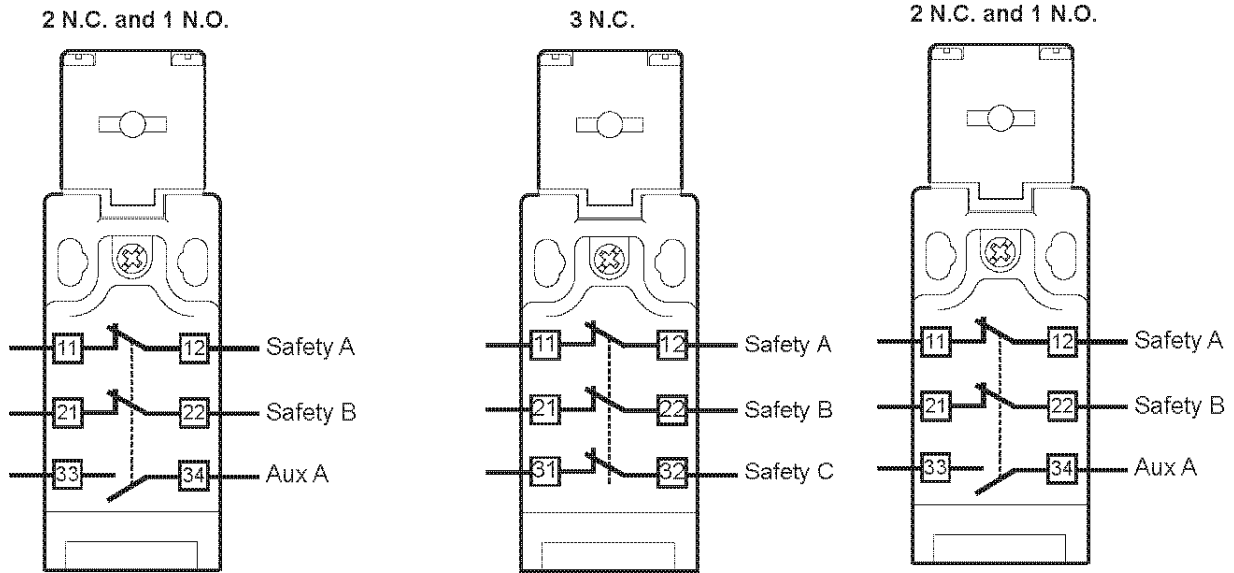

Figure 26 - Contact Action

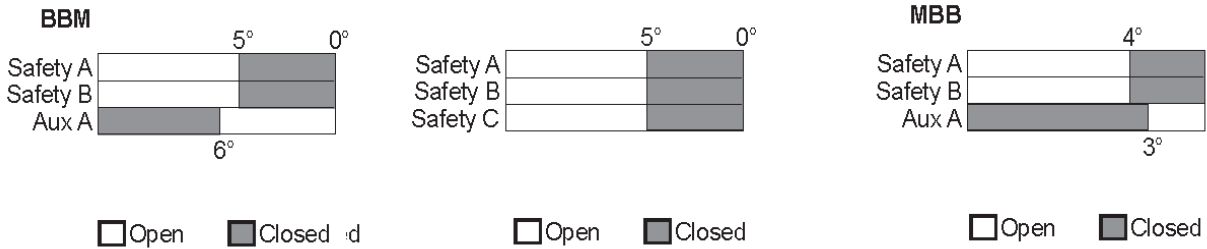
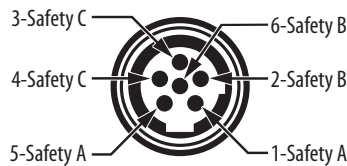
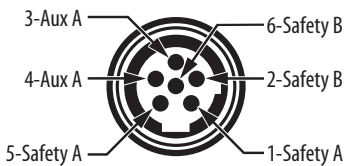

Figure 27 - Connections

6-pin Micro (M12)



5-pin Micro (M12) For ArmorBlock Guard I/O

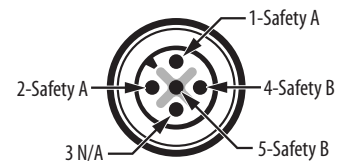

Table 46 - Cordset 889R-F5ECA-x⁽¹⁾ or Cordset 889R-F6ECA-x⁽¹⁾ Cordset 889D-F4AC-x⁽¹⁾

Pin	Color	6-pin	5-pin Micro (M12) For ArmorBlock Guard I/O
1	Red/White	Safety A	Safety A
2	Red	Safety B	Safety A
3	Green	Aux A	—
4	Red/Yellow	Aux A	Safety B
5	Red/Black	Safety A	Safety B
6	Red/Blue	Safety B	—

Pin	Color	5-pin
1	Brown	Safety A
2	White	Safety A
3	—	—
4	Blue	Safety B
5	Black	Safety B

(1) Replace x with 2 (2 m [6.6 ft]), 5 (5 m [16.4 ft]), or 10 (10 m [32.8 ft]) for standard cable lengths.

Rotacam Heavy-duty Hinge Interlock Switches

The Rotacam™ heavy-duty hinge interlock switches have the following features:

- Can be used as a hinge pin on light- and medium-weight guard doors
- Isolates power within 5° of door movement
- Degree of operation can be customized with adjustable cam
- Robust die-cast case, ideal for heavy-duty applications
- Contacts, 2 N.C. and 1 N.O.



Specifications

Table 47 - Hinge Interlock Switch Specifications

Attribute	Value			
Safety Ratings				
Standards	ISO 14119, 60947-5-1			
Safety classification	Dual channel interlocks suitable for use in Category 3 or Category 4 systems.			
Functional Safety Data (related to safety contacts) ⁽¹⁾	B10d: > 2 x 10 ⁶ operations at minimum load PFH _p : < 3 x 10 ⁻⁷ MTTFd: > 385 years Can be suitable for use in Performance Level PL _e or PL _d systems (according to ISO 13849-1) and for use in SIL 2 or SIL 3 systems (according to IEC 62061) depending on the architecture and application characteristics			
Certifications	CE Marked for all applicable directives, UKCA Marked for all applicable regulations, cULus Listed, SUVA, and TÜV Certified rok.auto/certifications			
Operating Characteristics				
Break contact force, min	8 cN•m (torque on shaft)			
Actuation speed, max	160 mm (6.29 in.)/s			
Actuation frequency, max	1 cycle/s			
Mechanical life	1,000,000 operations			
Utilization Category				
A600/AC-15 (Ue)	600V	500V	240V	120V
A600/AC-15 (Ie)	1.2 A	1.4 A	3 A	6 A
DC-13 (Ue)	24V	—	—	—
DC-13 (Ie)	2 A	—	—	—
Outputs				
Safety contacts ⁽²⁾	2 N.C. direct opening action			
Auxiliary contacts	1 N.O.			
Shaft rotation for contact operation	11° max, 5° min (adjustable)			
Thermal current/ <i>I_{th}</i>	10 A			
Rated Insulation voltage U _i	500V			
Switching current at voltage, min	3 mA at 18V DC			
Environmental				
Enclosure type rating	IP66			
Operating temperature	-20...+80 °C (-4...+176 °F)			
General				
Material	<ul style="list-style-type: none"> • Housing: Heavy-duty die-cast alloy • Actuator: Stainless Steel 			
Weight	420 g (0.926 lb)			
Color	Red			

(1) Usable for ISO 13849-1 and IEC 62061. Data is based on the B10d value that is given and:
 –Usage rate of 1op/10min, 24hr/day, 360 days/year, which represents 51,840 operations per year.
 –Mission time/Proof test interval of 38 years.

(2) The safety contacts are described as normally closed (N.C.) for example: with the guard closed, actuator in place (where relevant), and the machine able to be started.

Product Selection

Table 48 - Hinge Interlock Switch Selection

Contact		Action	Actuator Shaft Dimensions [mm (in.)]	Shaft Type	Cat. No.		
Safety	Auxiliary				M20 Conduit		Connector ⁽¹⁾
					M20	1/2 inch NPT Adapter	8-pin Micro (M12)
2 N.C.	1 N.O.	BBM	85 x Ø12.7 (3.35 x 0.5)	Solid	440H-R03079	440H-R03088	440H-R03112
			30x Ø16 (1.18 x 0.63)	Pre-bored	440H-R03074	440H-R03078	440H-R03111

(1) For connector ratings, see [Table 41 on page 32](#).

Table 49 - Connection Systems

Description	Cat. No.
Cordset	889D-F8AB-x ⁽¹⁾
Patchcord	889D-F8ABDM-y ⁽²⁾

(1) Replace x with 2 (2 m [6.6 ft]), 5 (5 m [16.4 ft]), or 10 (10 m [32.8 ft]) for standard cable lengths.

(2) Replace y with 1 (1 m [3.3 ft]), 2 (2 m [6.6 ft]), 3 (3 m [9.8 ft]), 5 (5 m [16.4 ft]), or 10 (10 m [32.8 ft]) for standard cable lengths.

Approximate Dimensions

Dimensions are not intended to be used for installation purposes.

Figure 28 - Hinge Interlock Switch [mm (in.)]

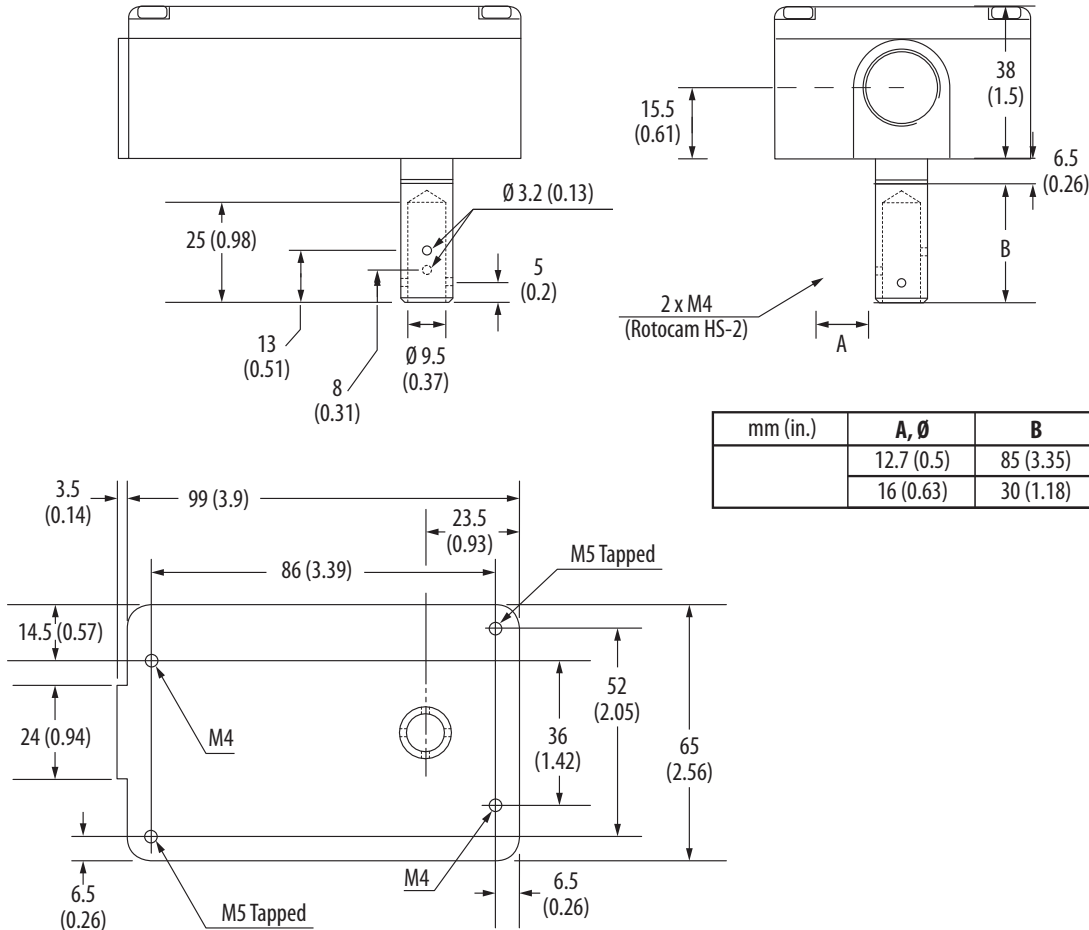

Typical Wiring Diagrams

Figure 29 - Contact Configuration
2 N.C. and 1 N.O.

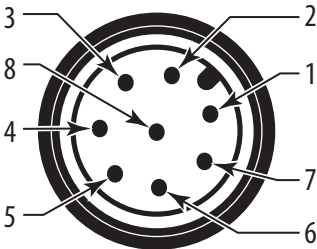
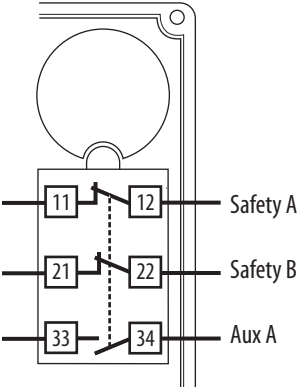

Table 50 - 8-pin (M12) Cordset 889D-F8AB-x ⁽¹⁾

Pin	Color	Description
1	White/Blue	Safety A
2	—	—
3	Green/Yellow	Aux A
4	Green/Yellow	Aux A
5	Gray/Pink	Safety B
6	Gray/Pink	Safety B
7	White/Blue	Safety A
8	Red	Ground

(1) Replace x with 2 (2 m [6.6 ft]), 5 (5 m [16.4 ft]), or 10 (10 m [32.8 ft]) for standard cable lengths.

Notes:

440G-EZ Electromagnetic Safety Switches

The 440G-EZ electromagnetic safety switches have the following features:

- Process and machine protection per ISO 14119
- Certified to PLe per ISO 13849-1 (for door position monitoring)
- Non-contact interlocking device with a Power to Lock (PTL) electromagnetic locking function for process protection
- Switches can be connected in series
- Sensor can be mounted in either a surface mount or a flush mount
- Ease of installation and alignment; no tongue interlocks
- Increased efficiency and productivity by minimized downtime
- Reduced long-restart delays
- Status indicators for switch and lock status
- High tolerance to door offset within 5 mm (0.2 in.) in all directions
- Reduced accumulation of scrap



Specifications

Table 51 - Safety Switch Specifications

Attribute	440G-EZS21STL05J, 440G-EZS21STL05H, 440G-EMAS
Safety Ratings	
Standards	ISO 14119, IEC 60947-5-3, ISO 13849-1, IEC 62061
Safety classification: Guard position sensing	Type 4 interlocking device with guard locking per ISO 14119 PLe category 4 per ISO 13849-1 and SIL 3 per IEC 62061
Functional Safety Data (door position monitoring)	PFH: 1.5 x 10 ⁻⁸ (EN ISO 13849). Mission time/PTI: 20 years
Certifications	CE marked for all applicable EU directives, UKCA Marked for all applicable regulations, cULus (UL508) Listed, TÜV Certified, and RCM rok.auto/certifications
Operating Characteristics	
Safe switch on distance	4 mm (0.16 in.)
Typical switch on distance	15 mm (0.59 in.)
Safe switch off distance	45 mm (1.77 in.)
Holding force	500 N
Retaining force	25 N
Actuation frequency, max	0.5 Hz
Alignment tolerance for locking device	<ul style="list-style-type: none"> • Vertical: 5 mm (0.2 in.) • Horizontal: 5 mm (0.2 in.)
Aperture angle	3°
Offset tolerance	5 mm (0.2 in.)
Rated voltage	24V DC
Insulation voltage U _i	32V
Rated impulse withstand voltage U _{imp}	1.5 kV
Supply voltage when an individual safety switch is connected	24V DC (19.2...28.8 V DC)
Supply voltage UV when a cascade is connected	<ul style="list-style-type: none"> • Sensor: 24V DC (22.8...28.8 V DC) • Magnet: 24V DC (21.6...28.8 V DC)
Power consumption	<ul style="list-style-type: none"> • Locking active: 350 mA • Locking deactivated: 50 mA
Switching frequency	≤0.5 Hz

Table 51 - Safety Switch Specifications (Continued)

Attribute	440G-EZS21STL05J, 440G-EZS21STL05H, 440G-EMAS
Type of output	OSSD
Output current, max	≤100 mA
Diagnostic output	≤25 mA, short-circuit protected
Cable capacitance	400 nF (for OUT A and OUT B)
Response time	50 ms
Enable time	100 ms
Risk time	100 ms
Power up delay	2.5 s
Muting time when supply voltage is interrupted	4 ms
Environmental	
Operating temperature	-20...+55 °C (-4...+131 °F)
Storage temperature	-25...+55 °C (-4...+131 °F)
Relative humidity	50% at 70C (IEC 60947-5-2)
Enclosure ingress rating	IP67
Shock and vibration	IEC EMC: EN IEC 61326-3-1, EN IEC 60947-5-2, EN IEC 60947-5-3
Outputs	
Safety outputs	2 x OSSDs, 2 x PNP, max 100 mA, short-circuit protected and overload-proof
Auxiliary output	25 mA max, short-circuit protected (resistive load)
Switching voltage	<ul style="list-style-type: none"> • ON State: 19.2...28.8 V DC • OFF State: 0...2 V DC
Switching current	<ul style="list-style-type: none"> • ON State: ≤100 mA • OFF State: ≤500 μA
Shock and vibration	300 μs
Physical Characteristics	
Material	<ul style="list-style-type: none"> • Sensor: Anodized aluminum • Actuator: Fiberglass-reinforced PVC • Anchor plate: Nickel-plated steel
Weight	<ul style="list-style-type: none"> • Sensor: 510 g (18 oz) • Actuator: 210 g (7.4 oz)

Product Selection

Table 52 - Safety Switch Product Selection

Description	Cat. No.
5-pin electromagnetic safety switch	440G-EZS21STL05J
8-pin electromagnetic safety switch	440G-EZS21STL05H

Accessories

Table 53 - Safety Switch Accessories

Description	Cat. No.
Replacement actuator	440G-EMAS

Approximate Dimensions

Dimensions are not intended to be used for installation purposes.

Figure 30 - Actuator [mm (in.)]

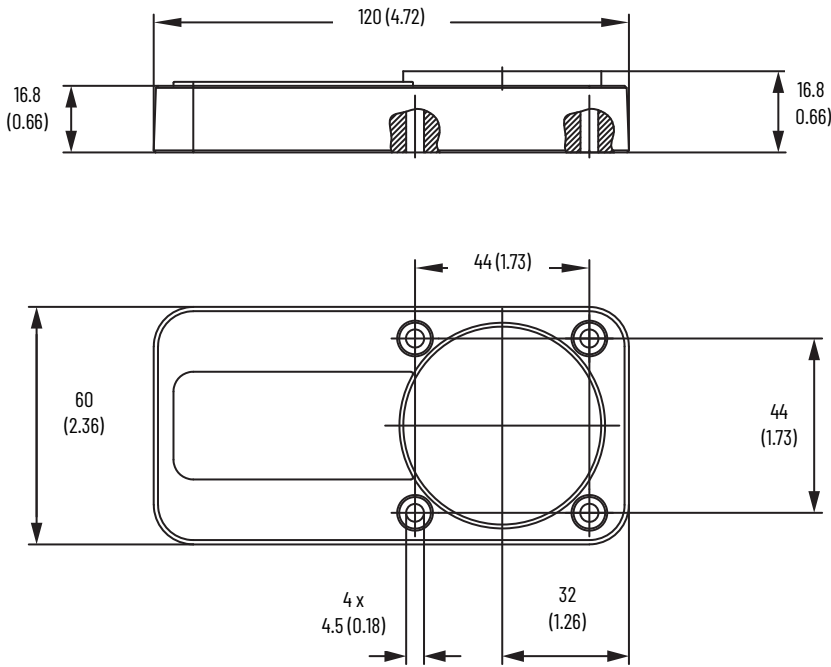
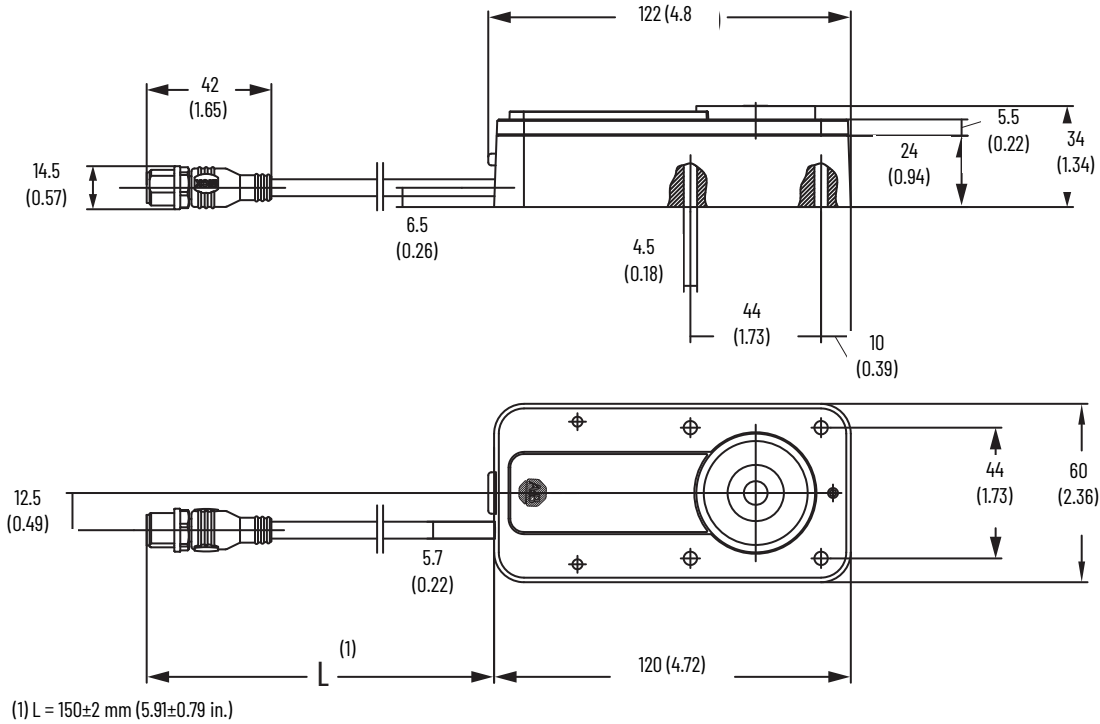
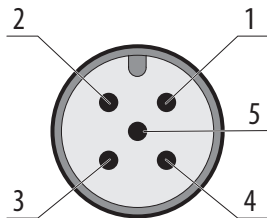

Figure 31 - Sensor [mm (in.)]



Typical Wiring Diagrams

Table 54 - Device Connection Pin Assignment (Convex, M12, 5-pin, A-coded)



Pin	Wire Color ⁽¹⁾	Designation	Description
1	Brown	+24V DC	Safety switch voltage supply
2	White	OSSD 1	OSSD 1 output
3	Blue	0V	0V DC voltage supply
4	Black	OSSD 2	OSSD 2 output
5	Gray	Magnet	Magnet activation 24V DC

(1) Applies to the extension cables recommended as accessories.

IMPORTANT Pay attention to the tightness of the plug connector.

Table 55 - Device Connection Pin Assignment (Convex, M12, 8-pin, A-coded)

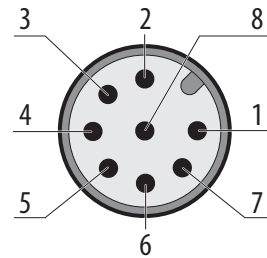

Pin	Wire Color ⁽¹⁾	Designation	Description
1	White	Aux	Application diagnostic output (not safe)
2	Brown	+24V DC	Safety switch voltage supply
3	Green	Magnet	Magnet activation 24V DC
4	Yellow	In 2	OSSD 2 input ⁽²⁾
5	Gray	OSSD 1	OSSD 1 output
6	Pink	OSSD 2	OSSD 2 output
7	Blue	0V	0V DC voltage supply
8	Red	In 1	OSSD 1 input

(1) Applies to the extension cables recommended as accessories.

(2) When used as an individual safety switch or as the first safety switch in a cascade apply 24V DC.

IMPORTANT Pay attention to the tightness of the plug connector.

SensaGuard Non-contact Interlock Switches

The SensaGuard™ non-contact interlock switches have the following features:

- Category 4, SIL 3 rated switch, TÜV functional safety approved to IEC 61508
- Switches can be connected to a standard safety relay, for example, the MSR126, MSR127, SmartGuard™, and Safety I/O Blocks
- Multiple actuator sizes for large sensing distance
- IP69K environmental rating
- Short-circuit and overvoltage protection
- Status indicator on the switch for door status and troubleshooting
- Unique coded version
 - Automatic learn process at unit power-up
 - During commissioning, you can select if the sensor can learn a new actuator up to eight times or lock the unit so it cannot learn another actuator
- Integrated latch version
 - Adjustable magnetic force 15...45 N
 - Designed for easy mounting on aluminum profile



The SensaGuard non-contact interlock switches offer the following benefits:

- No dedicated controller required
- Cat 4, SIL 3 rating maintained even with multiple units connected in series
- Switches can be connected in series with other devices (light curtain, E-stops, key interlock switches)
- Extended diagnostics for easy troubleshooting
- Large sensing distances
- Tolerance to misalignment
- Multiple sensing directions
- Stainless-steel version suitable for use in harsh environments
- Use standard proximity brackets

Specifications

Table 56 - Interlock Switch Specifications

Attribute	Value
Safety Ratings	
Standards	ISO 14119, IEC 60947-5-3, IEC 61508, ISO 13849-1, IEC 62061
Safety classification	Type 4 Interlocking Device per ISO 14119 (Unique/High and Standard/Low Coding), PLe category 4 per ISO 13849-1
Functional safety data	See publication SAFETY-SR001
Certifications	cULus (UL 508) Listed, TÜV Certified, UKCA Marked for all applicable regulations, and CE Marked for all applicable directives rok.auto/certifications
Outputs (Guard Door Closed, Actuator in Place)	
Safety outputs	2 x PNP, 0.2 A, max; Status: ON (+24V DC)
Auxiliary outputs	1 x PNP, 0.2 A max; Status: OFF (0V DC)
Operating Characteristics	
Assured sensing distance	<ul style="list-style-type: none"> • 18 mm (0.71 in.) plastic barrel/18 mm (0.71 in.) target: 15 mm (0.59 in.) • 18 mm (0.71 in.) plastic barrel/30 mm (1.18 in.) target: 25 mm (0.98 in.) • 18 mm (0.71 in.) stainless steel barrel/standard target: 10 mm (0.39 in.) • Large rectangular flat pack/standard target: 15 mm (0.59 in.)

Table 56 - Interlock Switch Specifications (Continued)

Attribute	Value
Misalignment tolerance, min	See Magnetically Coded Non-contact Interlock Switches on page 51
Repeat accuracy	10% of Sensing Range
Output current, max	200 mA (all outputs)
Operating voltage	24V DC, +10%/-15%; Class 2
Current consumption	50 mA
Frequency of operating cycle	1 Hz
Response time (off)	54 ms
Environmental	
Enclosure type rating	NEMA 3, 4X, 12, 13, IP69K
Operating temperature	-10...+55 °C (14...131 °F)
Relative humidity	5...95%
Shock	IEC 68-2-27, 30 g, 11 ms
Vibration	IEC 68-2-6 10...55 Hz
Radio frequency	IEC 61000-4-3, IEC 61000-4-6
Physical Characteristics	
Material	<ul style="list-style-type: none"> • Housing: VALOX DR 48 • Actuator: VALOX DR 48
Color	Red

Product Selection

Table 57 - Interlock Switch Product Selection

Type	Assured Sensing Distance [mm (in.)]	Light-emitting Diode (LED) Door Indication/Diagnostic	Margin Indication	Magnetic Hold	Actuator Code Type	Cat. No.			
						Cable		Connector	
						3 m (9.8 ft)	10 m (32.8 ft)	6 in. (152.4 in.) Pigtail, 8-pin Micro (M12)	6 in. (152.4 in.) Pigtail, 5-pin Micro (M12)
18 mm (0.71 in.) plastic barrel/ 18 mm (0.71 in.) actuator	15 (0.59)	Yes	—	—	Standard	440N-Z21S16A	440N-Z21S16B	440N-Z21S16H	440N-Z21S16J
					Unique	440N-Z21U16A	440N-Z21U16B	440N-Z21U16H	440N-Z21U16J
18 mm (0.71 in.) plastic barrel/ 30 mm (1.18 in.) actuator	25 (0.98)	Yes	—	—	Standard	440N-Z21S26A	440N-Z21S26B	440N-Z21S26H	440N-Z21S26J
					Unique	440N-Z21U26A	440N-Z21U26B	440N-Z21U26H	440N-Z21U26J
18 mm (0.71 in.) stainless-steel barrel/ 18 mm stainless-steel actuator	10 (0.39)	Yes	—	—	Standard	440N-Z21S17A	440N-Z21S17B	440N-Z21S17H	440N-Z21S17J
					Unique	440N-Z21U17A	440N-Z21U17B	440N-Z21U17H	440N-Z21U17J
Plastic rectangular/ rectangular actuator	15 (0.59)	Yes	—	—	Standard	440N-Z21SS2A	440N-Z21SS2B	440N-Z21SS2H	440N-Z21SS2J
					Unique	440N-Z21US2A	440N-Z21US2B	440N-Z21US2H	440N-Z21US2J
			Yes	—	Standard	440N-Z21SS2AN	440N-Z21SS2BN	440N-Z21SS2HN	440N-Z21SS2JN
					Unique	440N-Z21US2AN	440N-Z21US2BN	440N-Z21US2HN	440N-Z21US2JN
			Yes	Yes (9 N)	Standard	440N-Z21SS2AN9	440N-Z21SS2BN9	440N-Z21SS2HN9	440N-Z21SS2JN9
					Unique	440N-Z21US2AN9	440N-Z21US2BN9	440N-Z21US2HN9	440N-Z21US2JN9
Plastic housing with integrated latch	Contact/latched	Yes	—	Adjustable 20...60 N	Standard	440N-Z21SS3PA	440N-Z21SS3PB	440N-Z21SS3PH	440N-Z21SS3PJ
					Unique	440N-Z21SU3PA	440N-Z21SU3PB	440N-Z21SU3PH	440N-Z21SU3PJ

Table 58 - Connection Systems

Description	Cat. No.
Cordset	5-pin 889D-F5AC-x ⁽¹⁾
	8-pin 889D-F8AB-x ⁽¹⁾
Patchcord	4-pin 889D-F4ACDM-y ⁽²⁾
	5-pin 889D-F5ACDM-y ⁽²⁾
	8-pin 889D-F8ABDM-y ⁽²⁾
Safety wired t-port	898D-438Y-D8
Safety wired shorting plug	898D-418U-DM
Safety wired shorting plug, 4-pin	898D-41KU-DM

(1) Replace the x with 2 (2 m [6.6 ft]), 5 (5 m [16.4 ft]), or 10 (10 m [32.8 ft]) for standard cable lengths.

(2) Replace the y with 1 (1 m [3.3 ft]), 2 (2 m [6.6 ft]), 3 (3 m [9.8 ft]), 5 (5 m [16.4 ft]), or 10 (10 m [32.8 ft]) for standard lengths.

Accessories

Table 59 - Interlock Switch Accessories

Description	To Be Used With	Cat. No.
	Standard coded models only	440N-Z18PT
	Unique coded models only	440N-Z18UPT
	Standard coded models only	440N-Z18PTB
	Unique coded models only	440N-Z18UPTB
	Standard coded models only	440N-Z30PT
	Unique coded models only	440N-Z30UPT
	Standard coded models only	440N-Z30PTB
	Unique coded models only	440N-Z30UPTB
	Standard coded models only	440N-Z18SST
	Unique coded models only	440N-Z18USST
	Standard coded models only	440N-Z18SSTB
	Unique coded models only	440N-Z18USSTB
	Standard coded models only	440N-ZPREC
	Unique coded models only	440N-ZUPREC
	Standard coded margin/magnetic hold models only	440N-ZPRECM
	Unique coded margin/magnetic hold models only	440N-ZUPRECM
	Standard coded margin indication models	440N-ZPRECM
	Unique coded margin indication models	440N-ZUPRECM

Table 59 - Interlock Switch Accessories (Continued)

Description	To Be Used With	Cat. No.
	Standard coded models only	440N-ZPRECB
	Unique coded models only	440N-ZUPRECB
	Standard coded margin/magnetic hold models only	440N-ZPRECMB
	Unique coded margin/magnetic hold models only	440N-ZUPRECB
	Standard coded margin indication models	440N-ZPRECB
	Unique coded margin indication models	440N-ZUPRECB
	18 mm (0.71 in.) barrel models	871A-BRS18
		871A-BP18
		871A-SCBP18
		60-2649
	Integrated latch version only	440N-AHDB
		440N-ASDB
	18 mm (0.71 in.) barrel models	871A-BRS18

Approximate Dimensions

Dimensions are not intended to be used for installation purposes.

Figure 32 - 18 mm (0.71 in.) Barrel [mm (in.)]

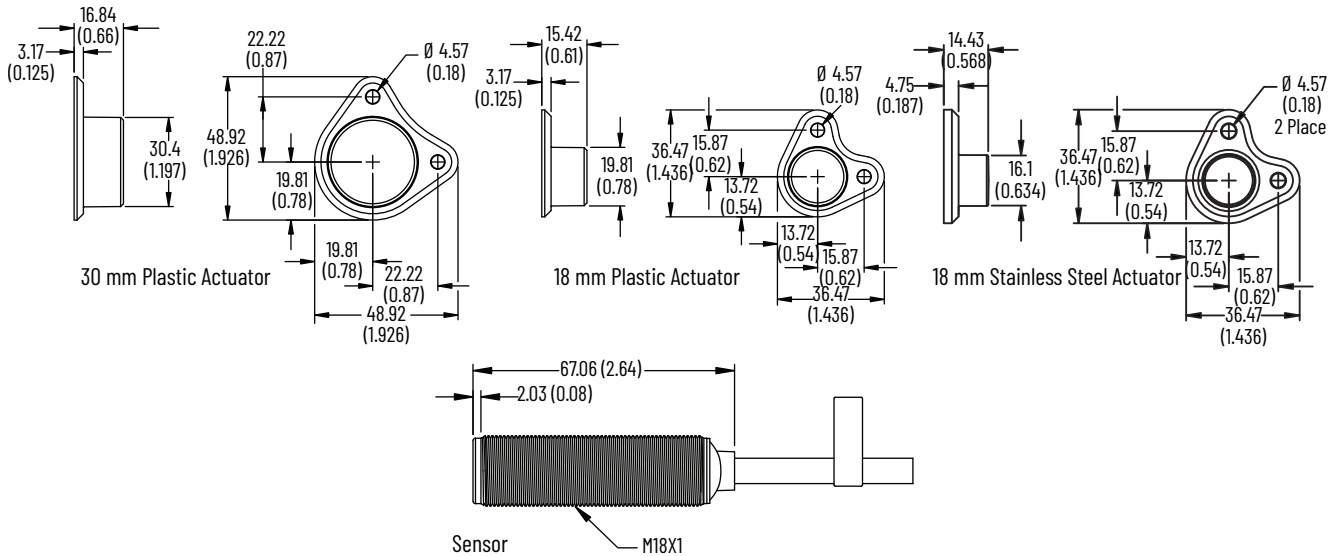

Figure 33 - Large Rectangular Flat Pack [mm (in.)]

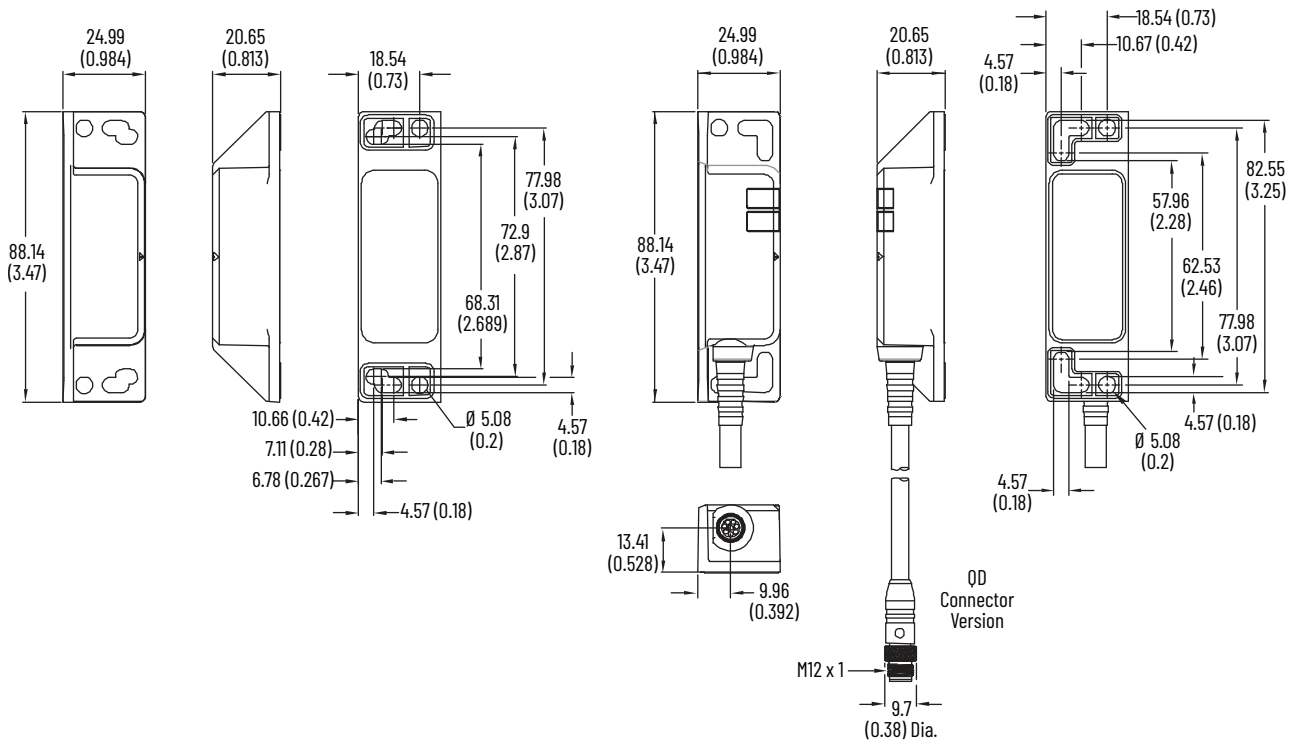
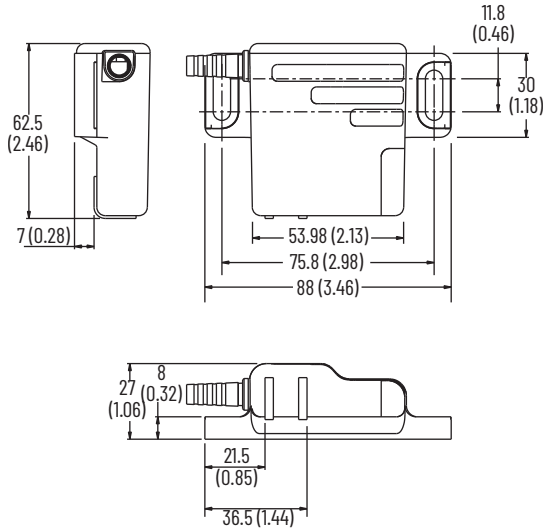

Figure 34 - Integrated Latch [mm (in.)]



Typical Wiring Diagrams

Table 60 - 8-pin Micro (M12)

Description		Plastic	Stainless Steel
8-pin cordset 889D-F8AB-x or cable version ⁽¹⁾	Gray	Safety A	Safety A
	Red	Safety A+	Safety A+
	Pink	Safety B	Safety B
	Yellow	Safety B+	Safety B+
	White	Aux A	Aux A
	Brown	24V DC +	24V DC +
	Blue	Gnd	Gnd
	Green	—	—

(1) Replace x with 2 (2 m [6.6 ft]), 5 (5 m [16.4 ft]), or 10 (10 m [32.8 ft]) for standard cable lengths.

Table 61 - 5-pin Micro (M12)



Pin	Color	Signal
1	Brown	+24V
2	White	Safety OSSD 1 output
3	Blue	0V
4	Black	Safety OSSD 2 output
5	Gray	Auxiliary output

Magnetically Coded Non-contact Interlock Switches

The magnetically coded non-contact interlock switches have the following features:

- Non-contact actuation
- Magnetically coded sensing
- High tolerance to misalignment
- Designed for use with specified controllers



Specifications

Table 62 - Interlock Switch Specifications

Attribute	Value
Safety Ratings	
Standards	ISO 14119, IEC 60947-5-3, ISO 13849-1, IEC 62061
Safety classification	Type 4 Interlocking Device with low coding per ISO 14119
Functional safety data	See publication SAFETY-SR001
Certifications	cULus Listed, TÜV Certified, UKCA Marked for all applicable regulations, and CE Marked for all applicable directives rok.auto/certifications
Outputs (Guard Door Closed, Actuator in Place)	
Safety outputs	<ul style="list-style-type: none"> • MC1: 2 N.C. REEDS • MC2: 2 N.C. solid-state relays
Auxiliary outputs	<ul style="list-style-type: none"> • MC1: – • MC2: 1 x PNP, 0.2 A max; Status: OFF (0V DC)
Operating Characteristics	
Operating distance, make	<ul style="list-style-type: none"> • MC1: 8 mm (0.3 in.) • MC2: 10 mm (0.39 in.)
Operating distance, break	<ul style="list-style-type: none"> • MC1: 15 mm (0.59 in.) • MC2: 25 mm (0.98 in.)
Repeat accuracy	10% of sensing range
Output current, max	200 mA
Switching current at voltage	<ul style="list-style-type: none"> • MC1: 24V DC at 200 mA, max • MC2: 24V DC at 200 mA +10%/-15%, max
Operating voltage/power supply	<ul style="list-style-type: none"> • MC1: – • MC2: 24V DC, +10%/-15%/50 mA max/Class 2 SELV
Frequency of operating cycle	1 Hz
Environmental	
Enclosure type rating	MC1: IP67 (NEMA 6P) MC2: IP69K
Operating temperature	-10...+55 °C (14...131 °F)
Relative humidity	5...95%
Shock	IEC 68-2, 27, 30 g, 11 ms
Vibration	IEC 68-2-6, 10...55 Hz
Radio frequency	IEC 61000-4-3, IEC 61000-4-6
Physical Characteristics	
Material	MC1 <ul style="list-style-type: none"> • Housing: Molded ABS • Actuator: Molded ABS MC2 <ul style="list-style-type: none"> • Housing: Ultrador • Actuator: Ultrador
Color	Red

Product Selection

Table 63 - Interlock Switch Product Selection

Type	Operating Voltage/ Input Current	Safety Outputs	Auxiliary Outputs	Status Indicator	Connection	Cat. No.
MC1	—	2 N.C. REEDS	—	No	4-pin Micro (M12)	440N-Z2NRS1C
					3 m (9.8 ft) cable	440N-Z2NRS1A
					10 m (32.8 ft) cable	440N-Z2NRS1B
MC2	24V DC, +10%/15%/50 mA, max	2 N.C. solid-state relays	1 x PNP, 0.2 A max; Status: OFF (0V DC)	Yes	8-pin Micro (M12)	440N-Z21W1PH
					3 m (9.8 ft) cable	440N-Z21W1PA
					10 m (32.8 ft) cable	440N-Z21W1PB

Table 64 - Connection Systems

Description	Cat. No.	
	Connection to Distribution Box 4-pin Micro (M12) 2 N.C.	8-pin Micro (M12) 2 N.C. and 1 N.O.
Cordset	889D-F4AC-x ⁽¹⁾	889D-F8AB-x ⁽¹⁾
Patchcord	889D-F4ACDM-y ⁽²⁾	889D-F8ABDM-y ⁽²⁾
Distribution box	898D-4zLT-DM4 ⁽³⁾	—
Shorting plug	898D-41LU-DM	—
T-port	898D-43LY-D4	—

- (1) Replace x with 2 (2 m [6.6 ft]), 5 (5 m [16.4 ft]), or 10 (10 m [32.8 ft]) for standard cable lengths.
- (2) Replace y with 1 (1 m [3.3 ft]), 2 (2 m [6.6 ft]), 3 (3 m [9.8 ft]), 5 (5 m [16.4 ft]), or 10 (10 m [32.8 ft]) for standard cable lengths.
- (3) Replace z with 4 or 8 for number of ports.

Accessories

Table 65 - Interlock Switch Accessories

Description	Cat. No.
MC1 spare actuator	440N-A17233
MC2 spare actuator	440N-A32114

Approximate Dimensions

Dimensions are not intended to be used for installation purposes.

Figure 35 - MC1 [mm (in.)]

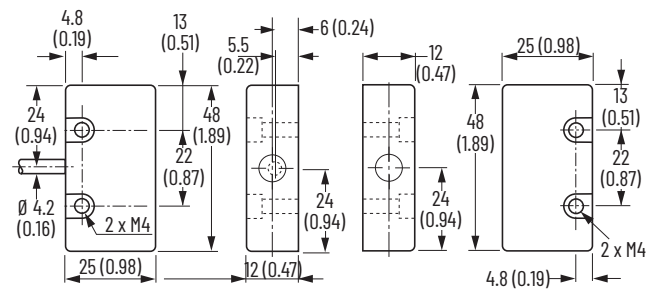
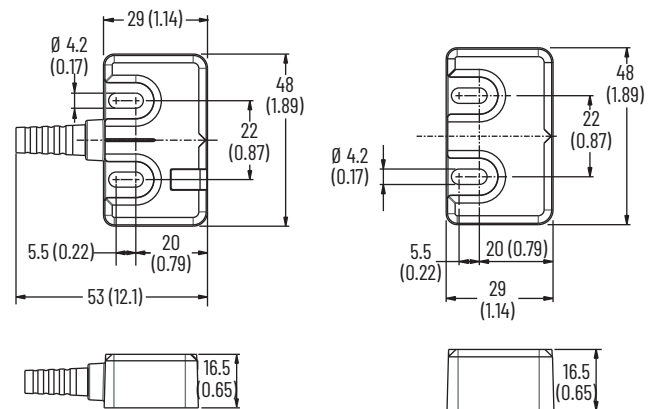
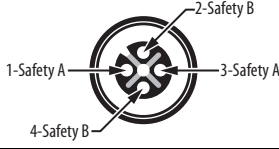
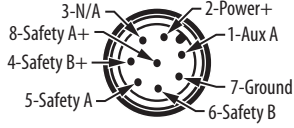

Figure 36 - MC2 [mm (in.)]



Typical Wiring Diagrams

Table 66 - Interlock Switch Wiring

Description		MC1 – 2 N.C.	MC2 – 2 N.C. and 1 N.O.
4-pin Micro (M12)			—
8-pin Micro (M12)		—	
Cordset 889D-F4AC-x or Cable Version ⁽¹⁾	Brown	Safety A	—
	Blue		
	White	Safety B	—
	Black		
8-pin Cordset 889D-F8AB-x or Cable Version ⁽¹⁾	Gray	—	Safety A
	Red		Safety A
	Pink		Safety B
	Yellow		Safety B
	White		Aux
	Brown		24V DC +
	Blue		Gnd
	Green		—

(1) Replace x with 2 (2 m [6.6 ft]), 5 (5 m [16.4 ft]) or 10 (10 m [32.8 ft]) for standard cable lengths.

Ferrogard 1, 2, 20, and 21 Non-contact Interlock Switches

The Ferrogard™ 1, 2, 20, and 21 non-contact interlock switches have the following features:

- Non-contact actuation
- High tolerance to misalignment
- High switching current (up to 2 A AC, 1 A DC)
- Plastic rectangular housing (IP67)
- Cable or quick-disconnect (QD) connections



Specifications

Table 67 - Interlock Switch Specifications

Attribute	Value
Safety Ratings	
Standards	ISO 14119, IEC 60947-5-3, ISO 13849-1, IEC 62061
Safety classification	Cat. 1 Device per ISO13849-1. Dual channel interlocks suitable for Cat. 3 or 4 systems
Functional safety data	B10d: > 2 x 10 ⁶ operations Dual channel interlock can be suitable for Performance Level PL _e or PL _d (according to ISO 13849-1) and for use in SIL 2 or SIL 3 systems (according to IEC 62061) depending on application characteristics
Certifications	CE Marked for all applicable directives and UKCA Marked for all applicable regulations rok.auto/certifications
Outputs (Guard Door Closed, Actuator in Place)	
Safety outputs	<ul style="list-style-type: none"> • FRS1: 1 N.C. • FRS2: 1 N.C. • FRS20: 2 N.C. • FRS21: 2 N.C.
Auxiliary outputs	<ul style="list-style-type: none"> • FRS1: None • FRS2: 1 N.O. • FRS20: None • FRS21: 1 N.O.
Operating Characteristics	
Operating distance, make	<ul style="list-style-type: none"> • Safety: 12 mm (0.47 in.) • Auxiliary: 15 mm (0.59 in.)
Operating distance, break	<ul style="list-style-type: none"> • Safety: 23 mm (0.91 in.) • Auxiliary: 26 mm (1.02 in.)
Fuses, external	<ul style="list-style-type: none"> • FRS1, 2 and 21: 1.6 A (Bussmann BK/60 A-1.6 A) max • FRS20: 0.4 A (Bussmann BK/60 A-400 mA) max
Environmental	
Enclosure type rating	IP67 (NEMA 6P)
Operating temperature	-10...+55 °C (14...131 °F)
Relative humidity	5...95%
Shock	50 g
Vibration	7 g; 50...200 Hz
Radio frequency	IEC 61000-4-3, IEC 61000-4-6
Physical Characteristics	
Material	<ul style="list-style-type: none"> • Housing: Molded ABS plastic • Actuator: Molded ABS plastic
Weight	FRS 1 <ul style="list-style-type: none"> • Sensor: 35 g (0.08 lb) • Actuator: 85 g (0.19 lb) FRS 2 <ul style="list-style-type: none"> • Sensor: 40 g (0.09 lb) • Actuator: 85 g (0.19 lb) FRS 20 <ul style="list-style-type: none"> • Sensor: 43 g (0.09 lb) • Actuator: 85 g (0.19 lb) FRS 21 <ul style="list-style-type: none"> • Sensor: 43 g (0.09 lb) • Actuator: 85 g (0.19 lb)
Color	Red

Product Selection

Table 68 - Interlock Switch Product Selection

Switching Capability	Safety Contacts ⁽¹⁾	Auxiliary Contacts ⁽¹⁾	Connection	Type	Cat. No.
250V AC, 2 A max	1 N.C.	—	2 m (6.6 ft) cable	FRS 1	440N-G02001
			4 m (13.1 ft) cable		440N-G02004
			6 m (19.7 ft) cable		440N-G02022
			8 m (26.2 ft) cable		440N-G02041
			10 m (32.8 ft) cable		440N-G02015
		1 N.O.	2 m (6.6 ft) cable	FRS 2	440N-G02002
			4 m (13.1 ft) cable		440N-G02014
			6 m (19.7 ft) cable		440N-G02038
			8 m (26.2 ft) cable		440N-G02033
			10 m (32.8 ft) cable		440N-G02019
	2 N.C.	—	15 m (49.2 ft) cable	FRS 20	440N-G02043
			20 m (65.6 ft) cable		440N-G02040
	2 N.C.	1 N.O.	4-pin Micro QD	FRS 21	440N-G02093
			2 m (6.6 ft) cable		440N-G02097
			4 m (13.1 ft) cable		440N-G02055
			6 m (19.7 ft) cable		440N-G02061
			10 m (32.8 ft) cable		440N-G02060
			6-pin AC Micro QD ⁽²⁾		440N-G02059
24V DC, 1 A	1 N.C.	1 N.O.	2 m (6.6 ft) cable	FRS 2	440N-G02092
			4-pin Micro QD		440N-G02094
	2 N.C.	—	4 m (13.1 ft) cable	FRS 20	440N-G02085
			4-pin Micro QD		440N-G02090
		1 N.O.	2 m (6.6 ft) cable	FRS 21	440N-G02058
			4 m (13.1 ft) cable		440N-G02077
			6 m (19.7 ft) cable		440N-G02083
			6-pin AC Micro QD		440N-G02099

(1) Contacts are described with the guard door closed, that is, the actuator in place. Switch is shipped complete with actuator.

(2) For connector ratings, see [Table 70](#).

Table 69 - Connection Systems

Description	Cat. No.	
	Connection to Distribution Box 4-pin Micro (M12) 1 N.C. and 1 N.O.	6-pin AC Micro (M12) 2 N.C. and 1 N.O.
Cordset	889D-F4AC-x ⁽¹⁾	889R-F6ECA-x ⁽¹⁾
Patchcord	889D-F4ACDM-y ⁽²⁾	889R-F6ECRM-y ⁽²⁾
Distribution box	898D-4zKT-DM4 ⁽³⁾	898R-P68MT-A5
Shorting plug	898D-41KU-DM	898R-61MU-RM
T-port	898D-43KY-D4	—

(1) Replace x with 2 (2 m [6.6 ft]), 5 (5 m [16.4 ft]), or 10 (10 m [32.8 ft]) for standard cable lengths.

(2) Replace y with 1 (1 m [3.3 ft]), 2 (2 m [6.6 ft]), 3 (3 m [9.8 ft]), 5 (5 m [16.4 ft]), or 10 (10 m [32.8 ft]) for standard cable lengths.

(3) Replace z with 4 or 8 for number of ports.

Table 70 - Connector Ratings

Description	Max Ratings		Applicable Standards
	AC	DC	
4-pin Micro (M12)	250V, 4 A	250V, 4 A	IEC 61076-2-101:2003
5-pin Micro (M12)	60V, 4 A	60V, 4 A	IEC 61076-2-101:2003
6-pin Micro (M12)	30V, 2 A	30V, 2 A	IEC 61076-2-101:2003
8-pin Micro (M12)	30V, 2 A	30V, 2 A	IEC 61076-2-101:2003
12-pin M23	63V, 6 A	63V, 6 A	IEC 61984:2001

Accessories

Table 71 - Interlock Switch Accessories

Description	Cat. No.
Replacement actuator	440N-A02005

Approximate Dimensions

Dimensions are not intended to be used for installation purposes.

Figure 37 - Interlock Switch Dimensions [mm (in.)]

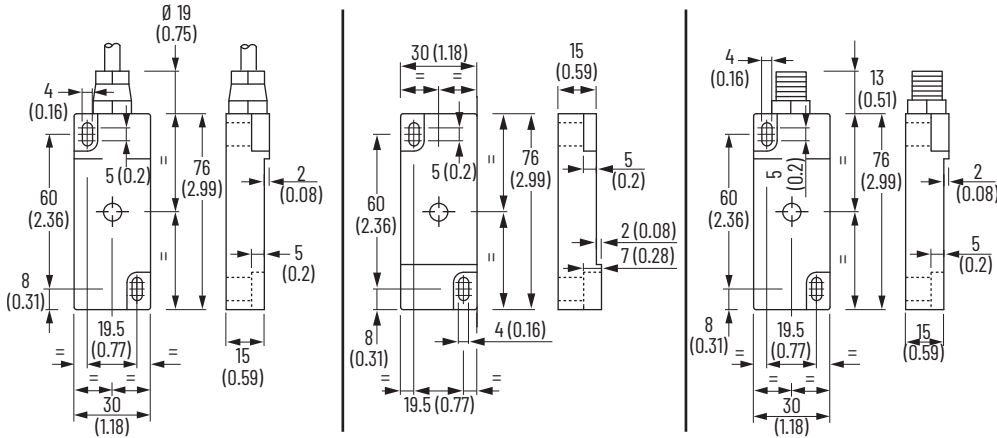

Typical Wiring Diagrams

Table 72 - Interlock Switch Wiring

Description		FRS1 1 N.C.	FRS2 DC Micro 1 N.C. + 1 N.O.	FRS20 DC Micro 2 N.C.	FRS21 AC Micro 2 N.C. + 1 N.O.
4-pin Micro (M12)		—			—
6-pin AC Micro (M12)		—	—	—	
Cordset 889D-F4AC-x or Cable Versions ⁽¹⁾	Brown	—	Safety A	Safety A	—
	Blue	—	—	—	—
	Black	—	—	—	—
	White	—	—	—	—
Cordset 889R-F6ECA-x ⁽¹⁾	Red/White	—	—	—	Safety A
	Red/Black	—	—	—	Safety B
	Red	—	—	—	Aux A
	Red/Blue	—	—	—	—
	Green	—	—	—	—
Cable Versions	Safety A	Brown	Blue	Brown	Black
		Blue	White	Blue	White
	Safety B	—	Yellow	Black	Red
		—	Green	White	Blue
Aux A	—	—	—	Yellow	
					Green

(1) Replace x with 2 (2 m [6.6 ft]), 5 (5 m [16.4 ft]), or 10 (10 m [32.8 ft]) for standard cable lengths.

Ferrogard 3, 4, and 5 Non-contact Interlock Switches

The Ferrogard 3, 4, and 5 non-contact interlock switches have the following features:

- Non-contact actuation
- High tolerance to misalignment
- High switching current (up to 2 A)
- Various contact arrangements
- Terminal connections

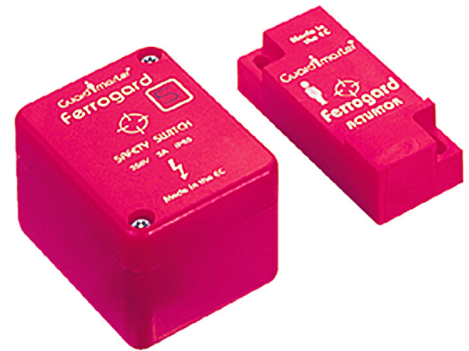

Specifications

Table 73 - Interlock Switch Specifications

Attribute	Value
Safety Ratings	
Standards	ISO 14119, IEC 60947-5-3, ISO 13849-1, IEC 62061
Safety classification	Cat. 1 Device per ISO13849-1. Dual-channel interlocks suitable for Cat. 3 or 4 systems
Functional safety data	B10d: > 2 x 10 ⁶ operations Dual channel interlock can be suitable for Performance Level PLe or PLd (according to ISO 13849-1) and for use in SIL 2 or SIL 3 systems (according to IEC 62061) depending on application characteristics
Certifications	CE Marked for all applicable directives and UKCA Marked for all applicable regulations rok.auto/certifications
Outputs (Guard Door Closed, Actuator in Place)	
Safety outputs	<ul style="list-style-type: none"> • FRS3: 1 N.C. • FRS4: 1 N.C. • FRS5: 1 N.C.
Auxiliary outputs	<ul style="list-style-type: none"> • FRS3: 1 N.C. • FRS4: 1 N.O. • FRS5: None
Operating Characteristics	
Operating distance, make [mm (in.)]	Safety/Auxiliary: <ul style="list-style-type: none"> • FRS 3: 12 (0.47) • FRS 4: 12 (0.47) • FRS 5: 12 (0.47)
Operating distance, break [mm (in.)]	Safety/Auxiliary: <ul style="list-style-type: none"> • FRS 3: 24 (0.94) • FRS 4: 10 (0.39) • FRS 5: 12 (0.47)
Auxiliary contact switching capability	300V DC, 250V AC 0.5 A including inrush, min
Safety contact external fusing	≤1.6 A quick blow
Environmental	
Enclosure type rating	IP65 (NEMA 13)
Operating temperature	-10...+65 °C (14...149 °F)
Relative humidity	5...95%
Shock	IEC 68-2-27, 30 g, 11 ms
Vibration	IEC 68-2-6, 10...200 Hz
Radio frequency	IEC 61000-4-3, IEC 61000-4-6
Physical Characteristics	
Material	<ul style="list-style-type: none"> • Housing: Molded ABS plastic • Actuator: Molded ABS plastic
Color	Red

Product Selection

Table 74 - Interlock Switch Product Selection

Safety Contact Switching Capability	Connection Type	Housing Material	Safety Contacts ⁽¹⁾	Auxiliary Contacts ⁽¹⁾	Type	Cat. No.
250V AC 2 A max	Terminals	Red molded ABS plastic	1 N.C.	1 N.C.	FRS 3	440N-G02003
				1 N.O.	FRS 4	440N-G02008
				—	FRS 5	440N-G02009

(1) Contacts are described with the guard door closed, that is, the actuator in place.

Accessories

Table 75 - Ferrogard Non-contact Interlock Switch Accessories

Description	Cat. No.
Replacement actuator	440N-A02005

Approximate Dimensions

Dimensions are not intended to be used for installation purposes.

Figure 38 - Interlock Switch Dimensions [mm (in.)]

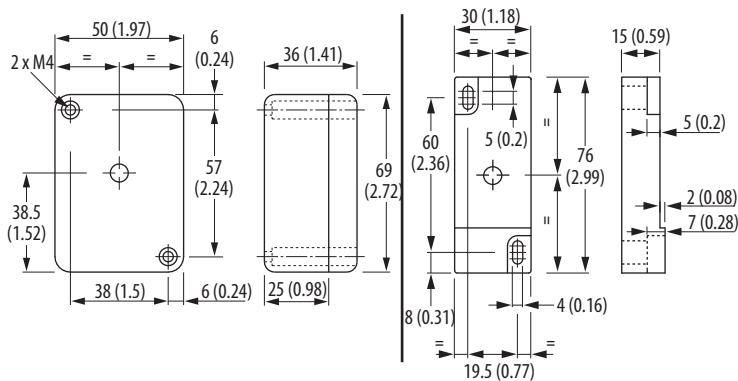

Typical Wiring Diagrams

Figure 39 - Interlock Switch Wiring

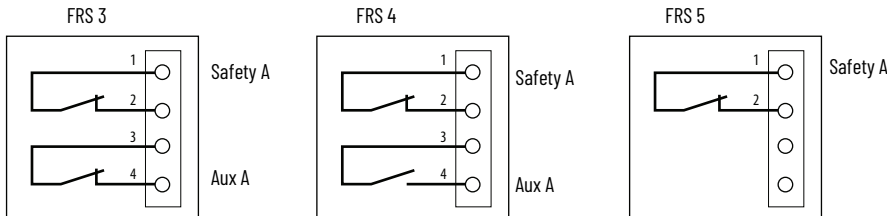

Ferrogard 6, 9, 10, 13, and 14 Non-contact Interlock Switches

The Ferrogard 6, 9, 10, 13, and 14 non-contact interlock switches have the following features:

- Non-contact actuation
- High tolerance to misalignment
- High switching current (up to 3 A)
- Two sensing faces
- IP67 (NEMA 6P) rating
- Slim housings

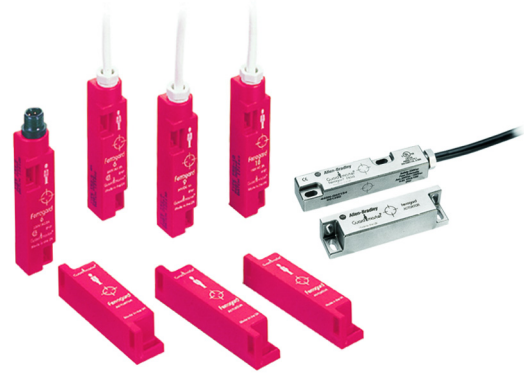

Specifications

Table 76 - Interlock Switch Specifications

Attribute	Value
Safety Ratings	
Standards	ISO 14119, IEC 60947-5-3, ISO 13849-1, IEC 62061
Safety classification	Cat. 1 Device per ISO13849-1. Dual channel interlocks suitable for Cat. 3 or 4 systems
Functional safety data For up-to-date information, visit https://www.rockwellautomation.com/en-us/products/hardware/allen-bradley/safety-products.html	B10d: > 2 x 10 ⁶ operations Dual channel interlock can be suitable for Performance Level PLe or PLd (according to ISO 13849-1) and for use in SIL 2 or SIL 3 systems (according to IEC 62061) depending on application characteristics
Certifications	<ul style="list-style-type: none"> • FRS6, FRS9, FRS10: CE Marked for all applicable directives and UKCA Marked for all applicable regulations rok.auto/certifications • FRS13, FRS14: CE Marked for all applicable directives, UKCA Marked for all applicable regulations, and cULus Listed rok.auto/certifications
Outputs (Guard Door Closed, Actuator in Place)	
Safety outputs	1 N.C. 1 N.C.
Auxiliary outputs	— 1 N.C.
Operating Characteristics	
Operating distance, make	12 mm (0.47 in.)
Operating distance, break	23 mm (0.91 in.)
Environmental	
Enclosure type rating	IP67 (NEMA 6P)
Operating temperature	-10...+65 °C (14...149 °F)
Relative humidity	5...95%
Shock	IEC 68-2-27, 30 g, 11 ms
Vibration	IEC 68-2-6, 10...55 Hz
Radio frequency	IEC 61000-4-3, IEC 61000-4-6
Physical Characteristics	
Material	<ul style="list-style-type: none"> • Housing: Molded ABS plastic • Actuator: Molded ABS plastic
Weight	<ul style="list-style-type: none"> • Sensor: 28 g (0.06 lb) • Actuator: 70 g (0.15 lb)
Color	Red

Product Selection

Table 77 - Interlock Switch Product Selection

Safety Contact Switching Capability	Safety Contacts ⁽¹⁾	Auxiliary Contacts ⁽¹⁾	Housing Material	Type	Connection	Cat. No.
250V AC, 2 A	1 N.C.	-	Red molded ABS plastic	FRS 6	2 m (6.6 ft) cable	440N-G02023
					4 m (13.1 ft) cable	440N-G02028
					6 m (19.7 ft) cable	440N-G02032
					10 m (32.8 ft) cable	440N-G02013
					4-pin Micro QD	440N-G02095
24V DC, 1 A				FRS 9	2 m (6.6 ft) cable	440N-G02044
					4 m (13.1 ft) cable	440N-G02075
					6 m (19.7 ft) cable	440N-G02082
					10 m (32.8 ft) cable	440N-G02089
110V AC, 3 A				FRS 10	2 m (6.6 ft) cable	440N-G02045
	4 m (13.1 ft) cable	440N-G02088				
250V AC, 2 A	1 N.C.	Stainless steel	FRS 13	2 m (6.6 ft) cable	440N-G02154	
				4 m (13.1 ft) cable	440N-G02155	
FRS 14			8-pin Micro QD	440N-G02160		
			2 m (6.6 ft) cable	440N-G02156		
24V DC, 1 A			FRS 14	4 m (13.1 ft) cable	440N-G02157	
				8-pin Micro QD	440N-G02161	

(1) Contacts are described with the guard door closed, that is, the actuator in place.

Table 78 - Connection Systems

Description	Cat. No.	
	4-pin Micro (M12)	8-pin Micro (M12)
Cordset	889D-F4AC-x ⁽¹⁾	889D-F8AB-x ⁽¹⁾
Patchcord	889D-F4ACDM-y ⁽²⁾	889D-F8ABDM-y ⁽²⁾

(1) Replace x with 2 (2 m [6.6 ft]), 5 (5 m [16.4 ft]), or 10 (10 m [32.8 ft]) for standard cable lengths.

(2) Replace y with 1 (1 m [3.3 ft]), 2 (2 m [6.6 ft]), 3 (3 m [9.8 ft]), 5 (5 m [16.4 ft]), or 10 (10 m [32.8 ft]) for standard cable lengths.

Accessories

Table 79 - Interlock Switch Accessories

Description	Cat. No.
FRS 6, 9, 10 plastic replacement actuator	440N-A02025
FRS 13, 14 stainless-steel replacement actuator	440N-A02165

Approximate Dimensions

Dimensions are not intended to be used for installation purposes.

Figure 40 - FRS 6, 9, and 10 [mm (in.)]

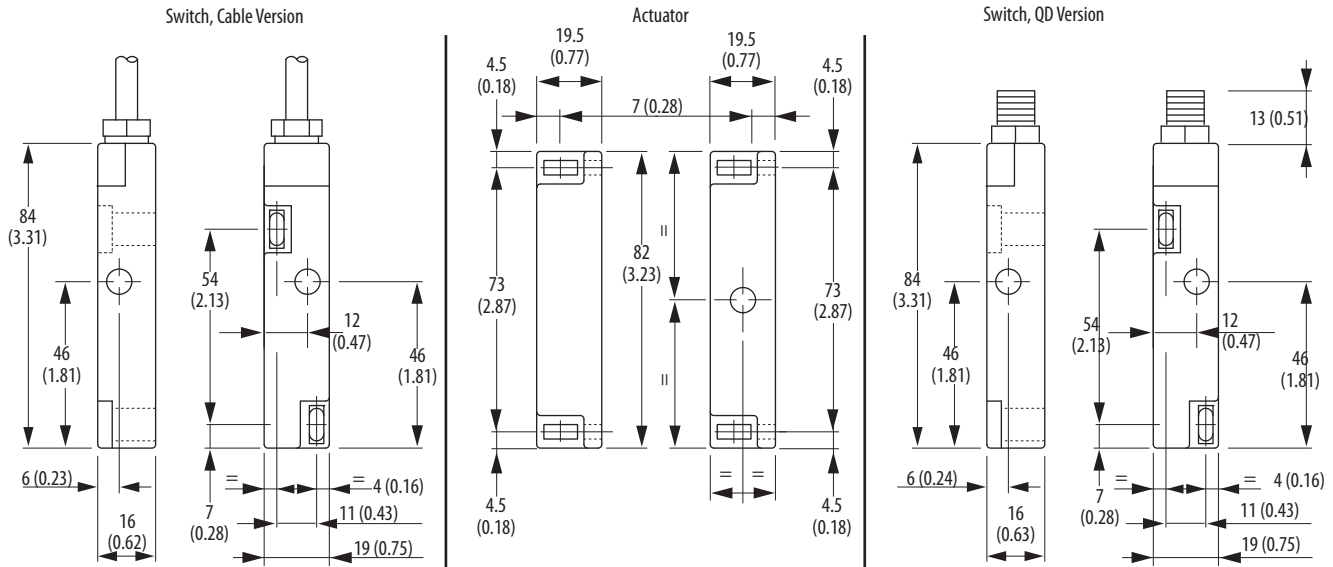
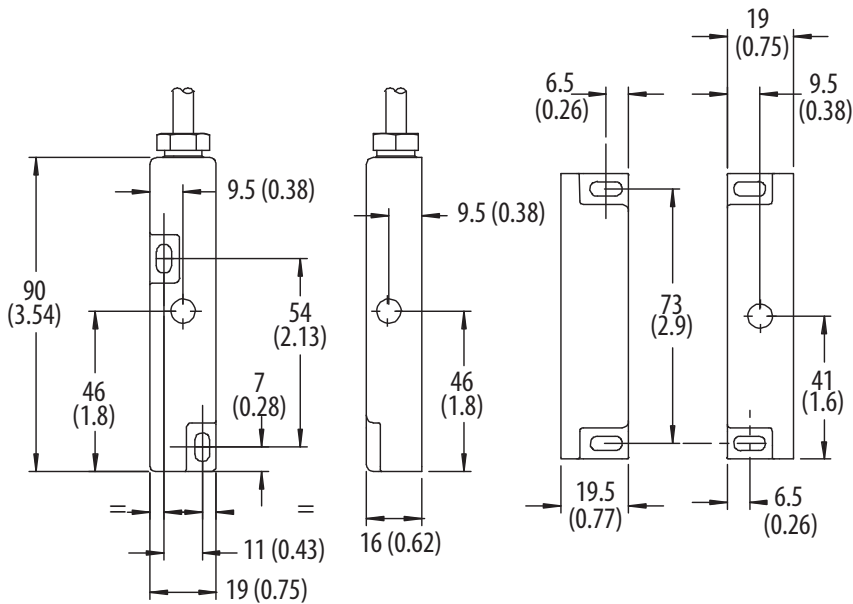
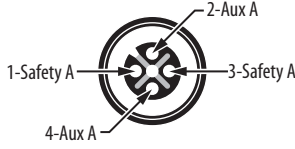
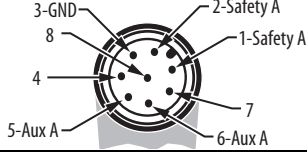

Figure 41 - FRS 13 and 14 [mm (in.)]



Typical Wiring Diagrams

Table 80 - Interlock Switch Wiring

Description		FRS 6, 9 and 10 1 N.C.	FRS 13 and 14 1 N.C. and 1 N.C.
4-pin Micro (M12)			—
8-pin Micro (M12)		—	
Cordset 889D-F4AC-x ⁽¹⁾	Brown	Safety A	Safety A
	Blue	Safety A	Safety A
	White	—	Aux A
	Black	—	Aux A
Cordset 889D-F8AB-x ⁽¹⁾	White	—	Safety A
	Brown	—	Aux A
	Gray	—	Aux A
	Pink	—	Aux A
Cable version	Safety A	Brown	Brown
		Blue	Blue
	Aux A	—	Black
		—	Gray

(1) Replace x with 2 (2 m [6.6 ft]), 5 (5 m [16.4 ft]), or 10 (10 m [32.8 ft]) for standard cable lengths.



WARNING: All safety contacts fitted with an internal non-resettable fuse and must be fused externally as detailed.

Table 81 - External Fuse Safety Contacts

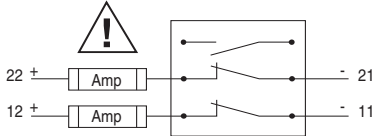
	
FRS 1, 2, 3, 4, 5, 6, 13, 21 AC	AC 1.6 A ⁽¹⁾ ≤ (F) IEC 60127-2
FRS 9, 14, 2 DC, 20 DC, 21 DC	DC 0.4 A ⁽²⁾ ≤ (F) IEC 60127-2
FRS 10	AC 2.5 A ⁽³⁾ ≤ (F) IEC 60127-2

- (1) Recommended: Bussman BK/GDA-1.6 A
- (2) Recommended: Bussman BK/GDA-400 mA
- (3) Recommended: Bussman BK/GDA-2.5 A

Ferrogard GD2 Non-contact Interlock Switches

The Ferrogard GD2 non-contact interlock switches have the following features:

- Non-contact actuation
- High tolerance to misalignment
- High switching current (up to 2 A AC, 1 A DC)
- Wide temperature range (-25...+125 °C [-13...+257 °F])
- Stainless-steel housing
- Various contact arrangements



Specifications

Table 82 - Interlock Switch Specifications

Attribute	Value		
Safety Ratings			
Standards	ISO 14119, IEC 60947-5-3, ISO 13849-1, IEC 62061		
Safety classification	Dual channel interlocks suitable for Cat. 3 or 4 systems		
Functional safety data	B10d: > 2 x 10 ⁶ operations Dual channel interlock can be suitable for Performance Level PLe or PLd (according to ISO 13849-1) and for use in SIL 2 or SIL 3 systems (according to IEC 62061) depending on application characteristics		
Certifications	CE Marked for all applicable directives, UKCA Marked for all applicable regulations, and cULus Listed rok.auto/certifications		
Outputs (Guard Door Closed, Actuator in Place)			
Safety outputs	1 N.C.	2 N.C.	2 N.C.
Auxiliary outputs	1 N.O.	—	1 N.O.
Operating Characteristics			
Operating distance, make [mm (in.)]	<ul style="list-style-type: none"> • Safety: 12 (0.47) • Auxiliary: 15 (0.59) 		
Operating distance, break [mm (in.)]	<ul style="list-style-type: none"> • Safety: 23 (0.91) • Auxiliary: 26 (1.02) 		
Environmental			
Enclosure type rating	IP68 (NEMA 6P)		
Operating temperature	-25...+125 °C (-13...+257 °F)		
Relative humidity	5...95%		
Shock	IEC 68-2-27, 30 g, 11 ms		
Vibration	IEC 68-2-6, 10...200 Hz		
Radio frequency	IEC 61000-4-3, IEC 61000-4-6		
Physical Characteristics			
Material	<ul style="list-style-type: none"> • Housing: Stainless steel; BS3146 ANC4B (316L) • Actuator: Stainless steel; BS3146 ANC4B (316L) 		
Weight	<ul style="list-style-type: none"> • Sensor: 156 g (0.34 lb) • Actuator: 168 g (0.37 lb) 		

Product Selection

Table 83 - Interlock Switch Product Selection

Safety Contact Switching Capability	Safety Contacts ⁽¹⁾	Auxiliary Contacts ⁽¹⁾	Connection	Type	Cat. No.
250V AC, 2 A max	2 N.C.	—	3 m (9.8 ft) cable	FRS 20 GD2	440N-G02113
	1 N.C.	1 N.O.	3 m (9.8 ft) cable	FRS 2 GD2	440N-G02112
	2 N.C.		3 m (9.8 ft) cable	FRS 21 GD2	440N-G02117
24V DC, 1 A max	1 N.C.	1 N.O.	3 m (9.8 ft) cable	FRS 2 GD2	440N-G02118
			10 m (32.8 ft) cable	FRS 2 GD2	440N-G02147
	2 N.C.	—	3 m (9.8 ft) cable	FRS 20 GD2	440N-G02119
	2 N.C.	1 N.O.	3 m (9.8 ft) cable	FRS 21 GD2	440N-G02123
			6 m (19.7 ft) cable	FRS 21 GD2	440N-G02143
			10 m (32.8 ft) cable	FRS 21 GD2	440N-G02137
			8-pin Micro (M12)	FRS 21 GD2	440N-G02149

(1) Contacts are described with the guard door closed, that is, the actuator in place. Switch is shipped with complete actuator.

Table 84 - Connection Systems

Description	Cat. No.
	8-pin Micro (M12)
Cordset	889D-F8AB-x ⁽¹⁾
Patchcord	889D-F8ABDM-y ⁽²⁾

- (1) Replace x with 2 (2 m [6.6 ft]), 5 (5 m [16.4 ft]), or 10 (10 m [32.8 ft]) for standard cable lengths.
- (2) Replace y with 1 (1 m [3.3 ft]), 2 (2 m [6.6 ft]), 3 (3 m [9.8 ft]), 5 (5 m [16.4 ft]), or 10 (10 m [32.8 ft]) for standard cable lengths.

Accessories

Table 85 - Interlock Switch Accessories

Description	Cat. No.
Actuator	440N-A02128

Approximate Dimensions

Dimensions are not intended to be used for installation purposes.

Figure 42 - Switch [mm (in.)]

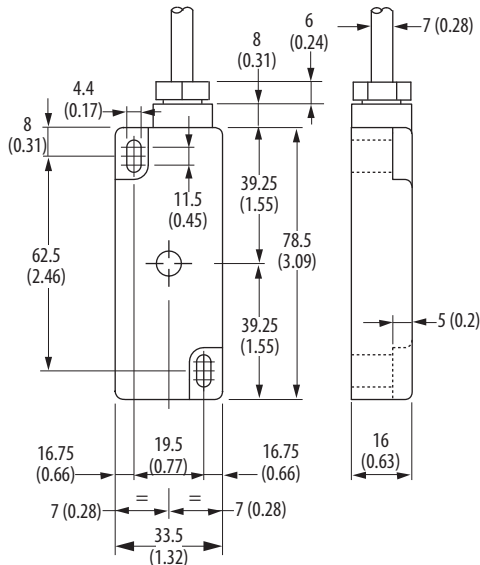
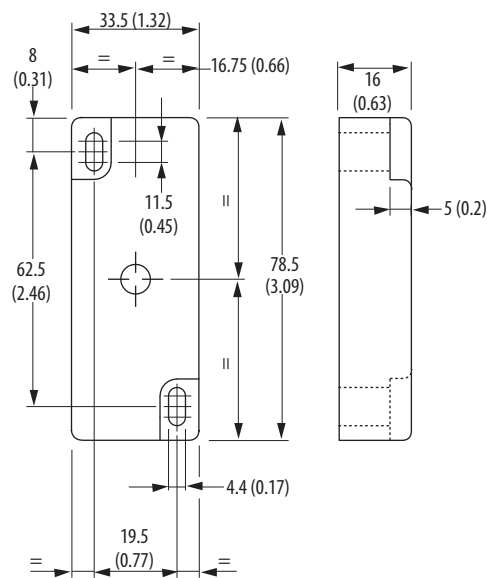

Figure 43 - Actuator [mm (in.)]



Typical Wiring Diagrams

Table 86 - Interlock Switch Wiring

Description		FRS21 2 N.C. and 1 N.O.	FRS2 1 N.C. and 1 N.O.	FRS20 2 N.C.
Cable versions	Safety A	Black	Blue	Brown
		White	Red	Blue
	Safety B	Red	-	Black
		Blue		White
	Aux A	Yellow	Yellow	
Green		Green		
Shield Gnd	-	Green/ Yellow	Green/ Yellow	
8-pin Micro (M12)		-	-	
Cordset 889D-F8AB-x ⁽¹⁾	Brown White	Safety A	-	-
	Gray Pink	Safety B	-	-
	Yellow Red	Safety B	-	-
	Green Blue	-	-	-

(1) Replace x with 2 (2 m [6.6 ft]), 5 (5 m [16.4 ft]), or 10 (10 m [32.8 ft]) for standard cable lengths.



WARNING: All safety contacts fitted with an internal non-resettable fuse and must be fused externally as detailed.

Table 87 - External Fuse Safety Contacts

FRS 2 GD2 FRS20 GD2 FRS21 GD2	AC 1.6 A ⁽¹⁾ ≤ (F) IEC 60127-2
FRS 2 GD2 FRS 20 GD2 FRS21 GD2	DC 0.4 A ⁽²⁾ ≤ (F) IEC 60127-2

(1) Recommended: Bussman BK/GDA-1.6 A

(2) Recommended: Bussman BK/GDA-400 mA

Ferrogard GS1 and GS2 Non-contact Interlock Switches

The Ferrogard GS1 and GS2 non-contact interlock switches have the following features:

- Non-contact actuation
- High tolerance to misalignment
- High switching current (2 A AC)
- Metal housings (IP68)
- Ex Range version available

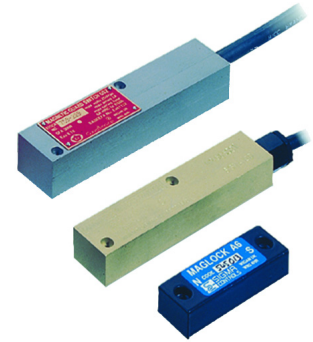

Specifications

Table 88 - Interlock Switch Specifications

Attribute	Value
Safety Ratings	
Standards	ISO 14119, IEC 60947-5-3, ISO 13849-1, IEC 62061
Safety classification	Cat. 1 Device per ISO13849-1. Dual channel interlocks suitable for Cat. 3 or 4 systems
Functional safety data	B10d: > 2 x 10 ⁶ operations Dual channel interlock can be suitable for Performance Level PL _e or PL _d (according to ISO 13849-1) and for use in SIL 2 or SIL 3 systems (according to IEC 62061) depending on application characteristics
Certifications	<ul style="list-style-type: none"> • GS1 and GS2: CE Marked for all applicable directives and UKCA Marked for all applicable regulations rok.auto/certifications • GS2 Ex: EExd IIC T6 Baseefa
Outputs (Guard Door Closed, Actuator in Place)	
Safety outputs	1 N.C.
Auxiliary outputs	—
Operating Characteristics	
Operating distance, make	<ul style="list-style-type: none"> • GS1: 12 mm (0.47 in.) • GS2: 15 mm (0.59 in.)
Operating distance, break	<ul style="list-style-type: none"> • GS1: 23 mm (0.91 in.) • GS2: 26 mm (1.02 in.)
Environmental	
Enclosure type rating	IP68 (NEMA 6P)
Operating temperature	<ul style="list-style-type: none"> • GS1: -25...+125 °C (-13...+257 °F) • GS2: -40...+60 °C (-40...+146 °F)
Relative humidity	5...95%
Shock	IEC 68-2-27, 30 g, 11 ms
Vibration	IEC 68-2-6, 10...55 Hz
Radio frequency	IEC 61000-4-3, IEC 61000-4-6
Physical Characteristics	
Material	GS1 <ul style="list-style-type: none"> • Housing: Stainless steel; BS3146 ANC4B (316L) • Actuator: Epoxy-painted stainless steel GS2 <ul style="list-style-type: none"> • Housing: Brass • Actuator: Brass
Weight	<ul style="list-style-type: none"> • GS1: 381 g (0.84 lb) • GS2: 388 g (0.86 lb) • Actuator: 116 g (0.24 lb)

Product Selection

Table 89 - Interlock Switch Product Selection

Safety Contact Switching Capability	Connection Type	Housing Material	Safety Contacts ⁽¹⁾	Auxiliary Contacts ⁽¹⁾	Type	Cat. No.
250V AC, 2 A	2 m (6.6 ft) cable	Brass	1 N.C.	None	GS 1	440N-G02048
		Stainless steel				440N-G02049
	3 m (9.8 ft) cable	Brass			GS2-Ex (brass)	440N-H02046
		Stainless steel			GS2-Ex (stainless steel)	440N-H02047

(1) Contacts are described with the guard door closed, that is, the actuator in place. Switch is shipped with complete actuator.

Accessories

Table 90 - Interlock Switch Accessories

Description	Used with	Cat. No.
Actuator, Alnico	Brass switch	440N-A02056
Actuator, epoxy-painted	Stainless-steel switch	440N-A02057

Approximate Dimensions

Dimensions are not intended to be used for installation purposes.

Figure 44 - Interlock Switch Dimensions [mm (in.)]

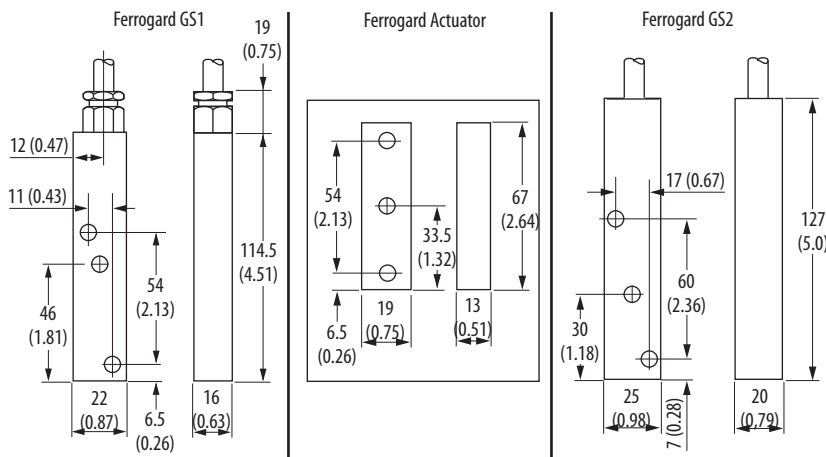

Typical Wiring Diagram

Figure 45 - Interlock Switch Wiring

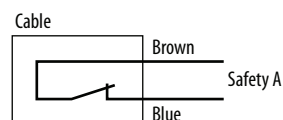

Table 91 - External Fuse Safety Contacts

GS1	AC 1.6 A ⁽¹⁾ ≤ (F) IEC 60127-2
GS2	

(1) Recommended: Bussman BK/GDA-1.6 A



WARNING: All safety contacts fitted with an internal non-resettable fuse and must be fused externally as detailed.

Sipha Sensors

Sipha™ sensors have the following features:

- Non-contact actuation
- Magnetically coded sensing
- Four housing styles
- Must be operated with its own safety control unit

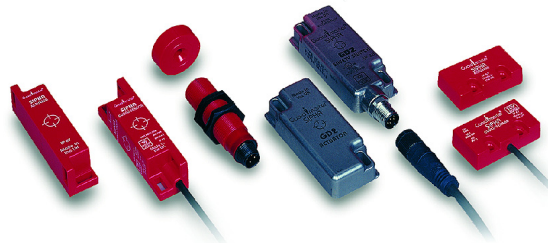





Specifications

Table 92 - Sensor Specifications

Attribute	Value
Safety Ratings	
Standards	ISO 14119, ISO 13849-1, IEC 60947-5-3, IEC 62061, IEC 61508
Safety classification	Rating dependent on control unit and application
Functional safety data	B10d: > 2 x 10 ⁶ operations Dual channel interlock can be suitable for Performance Level PLe or PLd (according to ISO 13849-1) and for use in SIL 2 or SIL 3 systems (according to IEC 62061) depending on application characteristics
Certifications	CE Marked for all applicable directives, UKCA Marked for all applicable regulations, cULus Listed, and TÜV Certified rok.auto/certifications
Outputs (Guard Door Closed, Actuator in Place)	
Auxiliary output switching	300V DC, 250V AC, 0.5 A including inrush. 15V A/10 W suitable for AC/DC circuits.
Operating Characteristics	
Sensing distance, make	<ul style="list-style-type: none"> • S1 and S3: 5 mm (0.20 in.) • S2: 9 mm (0.35 in.) • S4: 10 mm (0.39 in.)
Sensing distance, break	<ul style="list-style-type: none"> • S1: 11 mm (0.43 in.) • S2 and S3: 12 mm (0.47 in.) • S4: 13 mm (0.51 in.)
Environmental	
Enclosure type rating	IP67 (NEMA 6P)
Operating temperature	<ul style="list-style-type: none"> • S1, S2, and S3: -10...+55 °C (14...131 °F) • S4 (GD2): -25...+125 °C (-13...+257 °F)
Shock	30 g, 11 ms half-sine
Vibration	1 mm (0.04 in.), 10...55 Hz
Physical Characteristics	
Cable size	0.54 mm ² (20 AWG) 4-wire PVC Jacket OD: 4 mm (0.16 in.)
Material	<ul style="list-style-type: none"> • S1 and S2: Molded ABS • S30 (Actuator): Polyester • S31 (Sensor): Nylon (Trogamid) • S4 (GD2): Stainless steel
Mounting	Any position
Weight	S1 <ul style="list-style-type: none"> • Sensor: 18 g (0.04 lb) • Actuator: 15 g (0.03 lb) S2 <ul style="list-style-type: none"> • Sensor: 20 g (0.04 lb) • Actuator: 30 g (0.07 lb) S3 <ul style="list-style-type: none"> • Sensor: 18 g (0.04 lb) • Actuator: 6 g (0.01 lb) S4 <ul style="list-style-type: none"> • Sensor: 150 g (0.33 lb) • Actuator: 170 g (0.37 lb)

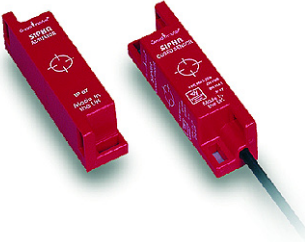
Product Selection

Table 93 - Sensor Product Selection

Housing Style	Housing Material	Safety Contacts ⁽¹⁾	Auxiliary Contacts ⁽¹⁾	Type	Connection	Cat. No.	
	ABS plastic	1 N.C. and 1 N.O.	None	S11	3 m (9.8 ft) cable	440N-S32014	
					10 m (32.8 ft) cable	440N-S32016	
			1 N.C.	S12	3 m (9.8 ft) cable	440N-S32022	
					10 m (32.8 ft) cable	440N-S32032	
			1 N.O.	S13	3 m (9.8 ft) cable	440N-S32037	
					10 m (32.8 ft) cable	440N-S32036	
	ABS plastic	1 N.C. and 1 N.O.	None	S21	3 m (9.8 ft) cable	440N-S32015	
					10 m (32.8 ft) cable	440N-S32017	
			1 N.C.	S22	3 m (9.8 ft) cable	440N-S32023	
					10 m (32.8 ft) cable	440N-S32033	
	Actuator— Polyester Sensor— Nylon (Trogamid)	1 N.C. and 1 N.O.		S23	3 m (9.8 ft) cable	440N-S32038	
						10 m (32.8 ft) cable	440N-S32039
	Stainless steel	1 N.C. and 1 N.O.	None	S31	3 m (9.8 ft) cable	440N-S32101	
					4-pin Micro (M12)	440N-S32024	
	Stainless steel	1 N.C. and 1 N.O.	1 N.C.	S42	8-pin Micro (M12)	440N-S32047	
						3 m (9.8 ft) cable	440N-S32055
						10 m (32.8 ft) cable	440N-S32056
			1 N.O.	S43	8-pin Micro (M12)	440N-S32046	
						3 m (9.8 ft) cable	440N-S32053
		10 m (32.8 ft) cable	440N-S32054				

(1) Contacts are described with the guard door closed, that is, the actuator in place. Switch is shipped complete with actuator.

Table 94 - Connection Systems



Description	4-pin Micro (M12)	8-pin Micro (M12)
Cordset	889D-F4ECA-x ⁽¹⁾	889D-F8AB-x ⁽¹⁾
Patchcord	889D-F4ECRM-y ⁽²⁾	889D-F8ABDM-y ⁽²⁾

(1) Replace x with 2 (2 m [6.6 ft]), 5 (5 m [16.4 ft]), or 10 (10 m [32.8 ft]) for standard cable lengths.

(2) Replace y with 1 (1 m [3.3 ft]), 2 (2 m [6.6 ft]), 3 (3 m [9.8 ft]), 5 (5 m [16.4 ft]), or 10 (10 m [32.8 ft]) for standard cable lengths.

Recommended Logic Interface

Table 95 - Sensor Logic Interface

Housing	Supply Voltage	Safety Contacts	Auxiliary Contacts	Housing Width [mm (in.)]	Type	Cat. No.
	24V AC/DC	1 N.O.	1 N.C. solid state	22.5 (0.89)	Control Unit 1	440N-S32013
	24V AC/DC; 115/230V AC	2 N.O.	1 N.C.	45 (1.77)	Control Unit 2	440N-S32021
	24V AC/DC; 115/230V AC	2 N.O. and 1 N.O. delayed	1 N.C.	90 (3.54)	Sipha 6	440N-S32052

Accessories

Table 96 - Sensor Accessories

Description	Cat. No.
Actuator S10	440N-A32019
Actuator S20	440N-A32020
Actuator S30	440N-A32025
Actuator S40 (GD2)	440N-A32041
Bag of 40 washers for S2 models	440N-A17127

Approximate Dimensions

Dimensions are not intended to be used for installation purposes.

Figure 46 - Sipha S1 [mm (in.)]

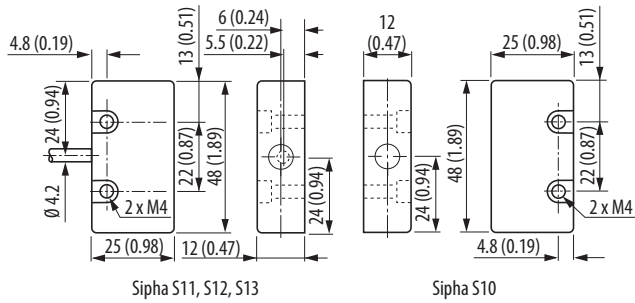

Figure 49 - Siphon S4 [mm (in.)]

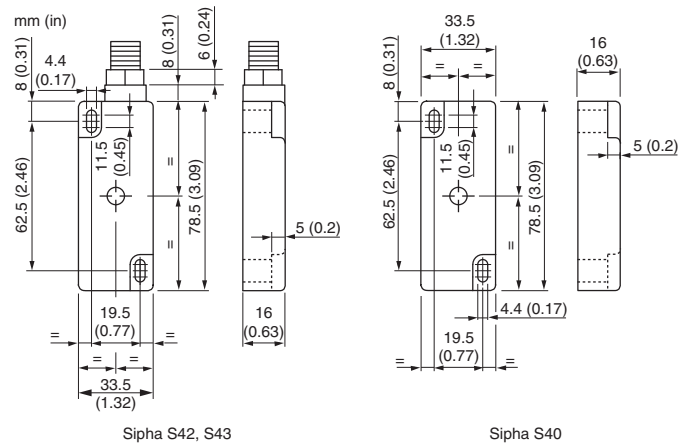
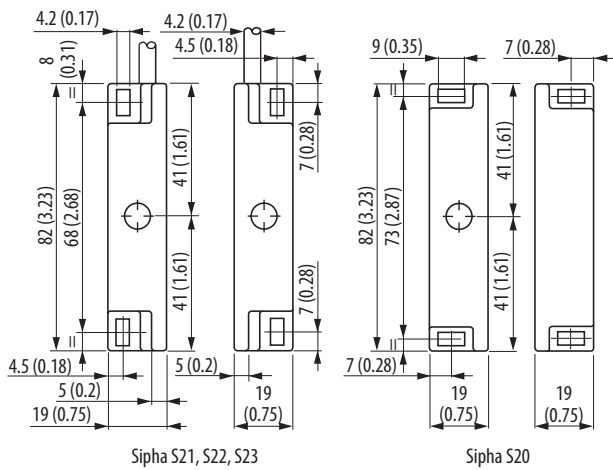

Figure 47 - Siphon S2 [mm (in.)]



Typical Wiring Diagrams

Table 97 - S11, S21, S42, S12, S22, S43, S13, and S23 Wiring

Description		S11 and S21 1 N.O. and 1 N.C.	S42, S12, and S22 2 N.C. and 1 N.O.	S43, S13, and S23 1 N.C. and 2 N.O.
Cable Versions	Red	Safety A_N.C.	Safety A_N.C.	Safety A_N.C.
	Blue			
	Yellow	Safety B_N.O.	Safety B_N.O.	Safety B_N.O.
	Green			
	Black	—	Aux A_N.C.	Aux A_N.O.
	White			
	Green/ Yellow	—	External Ground	External Ground

Figure 48 - Siphon S3 [mm (in.)]

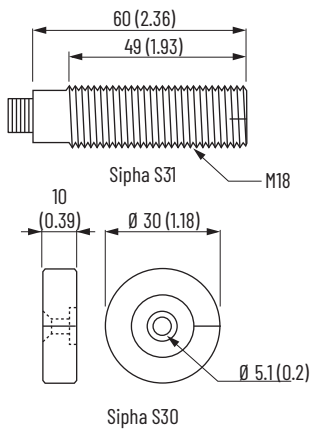





Table 98 - S31, S42, and S43 Wiring

Description		S31	S42	S43
4-pin Micro (M12)			—	—
8-pin Micro (M12)		—		
4-pin Cordset 889D-F4AC-x ⁽¹⁾	Brown	Safety A_N.C.	—	—
	Blue			
	White	Safety B_N.O.	—	—
	Black			
8-pin Cordset 889D-F8AB-x ⁽¹⁾	White Brown	Safety A	Safety A_N.C.	Safety A_N.C.
	Red Yellow	Safety B	Safety B_N.O.	Safety B_N.O.
	Gray Pink	Aux A	Aux A_N.C.	Aux A_N.O.
	Green Blue	—	Gnd	Gnd

(1) Replace x with 2 (2 m [6.6 ft]), 5 (5 m [16.4 ft]) or 10 (10 m [32.8 ft]) for standard cable lengths.

Interlocking Switches - Electromechanical (Voltage-free Contacts)

Elf Miniature Tongue Interlock Switches

The Elf™ miniature tongue interlock switches have the following features:

- Ideal for small, lightweight guards
- The smallest interlock switch available
- Contacts, 2 N.C. or 1 N.O. and 1 N.C.
- Eight possible actuator entry points, easy to install
- Environmental protection: IP67
- GD2 style available for difficult applications

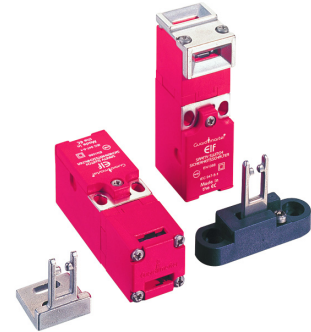

Specifications

Table 99 - Interlock Switch Specifications

Attribute	440K-E			
Safety Ratings				
Standards	ISO 14119, IEC 60947-5-1			
Safety classification	Type 2 interlocking device per ISO 14119			
Functional safety data	See publication SAFETY-SR001			
Certifications	cULus Listed, TÜV Certified, UKCA Marked for all applicable regulations, and CE Marked for all applicable directives rok.auto/certifications			
Outputs				
Safety contacts ⁽¹⁾ Direct opening action	1 N.C.	2 N.C.		
Auxiliary contacts	1 N.O.	None		
Thermal current/ <i>I_{th}</i>	5 A (10 A if A600)			
Rated insulation voltage	2500V			
Switching current at voltage, min	3 mA at 18V DC			
Utilization Category				
A600/AC-15 (Ue)	600V	500V	240V	120V
A600/AC-15 (Ie)	1.2 A	1.4 A	3.0 A	6.0 A
DC-13 (Ue)	24V			
DC-13 (Ie)	2 A			
Operating Characteristics				
Break contact force	6 N (1.35 lbf), min			
Actuation speed, max	160 mm (6.29 in.)/s			
Actuation frequency, max	2 cycles/s			
Operating radius, min	150 mm (5.9 in.) [60 mm (2.36 in.) with GD2 kit]			
Mechanical life	1,000,000 operations			
Environmental				
Enclosure type rating	IP67			
Operating temperature	-20...+80 °C (-4...+176 °F)			
Physical Characteristics				
Material	<ul style="list-style-type: none"> • Housing: UL approved glass-filled PBT • Actuator: Stainless steel 			
Weight	60 g (2.11 oz)			
Color	Red			

(1) The safety contacts are described as normally closed (N.C.) for example, with the guard closed, the actuator in place (where relevant) and the machine able to be started.

Product Selection

Table 100 - Interlock Switch Product Selection

Contact			Actuator Type	Cat. No.			
Safety	Auxiliary	Action		M16 Conduit		Connector ⁽¹⁾	
				M16	1/2 inch NPT Adapter	Connect to Distribution Box 4-pin Micro (M12)	Connect to ArmorBlock Guard I/O 5-pin Micro (M12) ⁽²⁾
1 N.C.	1 N.O.	BBM	Flat	440K-E33036	440K-E33029	440K-E33074	—
			90°	440K-E33040	440K-E33030	440K-E33025	—
			GD2 metal alignment guide w/semi-flexible actuator	440K-E33034	440K-E33031	440K-E33075	—
			—	440K-E33014	440K-E33053	—	—
2 N.C.	—	—	Flat	440K-E33080	440K-E33037	440K-E33077	440K-E2NNFPS
			90°	440K-E33041	440K-E33045	440K-E33024	—
			GD2 metal alignment guide w/semi-flexible actuator	—	440K-E33046	440K-E33078	440K-E2NNAPS
			—	440K-E33047	—	440K-E33079	—

(1) For connector ratings, see [Table 102](#).

(2) With a 5-pin micro (M12) connector, not all contacts are connected. See [Typical Wiring Diagrams on page 76](#) for wiring details.

Table 101 - Connection Systems

Description	Cat. No.		
	Connection to Distribution Box 4-pin Micro (M12)		Connection to ArmorBlock Guard I/O 5-pin Micro (M12)
	1 N.C. and 1 N.O.	2 N.C.	2 N.C.
Cordset	889D-F4AC-x ⁽¹⁾	889D-F4AC-x ⁽¹⁾	—
Patchcord	889D-F4ACDM-y ⁽²⁾	889D-F4ACDM-y ⁽²⁾	889D-F5ACDM-x ⁽¹⁾
Distribution box	898D-4zKT-DM4 ⁽³⁾	898D-4zLT-DM4 ⁽³⁾	—
Shorting plug	898D-41KU-DM	898D-41LU-DM	—
T-port	898D-43KY-D4	898D-43LY-D4	—

(1) Replace x with 2 (2 m [6.6 ft]), 5 (5 m [16.4 ft]), or 10 (10 m [32.8 ft]) for standard cable lengths.

(2) Replace y with 1 (1 m [3.3 ft]), 2 (2 m [6.6 ft]), 3 (3 m [9.8 ft]), 5 (5 m [16.4 ft]), or 10 (10 m [32.8 ft]) for standard cable lengths.



(3) Replace z with 4 or 8 for number of ports.



Table 102 - Connector Ratings

Description	Max Ratings		Applicable Standards
	AC	DC	
4-pin Micro (M12)	250V, 4 A	250V, 4 A	IEC 61076-2-101
5-pin Micro (M12)	60V, 4 A	60V, 4 A	IEC 61076-2-101
6-pin Micro (M12)	30V, 2 A	30V, 2 A	IEC 61076-2-101
8-pin Micro (M12)	30V, 2 A	30V, 2 A	IEC 61076-2-101
12-pin M23	63V, 6 A	63V, 6 A	IEC 61984

Accessories

Table 103 - Interlock Switch Accessories

Description	Cat. No.
 Flat actuator, not to be used with metal alignment guide	440K-A21014
 90° actuator, not to be used with metal alignment guide	440K-A21006
 Metal alignment guide with semi-flexible actuator	440K-A21030

Description	Cat. No.
 Metal alignment guide	440K-A21069
 Replacement cover	440A-A33085
 Dust cover	440K-A17182

Approximate Dimensions

Dimensions are not intended to be used for installation purposes.

Figure 50 - Interlock Switch Dimensions [mm (in.)]

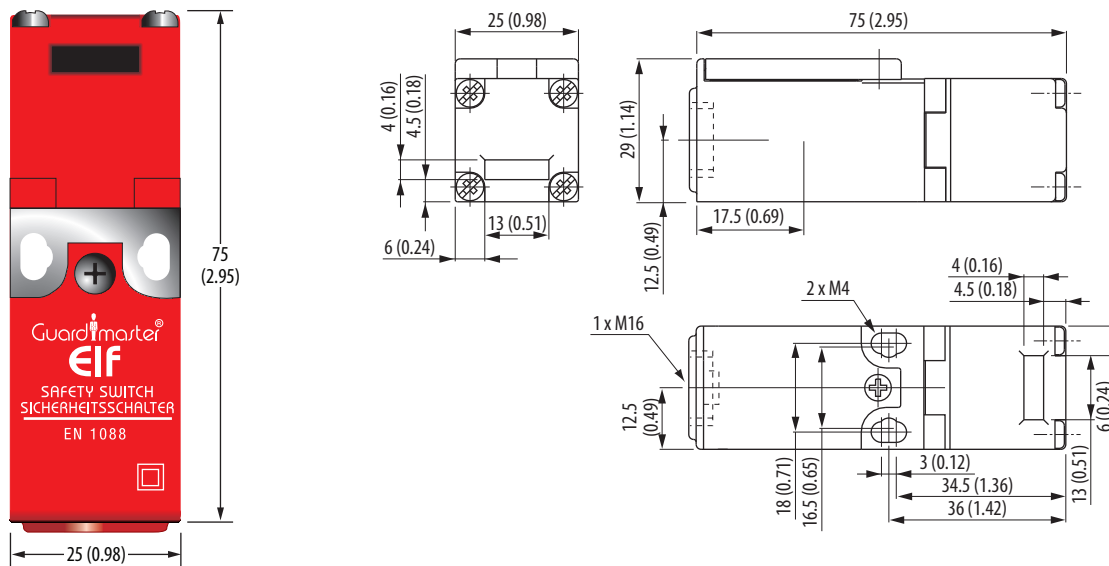

Typical Wiring Diagrams

Table 104 - Interlock Switch Wiring

Description		1 N.C. and 1 N.O.	1 N.C.
Contact Configuration			
Contact Action □ Open ■ Closed			
4-pin Micro (M12)			
5-pin Micro (M12) For ArmorBlock® Guard I/O™		—	
Cordset 889D-F4AC-x ⁽¹⁾	Brown	Safety A	Safety A
	Blue		
	White	Aux A	Safety B
	Black		

(1) Replace x with 2 (2 m [6.6 ft]), 5 (5 m [16.4 ft]), or 10 (10 m [32.8 ft]) for standard cable lengths.

Cadet 3 Tongue Interlock Switches

The Cadet™ 3 tongue interlock switches have the following features:

- Compact size
- Ideal for small, lightweight guards
- Contacts: 2 N.C. and 1 N.O. or 3 N.C.
- Sealed to IP67
- Eight possible actuator entry points, easy to install
- Industry standard fixing centers to DIN 50047
- GD2 style available for difficult applications



Specifications

Table 105 - Interlock Switch Specifications

Attribute	Value			
Safety Ratings				
Standards	ISO 14119, IEC 60947-5-1			
Safety classification	Type 2 Interlocking Device per ISO 14119			
Functional safety data	See publication SAFETY-SR001			
Certifications	cULus Listed, TÜV Certified, UKCA Marked for all applicable regulations, and CE Marked for all applicable directives rok.auto/certifications			
Outputs				
Safety contacts ⁽¹⁾ Direct Opening Action	2 N.C.	3 N.C.		
Auxiliary contacts	1 N.O.	None		
Thermal current/ I_{th}	10 A			
Rated insulation voltage (U_i)	500V			
Switching current at voltage	3 mA at 18V DC, min			
Utilization Category				
A600/AC-15 (Ue)	600V	500V	240V	120V
A600/AC-15 (Ie)	1.2 A	1.4 A	3.0 A	6.0 A
DC-13 (Ue)	24V			
DC-13 (Ie)	2 A			
Operating Characteristics				
Break contact force	15 N (3.37 lbf), min			
Actuation speed, max	160 mm (6.29 in.)/s			
Actuation frequency, max	2 cycles/s			
Operating radius, min	150 mm (5.9 in.) [60 mm (2.36 in.) with GD2 kit]			
Mechanical Life	1,000,000 operations			
Environmental				
Enclosure type rating	IP67			
Operating temperature	-20...+80 °C (-4...+176 °F)			
Physical Characteristics				
Material	<ul style="list-style-type: none"> • Housing: UL approved glass-filled PBT • Actuator: Stainless steel 			
Weight	80 g (0.176 lb)			
Color	Red			

(1) The safety contacts are described as normally closed (N.C.), for example, with the guard closed, the actuator in place (where relevant) and the machine able to be started.

Product Selection

Table 106 - Interlock Switch Product Selection

Contact			Actuator Type	Cat. No.			
Safety	Auxiliary	Action		M16 Conduit		Connector ⁽¹⁾	
				M16	1/2 inch NPT Adapter	Connect to Distribution Box 6-pin Micro (M12)	Connect to ArmorBlock Guard I/O 5-pin Micro (M12) ⁽²⁾
3 N.C.	-	-	Flat	440K-C21096	440K-C21048	440K-C21090	440K-C2NNFPS
			90°	440K-C21097	440K-C21057	440K-C21091	-
			GD2 Metal alignment guide w/semi-flex actuator	-	440K-C21062	440K-C21092	440K-C2NNAPS
			-	440K-C21070	-	-	-
2 N.C.	1 N.O.	BBM	Flat	440K-C21098	440K-C21050	440K-C21054	-
			90°	440K-C21061	440K-C21058	440K-C21067	-
			GD2 metal alignment guide w/semi-flexible actuator	-	440K-C21074	440K-C21088	-
			-	440K-C21055	-	-	-
		MBB	Flat	440K-C21052	440K-C21093	440K-C21060	-
			90°	440K-C21065	440K-C21094	440K-C21068	-
			GD2 Metal alignment guide w/semi-flex actuator	-	440K-C21095	440K-C21089	-
			-	440K-C21080	-	-	-

(1) For connector ratings, see [Table 102 on page 74](#).

(2) With a 5-pin micro (M12) connector, not all contacts are connected. See [Typical Wiring Diagrams on page 80](#) for wiring details.

Table 107 - Connection Systems



Description	Cat. No.	
	6-pin Micro (M12)	5-pin Micro (M12)
Cordset	889R-F6ECA-x ⁽¹⁾	-
Patchcord	889R-F6ECRM-y ⁽²⁾	889D-F5ACDM-x ⁽¹⁾
Distribution box	898R-P68MT-A5	-
Shorting plug	898R-61MU-RM	-



(1) Replace x with 2 (2 m [6.6 ft]), 5 (5 m [16.4 ft]), or 10 (10 m [32.8 ft]) for standard cable lengths.

(2) Replace y with 1 (1 m [3.3 ft]), 2 (2 m [6.6 ft]), 3 (3 m [9.8 ft]), 5 (5 m [16.4 ft]), or 10 (10 m [32.8 ft]) for standard cable lengths.

Accessories

Table 108 - Interlock Switch Accessories

Description	Cat. No.
 Flat actuator, not to be used with metal alignment guide	440K-A21014
 90° actuator, not to be used with metal alignment guide	440K-A21006
 Metal alignment guide with semi-flexible actuator	440K-A21030

Description	Cat. No.
 Replacement cover	440A-A21115
 Dust cover	440K-A17182

Approximate Dimensions

Dimensions are not intended to be used for installation purposes.

Figure 51 - Interlock Switch Dimensions [mm (in.)]

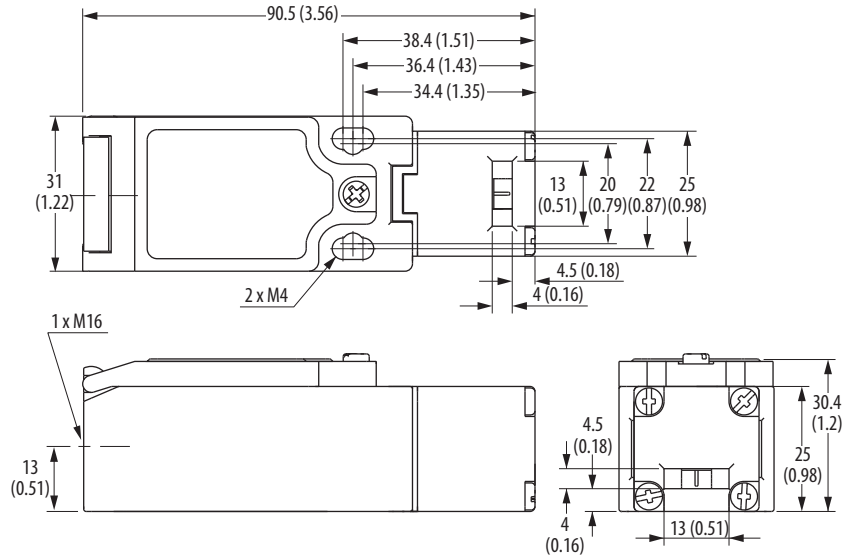

Typical Wiring Diagrams

Table 109 - Interlock Switch Wiring

Description		2 N.C. and 1 N.O.	3 N.C.
Contact Configuration			
Contact Action □ Open ■ Closed			
6-pin Micro (M12)			
5-pin Micro (M12)		—	
Cordset 889R-F6ECA-x ⁽¹⁾	Red/White	Safety A	Safety A
	Red/Black		
	Red	Safety B	Safety B
	Red/Blue		
	Green	Aux A	Safety C
Red/Yellow			

(1) Replace x with 2 (2 m [6.6 ft]), 5 (5 m [16.4 ft]), or 10 (10 m [32.8 ft]) for standard cable lengths.

Trojan T15 Tongue Interlock Switches

The Trojan™ T15 tongue interlock switches have the following features:

- Compact size, 75 x 52 x 32 mm (2.95 x 2.05 x 1.26 in.) case.
- 30 N actuator retention force
- Strong and versatile, can be used in most applications.
- Contacts: 2 N.C. safety or 1 N.C. safety and 1 N.O. auxiliary.
- GD2 style available for difficult applications

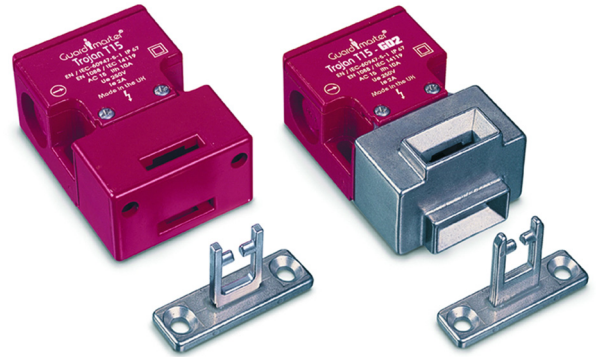

Specifications

Figure 52 - Interlock Switch Specifications

Attribute	Value			
Safety Ratings				
Standards	ISO 14119, IEC 60947-5-1			
Safety classification	Type 2 Interlocking Device per ISO 14119			
Functional safety data	See publication SAFETY-SR001			
Certifications	cULus Listed, TÜV Certified, UKCA Marked for all applicable regulations, and CE Marked for all applicable directives rok.auto/certifications			
Outputs				
Safety contacts ⁽¹⁾ Direct opening action	2 N.C.			2 N.C.
Auxiliary contacts	None			1 N.O.
Thermal current/ I_{th}	10 A			
Rated insulation voltage (U_i)	2500V			
Switching current at voltage	3 mA at 18V DC, min			
Utilization Category				
A600/AC-15 (Ue)	600V	500V	240V	120V
A600/AC-15 (Ie)	1.2 A	1.4 A	3.0 A	6.0 A
DC-13 (Ue)	24V			
DC-13 (Ie)	2 A			
Operating Characteristics				
Break contact force	30 N (6.70 lbf), min			
Actuation speed, max	160 mm (6.29 in.)/s			
Actuation frequency, max	2 cycles/s			
Operating radius, min	175 mm (6.89 in.) [60 mm (2.36 in.) with GD2 kit]			
Mechanical life	1,000,000 operations			
Environmental				
Enclosure type rating	IP67			
Operating temperature	-20...+80 °C (-4...+176 °F)			
Physical Characteristics				
Material	<ul style="list-style-type: none"> • Housing: UL approved glass-filled PBT • Actuator: Stainless steel 			
Weight	120 g (0.265 lb)			
Color	Red			

(1) The safety contacts are described as normally closed (N.C.) for example, with the guard closed, the actuator in place (where relevant) and the machine able to be started.

Product Selection

Table 110 - Interlock Switch Product Selection

Type	Contact		Contact Action	Actuator Type	Cat. No.			
	Safety	Auxiliary			M20 Conduit		Connector ⁽¹⁾	
					M20	1/2 inch NPT Adapter	Connect to Distribution Box 4-pin Micro (M12)	Connect to ArmorBlock Guard I/O 5-pin Micro (M12)
Trojan T15 standard switch	2 N.C.	—	—	Standard	440K-T11303	440K-T11267	440K-T11307	440K-V2NNSPS
				Fully flexible	440K-T11395	440K-T11273	440K-T11384	440K-V2NNBPS
				—	440K-T11269	—	440K-T11385	—
	1 N.C.	1 N.O.	BBM	Standard	440K-T11305	440K-T11268	440K-T11386	—
				Fully flexible	440K-T11396	440K-T11276	440K-T11387	—
				—	440K-T11270	—	440K-T11388	—
Trojan T15 GD2 switch	2 N.C.	—	—	GD2 standard	440K-T11463	440K-T11288	440K-T11389	440K-V2NNGPS-NG
				Fully flexible	440K-T11397	440K-T11287	440K-T11390	—
				—	440K-T11280	—	440K-T11391	—
	1 N.C.	1 N.O.	BBM	GD2 standard	440K-T11398	440K-T11284	440K-T11392	—
				Fully flexible	440K-T11399	440K-T11283	440K-T11393	—
				—	440K-T11279	—	440K-T11394	—

(1) For connector ratings, see [Table 102 on page 74](#).

Table 111 - Connection Systems

Description	Cat. No.		
	Connection to Distribution Box 4-pin Micro (M12)		Connection to ArmorBlock Guard I/O 5-pin Micro (M12)
	1 N.C. and 1 N.O.	2 N.C.	2 N.C.
Cordset	889D-F4AC-x ⁽¹⁾	889D-F4AC-x ⁽¹⁾	—
Patchcord	889D-F4ACDM-y ⁽²⁾	889D-F4ACDM-y ⁽²⁾	889D-F5ACDM-x ⁽¹⁾
Distribution box	898D-4zKT-DM4 ⁽³⁾	898D-4zLT-DM4 ⁽³⁾	—
Shorting plug	898D-41KU-DM	898D-41LU-DM	—
T-port	898D-43KY-D4	898D-43LY-D4	—

(1) Replace x with 2 (2 m [6.6 ft]), 5 (5 m [16.4 ft]), or 10 (10 m [32.8 ft]) for standard cable lengths.

(2) Replace y with 1 (1 m [3.3 ft]), 2 (2 m [6.6 ft]), 3 (3 m [9.8 ft]), 5 (5 m [16.4 ft]), or 10 (10 m [32.8 ft]) for standard cable lengths.

(3) Replace z with 4 or 8 for number of ports.

Accessories

Table 112 - Interlock Switch Accessories

Description	To Be Used With	Cat. No.
	Standard actuator	Trojan T15 standard models only
	GD2 standard actuator	Trojan GD2 models only
	GD2 flat actuator	Trojan GD2 models only
	Alignment guide with semi-flexible actuator	Discard alignment guide for GD2 models
	Alignment guide with fully flexible actuator	Discard alignment guide for GD2 models
	Sliding bolt actuator	Trojan GD2 models only
	Catch and retainer kit	Trojan T15 standard models only
	Replacement cover	All models
	Dust cover	All models

Approximate Dimensions

Dimensions are not intended to be used for installation purposes.

Figure 53 - Interlock Switch Dimensions [mm (in.)]

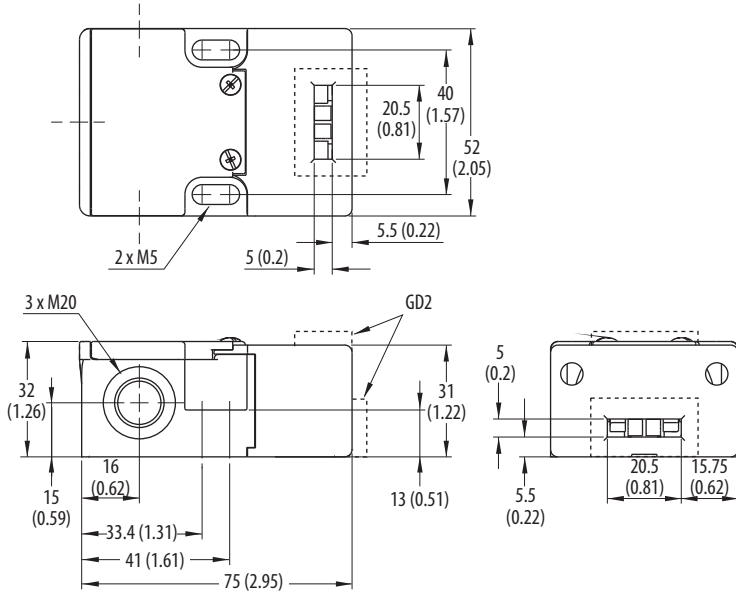

Typical Wiring Diagrams

Table 113 - Interlock Switch Wiring

Description		1 N.C. and 1 N.O.	1 N.C.
Contact Configuration			
Contact Action □ Open ■ Closed			
4-pin Micro (M12)			
5-pin Micro (M12)		—	
Cordset 889D-F4AC-x ⁽¹⁾	Brown	Safety A	Safety A
	Blue		
	White	Aux A	Safety B
	Black		

(1) Replace x with 2 (2 m [6.6 ft]), 5 (5 m [16.4 ft]), or 10 (10 m [32.8 ft]) for standard cable lengths.

Trojan 5 and 6 Universal Tongue Interlock Switches

The Trojan 5 and 6 Universal Tongue Interlock Switches have the following features:

- Strong and versatile, can be used in most applications
- Self-ejecting tamper resistant actuator, only operates when mounted to the guard (not with GD2 models)
- Four possible actuator entry points, easy to install
- GD2 style available for difficult applications



Specifications

Table 114 - Interlock Switch Specifications

Attribute	Value			
Safety Ratings				
Standards	ISO 14119, IEC 60947-5-1			
Safety classification	Type 2 Interlocking Device per ISO 14119			
Functional safety data	See publication SAFETY-SR001			
Certifications	cULus Listed, TÜV Certified, UKCA Marked for all applicable regulations, and CE Marked for all applicable directives rok.auto/certifications			
Outputs				
Safety contacts ⁽¹⁾ Direct opening action	3 N.C.	2 N.C.	2 N.C.	
Auxiliary contacts	1 N.O.	2 N.O.	1 N.O.	
Thermal current/ I_{th}	10 A			
Rated insulation voltage (U_i)	500V			
Switching current at voltage	3 mA at 18V DC, min			
Utilization Category: Trojan 5 Switch				
A300/AC-15 (U_e)	240V	120V		
A300/AC-15 (I_e)	3 A	6 A		
DC-13 (U_e)	24V	24V		
DC-13 (I_e)	2 A			
Utilization Category: Trojan 6 Switch				
A600/AC-15 (U_e)	600V	500V	240V	120V
A600/AC-15 (I_e)	1.2 A	1.4 A	3 A	6 A
DC-13 (U_e)	24V			
DC-13 (I_e)	2 A			
Operating Characteristics				
Break contact force				
Trojan 5 switch	12 N (2.7 lbf) and 30 N (6.75 lbf)			
Trojan 6 switch	20 N (4.5 lbf)			
Actuation speed, max	160 mm (6.29 in.)/s			
Actuation frequency, max	2 cycles/s			
Operating radius, min	175 mm (6.89 in.) [60 mm (2.36 in.) with flexible actuator]			
Mechanical life	1,000,000 operations			
Environmental				
Enclosure type rating	IP67			
Operating temperature	-20...+80 °C (-4...+176 °F)			
Physical Characteristics				
Material	<ul style="list-style-type: none"> • Housing: UL approved glass-filled PBT • Actuator: Stainless steel 			
Weight	160 g (0.35 lb)			
Color	Red			

(1) The safety contacts are described as normally closed (N.C.) for example, with the guard closed, the actuator in place (where relevant) and the machine able to be started.

Product Selection

Table 115 - Trojan 5 Switch

Type	Contact			Actuator Type	Cat. No.						
	Safety	Auxiliary	Action		M20 Conduit		Connector ⁽¹⁾				
					M20	1/2 inch NPT Adapter	5-pin Micro (M12) QD ⁽²⁾	6-pin Micro (M12) QD			
Trojan 5 standard switch	2 N.C.	1 N.O.	BBM	Standard	440K-T11090	440K-T11202	440K-T11205	—			
				Guide/semi-flexible	440K-T11110	440K-T11203	440K-T11206	—			
				Guide/fully flexible	440K-T11467	440K-T11204	440K-T11207	440K-T2NNBPS			
				—	440K-T11089	—	440K-T11129	—			
			BBM Gold Contacts	Standard	440K-T11085	—	—	—			
				MBB	Standard	440K-T11118	440K-T11208	440K-T11224	—		
					Guide/semi-flexible	440K-T11123	440K-T11209	440K-T11363	—		
			Guide/fully flexible		440K-T11468	440K-T11210	440K-T11364	—			
			Trojan 5 GD2 switch	2 N.C.	1 N.O.	BBM	GD2 standard	440K-T11336	440K-T11211	440K-T11366	440K-T2NNGPS-NG
							Guide/semi-flexible	440K-T11337	440K-T11212	440K-T11367	—
Guide/fully flexible	440K-T11338	440K-T11213					440K-T11368	—			
—	440K-T11147	—					440K-T11226	—			
MBB	GD2 standard	440K-T11339				440K-T11470	440K-T11369	—			
	Guide/semi-flexible	440K-T11340				440K-T11471	440K-T11370	—			
	Guide/fully flexible	440K-T11341				440K-T11472	440K-T11371	—			
	—	440K-T11167				—	440K-T11372	—			
Trojan 5 30 N switch			BBM	Standard	440K-T11333	440K-T91024	440K-T11492	—			

(1) For connector ratings, see [Table 102 on page 74](#).

(2) With a 5-pin micro (M12) connector, not all contacts are connected. See [Typical Wiring Diagrams on page 89](#) for wiring details.

Table 116 - Trojan 6 Switch

Type	Contact			Actuator Type	Cat. No.		
	Safety	Auxiliary	Action		M20 Conduit		Connector ⁽¹⁾
					M20	1/2 inch NPT Adapter	8-pin Micro (M12) ⁽²⁾
Trojan 6 switch	3 N.C.	1 N.O.	BBM	Standard	440K-T11171	440K-T11435	—
				—	440K-T11449	440K-T11408	—
	2 N.C.	2 N.O.	BBM	Standard	440K-T11174	440K-T11438	—
				—	440K-T11452	440K-T11416	440K-W21BNPH
		MBB	—	440K-T11453	440K-T11454	440K-W21MNP	
Trojan 6 GD2 switch	3 N.C.	1 N.O.	BBM	GD2 standard	440K-T11418	440K-T11466	—
				—	440K-T11188	440K-T11444	—
			MBB	—	440K-T11456	440K-T11457	—
	2 N.C.	2 N.O.	BBM	GD2 standard	440K-T11445	440K-T11425	—
				—	440K-T11459	440K-T11433	440K-W21BNPH-NG
			MBB	—	440K-T11460	440K-T11461	440K-W21MNP-NG

(1) For connector ratings, see [Table 102 on page 74](#).

(2) With an 8-pin micro (M12) connector, not all contacts are connected. See [Typical Wiring Diagrams on page 89](#) for wiring details.

Table 117 - Connection Systems









Description	Cat. No.		
	Trojan 5 Switch		Trojan 6 Switch
	5-pin Micro (M12)	6-pin Micro (M12)	8-pin Micro (M12)
Cordset	—	889R-F6ECA-x ⁽¹⁾	889D-F8AB-x ⁽¹⁾
Patchcord	889D-F5ACDM-x ⁽¹⁾	889R-F6ECRM-y ⁽²⁾	889D-F8ABDM-y ⁽²⁾
Distribution box	—	898R-P68MT-A5	—
Shorting plug	—	898R-61MU-RM	—
T-port	—	—	—

(1) Replace x with 2 (2 m [6.6 ft]), 5 (5 m [16.4 ft]), or 10 (10 m [32.8 ft]) for standard cable lengths.

(2) Replace y with 1 (1 m [3.3 ft]), 2 (2 m [6.6 ft]), 3 (3 m [9.8 ft]), 5 (5 m [16.4 ft]), or 10 (10 m [32.8 ft]) for standard cable lengths.

Accessories

Table 118 - Interlock Switch Accessories

Description	To Be Used With	Cat. No.
 Standard actuator	Trojan 5 and Trojan 6. Not to be used with GD2 models	440K-A11095
 GD2 standard actuator	GD2 models only	440G-A27011
 GD2 flat actuator	GD2 models only	440K-A11112
 Alignment guide with semi-flexible actuator	Discard alignment guide for GD2 models	440K-A11144
 Alignment guide with fully flexible actuator	Discard alignment guide for GD2 models	440K-A27010
 Sliding bolt actuator	GD2 models only	440G-A27163
 Catch and retainer kit	Trojan 5 and Trojan 6. Not to be used with GD2 models.	440K-A11094
 Replacement cover	Trojan T5 standard model only	440A-A11495
	Trojan T5 GD2	440A-A11496
	Trojan T6 standard model only	440A-A11497
	Trojan T6 GD2	440A-A11498
 Dust cover	All models	440K-A17180

Approximate Dimensions

Dimensions are not intended to be used for installation purposes.

Figure 54 - Standard Model [mm (in.)]

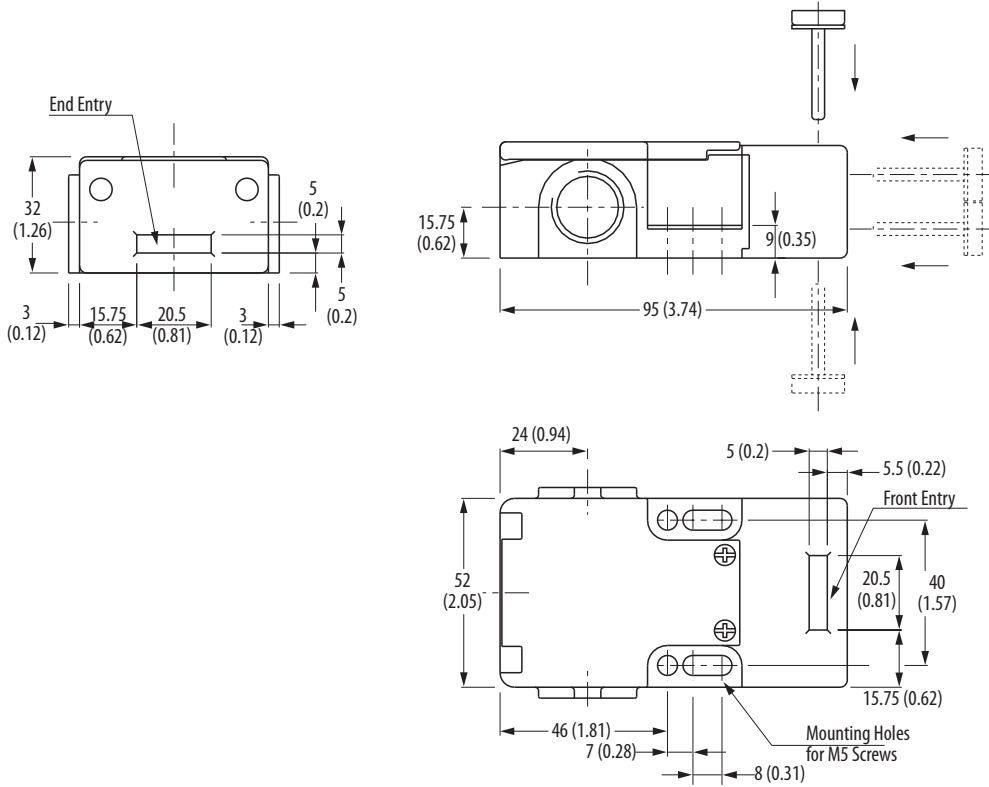
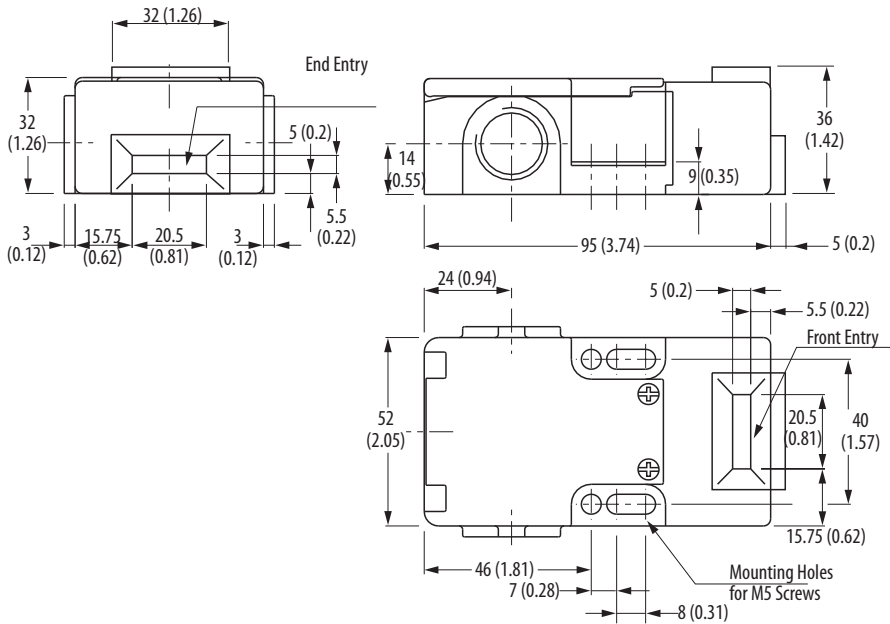
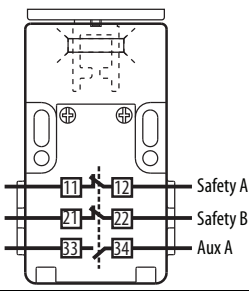
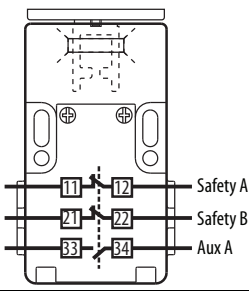
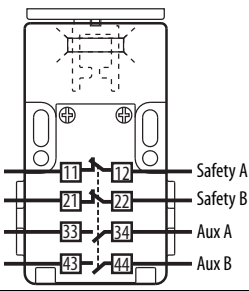
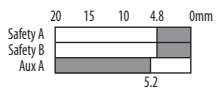
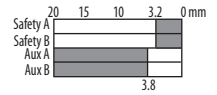
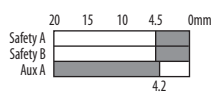
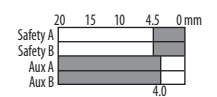
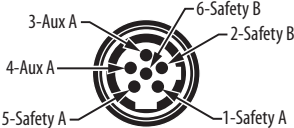
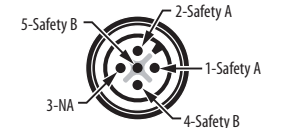
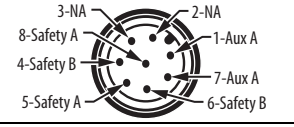

Figure 55 - GD2 Model [mm (in.)]



Typical Wiring Diagrams

Table 119 - Interlock Switch Wiring

Description	Trojan 5		Trojan 6	
	2 N.C. and 1 N.O.		2 N.C. and 2 N.O.	
Contact Configuration 				
Contact Action □ Open ■ Closed	 <p>BBM</p>		 <p>BBM</p>	
	 <p>MBB</p>		 <p>MBB</p>	
6-pin Micro (M12)			-	
5-pin Micro (M12) for ArmorBlock Guard I/O			-	
8-pin Micro (M12)	-			
6-pin Cordset 889R-F6ECA-x ⁽¹⁾	Red/White	Safety A		-
	Red/Black	-		-
	Red	Safety B		-
	Red/Blue	-		-
	Green	Aux		-
8-pin Cordset 889D-F8AB-x ⁽¹⁾	Gray Red	-		Safety A
	Yellow Pink	-		Safety B
	White Blue	-		Aux A
	Green Brown	-		-

(1) Replace x with 2 (2 m [6.6 ft]), 5 (5 m [16.4 ft]), or 10 (10 m [32.8 ft]) for standard cable lengths.

MT-GD2 Tongue Interlock Switches

The MT-GD2 tongue interlock switches have the following features:

- Strong and versatile, can be used in most applications
- Eight possible actuator entry points, easy to install
- Variety of contact configurations
- Snap acting MT-GD2 switch gives a minimum break contact force of 40 N
- Optional latch release styles
- Industry standard fixing centers to DIN/EN50041

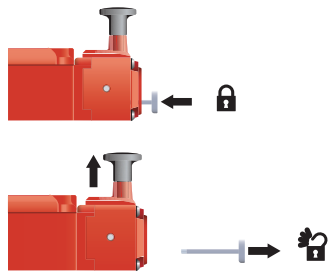
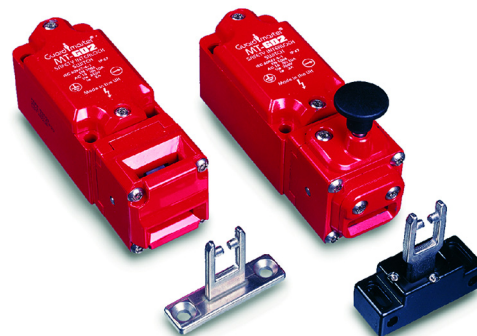

MT-GD2 Latch Release Style

Specifications

Table 120 - Interlock Switch Specifications

Attribute	Value			
Safety Ratings				
Standards	ISO 14119, IEC 60947-5-1			
Safety classification	Type 2 Interlocking Device per ISO 14119			
Functional safety data	See publication SAFETY-SR001			
Certifications	cULus Listed, TÜV Certified, UKCA Marked for all applicable regulations, and CE Marked for all applicable directives rok.auto/certifications			
Outputs				
Safety contacts ⁽¹⁾	<ul style="list-style-type: none"> • Standard: 3 N.C. or 2 N.C. direct opening action • Snap acting: 2 N.C. direct opening forced disconnection 			
Auxiliary Contacts				
Standard	1 N.O. or 2 N.O.			
Snap acting	2 N.O.			
Thermal current/ I_{th}	10 A			
Rated insulation voltage (U_i)	500V			
Switching current at voltage	3 mA at 18V DC, min			
Utilization Category				
A600/AC-15 (Ue)	600V	500V	240V	120V
A600/AC-15 (Ie)	1.2 A	1.4 A	3.0 A	6.0 A
Standard: DC-13 (Ue)	24V			
Standard: DC-13 (Ie)	2 A			
Snap-acting: A300/AC-15 (Ue)	240V	120V		
Snap-acting: A300/AC-15 (Ie)	3 A	6 A		
Snap-acting: DC-13 (Ue)	24V			
Snap-acting: DC-13 (Ie)	2 A			

Table 120 - Interlock Switch Specifications (Continued)

Attribute	Value
Operating Characteristics	
Break contact force, min	
BBM and MBB	12 N (2.7 lbf)
BBM and extended flat actuator	32 N (7.2 lbf)
Snap acting	40 N (9.0 lbf)
Actuation speed, max	160 mm (6.29 in.)/s
Actuation frequency, max	2 cycles/s
Mechanical life	1,000,000 operations
Environmental	
Enclosure type rating	IP67
Operating temperature	-20...+80 °C (-4...+176 °F)
Physical Characteristics	
Material	<ul style="list-style-type: none"> • Housing: Painted zinc • Actuator: Stainless steel
Weight	520 g (1.15 lb)
Color	Yellow or red

(1) The safety contacts are described as normally closed (N.C.) for example, with the guard closed, the actuator in place (where relevant) and the machine able to be started.

Product Selection

Table 121 - Red Body Switches

Type	Contact			Actuator Type	Cat. No.					
	Safety	Auxiliary	Action		Conduit		Connector ⁽¹⁾			
					M20	1/2 inch NPT	12-pin M23	8-pin Micro (M12) ⁽²⁾	Connect to ArmorBlock Guard I/O 5-pin Micro (M12) ⁽³⁾	
MT-GD2	3 N.C.	1 N.O.	BBM	—	440K-MT55002	440K-MT55085	440K-MT55094	—	—	
				GD2 standard	440K-MT55074	440K-MT55022	440K-MT55095	—	—	
				Fully flexible	440K-MT55075	440K-MT55029	440K-MT55096	—	—	
			MBB	—	440K-MT55004	440K-MT55088	440K-MT55100	—	—	
				—	440K-MT55005	440K-MT55086	440K-MT55097	440K-M21BNDH	—	
				GD2 standard	440K-MT55076	440K-MT55026	440K-MT55098	—	—	
	2 N.C.	2 N.O.	BBM	Fully flexible	440K-MT55077	440K-MT55087	440K-MT55099	—	—	
				MBB	—	440K-MT55006	440K-MT55089	440K-MT55101	—	—
				—	—	440K-M22ANDT	440K-M22ANDL	440K-M21ANDH	440K-M2NNDS	
			Snap Acting	Extended flat	440K-M22AEDM	440K-M22AEDT	—	—	—	
				GD2 standard	440K-M22ASDM	440K-M22ASDT	—	—	—	
				Fully flexible	440K-M22ABDM	440K-M22ABDT	—	—	—	
				—	440K-MT55039	440K-MT55062	440K-MT55042	—	—	
				GD2 standard	440K-MT55078	440K-MT55041	440K-MT55070	—	—	
MT-GD2 latch release	3 N.C.	1 N.O.	BBM	Fully flexible	440K-MT55079	440K-MT55045	440K-MT55103	—	—	
				MBB	—	440K-MT55082	440K-MT55091	440K-MT55106	—	—
				—	440K-MT55063	440K-MT55065	440K-MT55066	440K-M21BNDH-N5	440K-M2NNDS-N5	
			BBM	GD2 standard	440K-MT55080	440K-MT55050	440K-MT55104	—	—	
				Fully flexible	440K-MT55081	440K-MT55051	440K-MT55052	—	—	
				MBB	—	440K-MT55083	440K-MT55092	440K-MT55105	440K-M21MNDH-N5	—

(1) For connector ratings, see [Table 102 on page 74](#).

(2) With an 8-pin micro (M12) connector, not all contacts are connected. See [Typical Wiring Diagrams on page 93](#) for wiring details.

(3) With a 5-pin micro (M12) connector, not all contacts are connected. See [Typical Wiring Diagrams on page 93](#) for wiring details.

Table 122 - Yellow Body Switches

Type	Contact			Actuator Type	Cat. No.		
	Safety	Auxiliary	Action		Conduit	Connector ⁽¹⁾	
					1/2-inch NPT	12-pin M23	5-pin Micro (M12) ⁽²⁾
MT-GD2	2 N.C.	2 N.O.	Snap Acting	—	440K-M22ANYT	—	—
				Extended flat	440K-M22AEYT	440K-M22AEYL	440K-M2NAEYS
—	2 N.C.	2 N.O.	MBB	—	440K-M22MNYT-N5	—	440K-M2NNYS-N5

(1) For connector ratings, see [Table 102 on page 74](#).

(2) With a 5-pin micro (M12) connector, not all contacts are connected. See [Typical Wiring Diagrams on page 93](#) for wiring details.

Table 123 - Connection Systems

Description	Cat. No.			
	4-pin Micro (M12)	5-pin Micro (M12)	8-pin Micro (M12)	12-pin M23
Cordset	889D-F4AC-x ⁽¹⁾	—	889D-F8AB-x ⁽¹⁾	889M-F12X9AE-x ⁽¹⁾
Patchcord	889D-F4ACDM-y ⁽²⁾	889D-F5ACDM-x ⁽¹⁾	889D-F8ABDM-y ⁽²⁾	—
Distribution box	889D-P4zLT-DM4 ⁽³⁾	—	—	—
Shorting plug	898D-41LU-DM	—	—	—
T-port	898D-43LY-D4	—	—	—



(1) Replace x with 2 (2 m [6.6 ft]), 5 (5 m [16.4 ft]), or 10 (10 m [32.8 ft]) for standard cable lengths.



(2) Replace y with 1 (1 m [3.3 ft]), 2 (2 m [6.6 ft]), 3 (3 m [9.8 ft]), 5 (5 m [16.4 ft]), or 10 (10 m [32.8 ft]) for standard cable lengths.

(3) Replace z with 4 or 8 for number of ports.

Accessories

Table 124 - Interlock Switch Accessories

Description	Cat. No.
 GD2 standard actuator	440G-A27011
 GD2 flat actuator	440K-A11112
 Fully flexible actuator	440G-A27143

Description	Cat. No.
 Sliding bolt actuator	440G-A27163
 Extended flat actuator	440K-A17116
 Dust cover	440K-A17180

Approximate Dimensions

Dimensions are not intended to be used for installation purposes.

Figure 56 - MT-GD2 [mm (in.)]

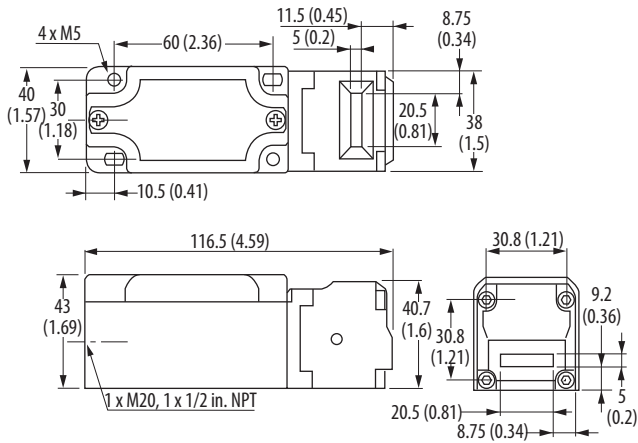
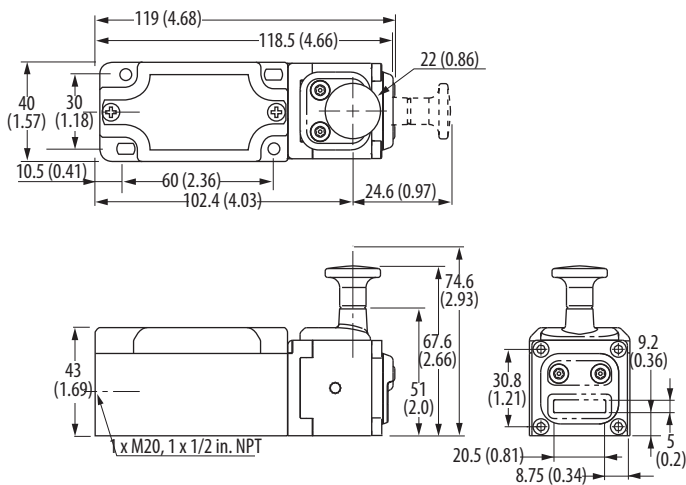

Figure 57 - MT-GD2 Latch Release [mm (in.)]



Typical Wiring Diagrams

Table 125 - Interlock Switch Wiring

Description		2 N.C. and 1 N.O.	2 N.C. and 2 N.O.	3 N.C. and 1 N.O.
Contact Configuration				
Contact Action □ Open ■ Closed				
		—		
		—		—
5-pin Micro (M12) for ArmorBlock Guard I/O		—		—
8-pin Micro (M12)		—		—
12-pin Cordset  Pins 2, 5 and 11 are not connected.	1 and 3	Safety A	Safety A	Safety A
	4 and 6	Safety B	Safety B	Safety B
	7 and 8	NC	Aux A	Safety C
	9 and 10	Aux A	Aux B	Aux A
	12	Ground	Ground	Ground
8-pin Cordset 889D-F8AB-x ⁽¹⁾	Gray Red	—	Safety A	—
	Yellow Pink	—	Safety B	—
	White Blue	—	Aux A	—
	Green	—	Ground	—
	Brown	—	Not Used	—

Table 125 - Interlock Switch Wiring (Continued)

Description		2 N.C. and 1 N.O.	2 N.C. and 2 N.O.	3 N.C. and 1 N.O.
12-pin Cordset 889M-F12X9AE-x ⁽¹⁾	Brown Blue	Safety A	Safety A	Safety A
	White Green	Safety B	Safety B	Safety B
	Yellow Gray	Not Used	Aux A	Safety C
	Pink Red	Aux A	Aux B	Aux A
	Green/Yellow	Ground	Ground	Ground

(1) Replace x with 2 (2 m [6.6 ft]), 5 (5 m [16.4 ft]), or 10 (10 m [32.8 ft]) for standard cable lengths.

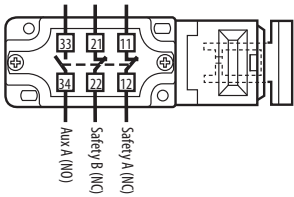
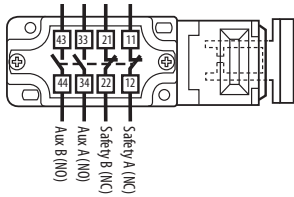
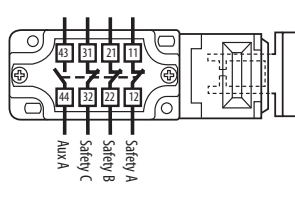
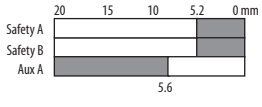
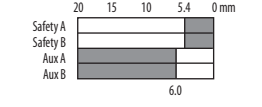
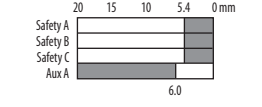
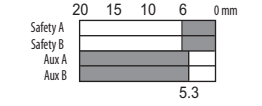
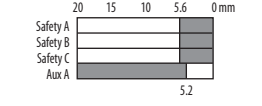
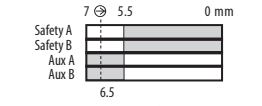
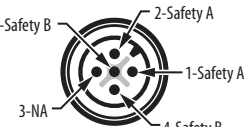
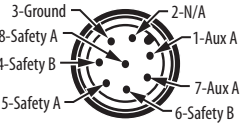
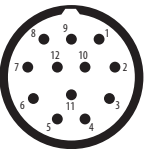

Overview

Trapped key interlock switches can be configured to provide that a predetermined sequence of events takes place or that hazards have been reduced before operators can become exposed to them.

Trapped key interlock switches have the following features:

- Stainless-steel construction
- 90° key operation
- Compact, solid, and sturdy keys supplied with dust seals and coded tagging

Design Suggestions for an Interlocking System

Figure 58 - Plant and Machinery Interlocking

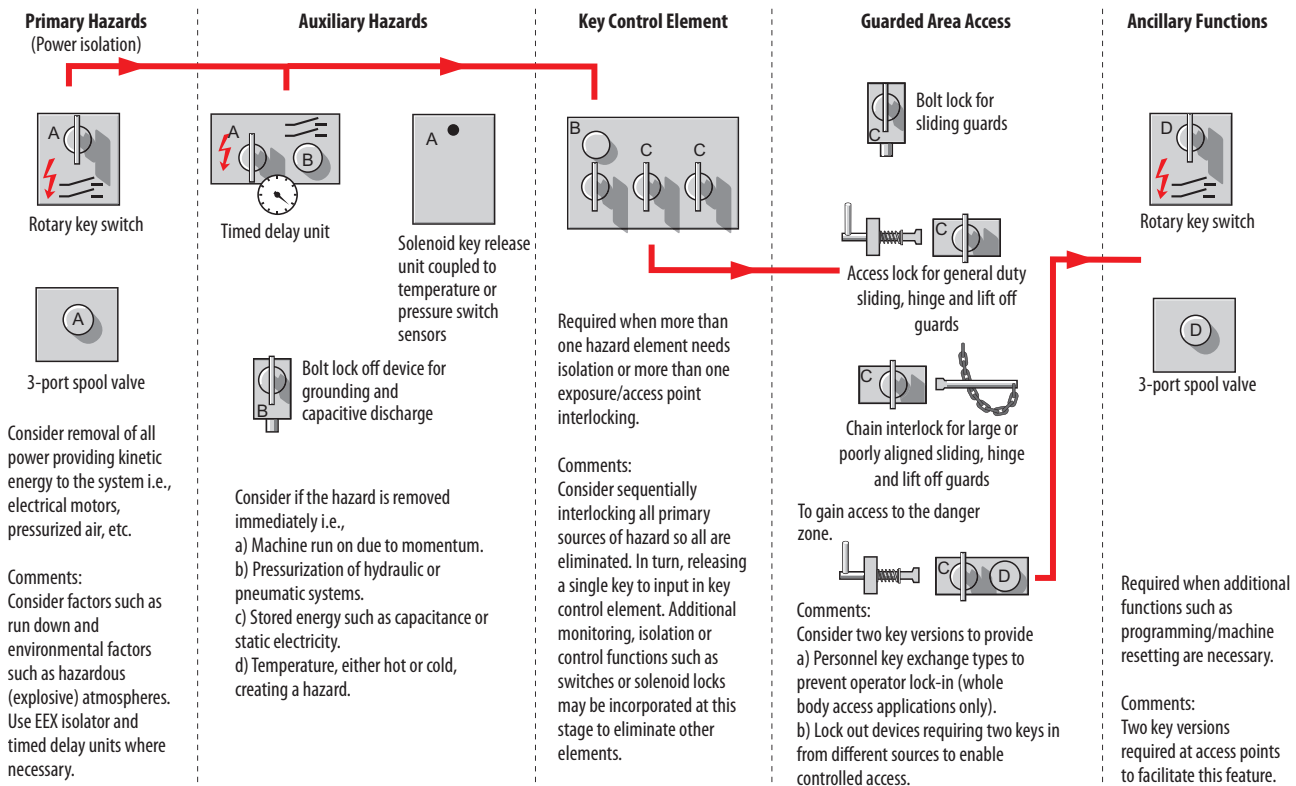
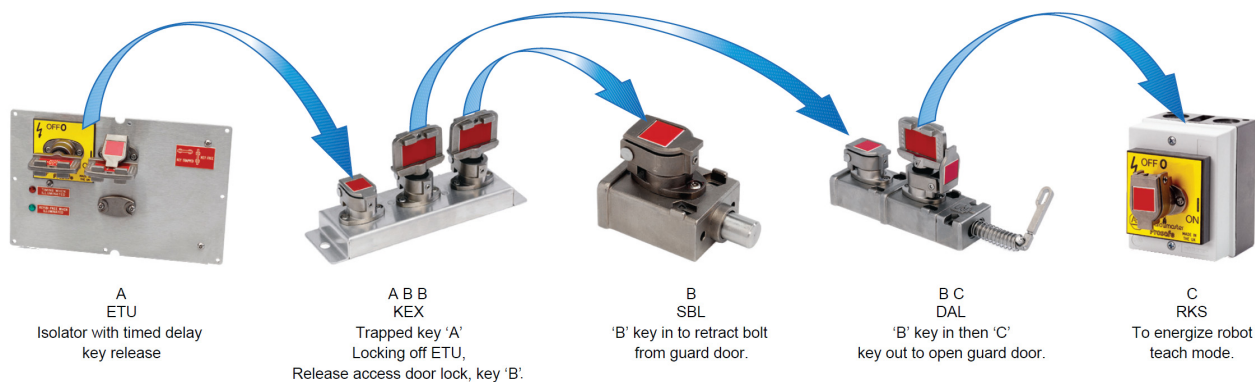

Figure 59 - Illustrated Principals of Trapped Key Interlocking



1. The Electronic Timed-delay Unit (ETU) isolator has two keys. One is a nonremovable key. The other key (an A coded key) can be removed after a timed duration, which a potentiometer inside the ETU isolator sets. Turn the nonremovable key to turn off the hazardous machine motion and start the timer. When the time expires, the Key Free light-emitting diode turns ON. Remove the A key.
2. Insert the A key into the Key Exchange Unit (KEX) and turn it 90°.
3. Turn one of the B keys 90° and remove it from the KEX. This action traps the A key in the KEX and helps prevent the restarting of the machine.
4. Insert the B key into the Single-key Bolt Lock (SBL) and turn it 90° to gain partial body access to the machine.
5. Turn the second B key 90° and remove it from the KEX. Removal of this key also traps the A key in the KEX and helps prevent the restarting of the machine.
6. Insert the B key into the Dual-key Access Lock (DAL) and turn it 90°.
7. Turn the C key 90° and remove the C key. To allow full body entry into the hazardous zone, rotate the access handle.
8. Take the C key into the hazardous zone, insert it into the rotary keyswitch (RKSE), and turn it 90° to send a signal to the machine control system that allows the machine to operate in a slow or teach mode.
9. To return the machine to full operational mode, reverse the process.

Table 126 - Bill of Materials

Item	Quantity	Description	Cat. No.
1	1	Single key time delayed with an A primary key	440T-MSTUE110A
2	1	Exchange unit, B primary key, two B secondary keys trapped (included)	440T-MKXE110A0B0B
3	1	Single bolt lock, B primary key	440T-MSBLE100B
4	1	Dual access lock, B primary key, C secondary key trapped (included)	440T-MDALE100B0C
5	1	Rotary keyswitch, C primary code barrel	440T-MRKSE100C
6	1	A key	440T-AKEYE100A

Primary keys must be ordered separately, when not provided for by a previous sequential trapped key. In the previous example, only one primary key must be ordered separately. The remaining primary keys are provided by a previous sequential secondary (trapped) key.

Application Examples

Figure 60 - Part Body Access

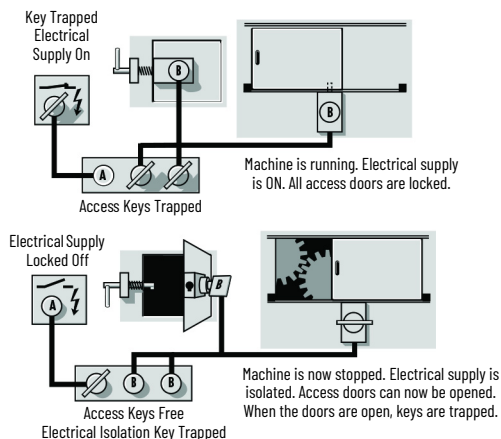
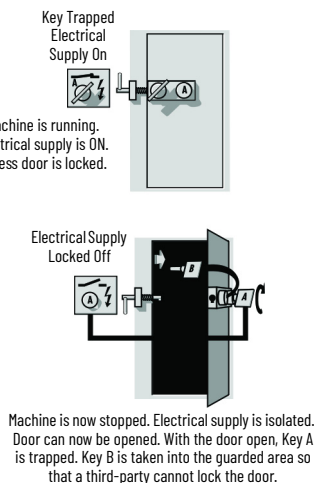

Figure 61 - Full Body Access



Code Selection

To order Prosafe® trapped key products, you must include codes in the catalog number.

- The codes are added to the end of the catalog number.
- Each code must be two or three characters in length.
- The first code is the primary code and the last codes, if necessary, are the secondary codes.
- Primary codes are not included. The key must be ordered separately or must come from a previous operation.
- Secondary codes come with the product, as the key is trapped in the code barrel.
- Use [Table 129 on page 99](#) to select and track codes.

Table 127 - Order Example 1

440T	-	M	DALE	10	AA	AB
a		b	c	d	e	f

a	
Code	Description
440T	Bulletin number

b	
Code	Description
A	Accessory
M	Machine interlock

c	
Code	Description
DALE	Dual-key access lock

d	
Code	Description
10	Product feature

e	
Code	Description
AA	Primary code ^{(1) (2)}

f	
Code	Description
AB	Secondary code ^{(1) (3)}

(1) Order catalog number 440T-MDALE10AAAB to get a Dual key Access Lock with an AA primary code and an AB secondary code, with an AB key included.
 (2) Key not included.
 (3) Key included.

Table 128 - Order Example 2

440T - M KEXE 16 AA AB AC AC AC
 a b c d e f g h i

a		b		c		d		e		f		g	
Code	Description	Code	Description	Code	Description	Code	Description	Code	Description	Code	Description	Code	Description
440T	Bulletin number	A	Accessory	KEXE	Dual-key access lock	16	Product feature	AA	Primary code (1)(2)	AB	Primary code (1)(2)	AC	Secondary code (1)(3)
		M	Machine interlock										

h		i	
Code	Description	Code	Description
AC	Secondary code (1)(3)	AC	Secondary code (1)(3)

- (1) Order catalog number 440T-MKEXE16AAABACACAC to get a key exchange unit with AA and AB primary codes and three AC secondary codes. The AA and AB keys are not included. The three AC keys, which are trapped in the secondary code barrels, are included.
- (2) Key not included.
- (3) Key included.

Key Coding

Key codes are available in single, double, and triple letters. Available key codes are A...z, Aa...Zz, Aaa...Eac (first letter A...E; second letter a...f; third letter a...z). There are only 25 letters used - Q is not used.

Examples of key codes in a catalog string:
 440T-MRPSE110A = key code A
 440T-MRPSE11AA = key code Aa
 440T-MRPSE113AAA = key code Aaa

	Code	Application & Date	Code	Application & Date	Code	Appli & Da
Start Down		granulator machine #472 24/3/01 ime 67	Aa		Ab	
			Ba		Bb	
			Ca		Cb	
			Da		Db	

Table 129 is an example reference guide that is useful to select and track codes. Single letter codes are ordered with upper case letters. Labels with two or three letter codes have the first letter upper case and the remaining letters lower case.

Table 129 - Code Selection and Tracking

Code	Application Date	Code	Application Date	Code	Application Date	Code	Application Date	Code	Application Date	Code	Application Date
Aa		Ab		Ac		Ad		Ae		Af	
Ba		Bb		Bc		Bd		Be		Bf	
Ca		Cb		Cc		Cd		Ce		Cf	
Da		Db		Dc		Dd		De		Df	
Ea		Eb		Ec		Ed		Ee		Ef	
Fa		Fb		Fc		Fd		Fe		Ff	
Ga		Gb		Gc		Gd		Ge		Gf	
Ha		Hb		Hc		Hd		He		Hf	
Ia		Ib		Ic		Id		Ie		If	
Ja		Jb		Jc		Jd		Je		Jf	
Ka		Kb		Kc		Kd		Ke		Kf	
La		Lb		Lc		Ld		Le		Lf	
Ma		Mb		Mc		Md		Me		Mf	
Na		Nb		Nc		Nd		Ne		Nf	
Oa		Ob		Oc		Od		Oe		Of	
Pa		Pb		Pc		Pd		Pe		Pf	
Qa ⁽¹⁾		Qb ⁽¹⁾		Qc ⁽¹⁾		Qd ⁽¹⁾		Qe ⁽¹⁾		Qf ⁽¹⁾	
Ra		Rb		Rc		Rd		Re		Rf	
Sa		Sb		Sc		Sd		Se		Sf	
Ta		Tb		Tc		Td		Te		Tf	
Ua		Ub		Uc		Ud		Ue		Uf	
Va		Vb		Vc		Vd		Ve		Vf	
Wa		Wb		Wc		Wd		We		Wf	
Xa		Xb		Xc		Xd		Xe		Xf	
Ya		Yb		Yc		Yd		Ye		Yf	
Za		Zb		Zc		Zd		Ze		Zf	

(1) Key Code Q only available as Engineered to Order.

Rotary Switches

The rotary trapped key interlock switches have the following features:

- 316L stainless-steel keys
- Direct-drive operation – positively opens contacts
- Stainless-steel dust cap included
- Up to 100 A isolation
- 4 N.O., 2 N.O. and 2 N.C., 3 N.O./1 N.C., 3 N.O., or 3 N.C. and neutral contacts
- Replaceable code barrel assembly



Specifications

Table 130 – Rotary Switch Specifications

Attribute	Value				
Standards Classification (Safety)	EN ISO 14119 and GS-ET-31, and can be used in safety application up to category 3, PLd in accordance with EN ISO 13849-1, and in the application area of EN 60204-1.				
Functional Safety Data	PFHD = 1.00E-7 (probability of dangerous failure per hr); T1 = 20 (Proof test interval)				
Certifications	CE Marked for all applicable directives, UKCA Marked for all applicable regulations, and TÜV Certified rok.auto/certifications				
Conduit entry	4 x M20 (RKS only)				
Operating temperature	-10...+40 °C (14...104 °F) Enclosed: -25...+40 °C (-13...+104 °F)				
Mechanical life	200,000 operations				
Shear force to key, max	15.1 kN (3394.62 lbf)				
Torque to key, max	14 N•m (10.33 lb•ft)				
Relative humidity	95%				
Finger protection	DIN 57106/VDE 0106 T.100				
Weight	RPSE	10, 11, 12, 13, 20: 500 g (1.1 lb)	14, 16: 1000 g (2.2 lb)		
	RKSE	10, 11, 12, 13: 850 g (1.9 lb)	14: 1250 g (2.8 lb)		
Climatic test	<ul style="list-style-type: none"> • Constant to DIN IEC 68 Part 2-3 • Variable to DIN IEC 68 Part 2-30 				
Rated insulation voltage (Ui)	690V				
Rated impulse withstand voltage (Uimp)	6 kV				
S3 intermittent rating duty factor (VDE 0530, Part 1)	60/40/25% = 1, 3/1, 6/2 xlu				
Last two digits of cat. no. (See Product Selection on page 101.)	10, 11, 16	12	13	14	
Rated uninterrupted current (Iu)	IEC/EN/VDE	20 A	32 A	63 A	100 A
	UL/CSA	16 A	30 A	60 A	100 A
Rated operational voltage (Ue)	EC/EN/VDE	690V	690V	690V	1000V
	UL/CSA	600V	600V	600V	600V
	Main switch isolation voltage, max	750V	750V	750V	1000V
Rated operating current (Ie)	AC-21A IEC/EN/VDE	20 A	32 A	63 A	100 A
	AC-1 SEV	20 A	32 A	63 A	100 A
Rated operational power at 50/60 Hz (AC-23A IEC/EN/VDE)	3-phase 220...240V	4 kW	7.5 kW	15 kW	22 kW
	3-pole 380...440V	7.5 kW	15 kW	30 kW	37 kW
	500...690V	7.5 kW	15 kW	30 kW	37 kW
Rated operational power at 50/60 Hz (AC-3A IEC/EN/VDE)	3-phase 220...240V	4 kW	7.5 kW	15 kW	22 kW
	3-pole 380...440V	5.5 kW	11 kW	22 kW	37 kW
	500...690V	5.5 kW	11 kW	22 kW	37 kW
DOL rating (UL/CSA)	3-phase 140V	1.5 HP	3 HP	5 HP	7.5 HP
	3-pole 240V	3 HP	10 HP	15 HP	30 HP
	480V	7.5 HP	20 HP	30 HP	50 HP
	600V	10 HP	20 HP	40 HP	50 HP
Rated breaking capacity	AC-23/AC-3 220...240V	250 A	330 A	500 A	600 A
	Motor switch 80...440V	250 A	330 A	500 A	600 A
	500...690V	150 A	220 A	270 A	600 A
Fuse rating (GI)	330 A	500 A	600 A		

Table 130 - Rotary Switch Specifications (Continued)

Attribute	Value			
Rated fuse short circuit current, max	25 A	35 A	63/50 A	100 A
Terminal cross section	1...10		4...16	2.5...3.5
	mm ² single/multiple wire			
Conductor size, mm ² (min...max)	0.75 ...6		2.5...10	1.5...2.5
	(stranded) with sleeve			
	8 AWG		6 AWG	2 AWG

Product Selection

Table 131 - Enclosure-mounted IP65 (RKS only)

Contacts	Current	Cat. No. (1)
4 N.O.	20 A	440T-MRKSE10x
2 N.O. and 2 N.C.	20 A	440T-MRKSE11x
4 N.O.	32 A	440T-MRKSE12x
4 N.O.	63 A	440T-MRKSE13x
3 N.O. and 1 N.O.	3 N.O. 100 A and 1 N.O. 20 A	440T-MRKSE14x

(1) Substitute the desired primary code for x (key not included). See [Key Coding on page 98](#) for code selection.





Table 132 - Panel Mounted

Contacts	Current	Cat. No. (1)
4 N.O.	20 A	440T-MRPSE10x
2 N.O. and 2 N.C.	20 A	440T-MRPSE11x
4 N.O.	32 A	440T-MRPSE12x
4 N.O.	63 A	440T-MRPSE13x
3 N.O. and 1 N.O.	3 N.O. 100 A and 1 N.O. 20 A	440T-MRPSE14x
8 N.O.	20 A	440T-MRPSE16x
3 N.O. and 3 N.C.	20 A	440T-MRPSE18x
4 N.O.	40 A	440T-MRPSE20x

(1) Substitute the desired primary code for x (key not included). See [Key Coding on page 98](#) for code selection.



Table 133 - Multi-key Rotary Switches

	Type	Number of Keys	Contacts	Current	Cat. No.
	Dual key isolator ⁽¹⁾	2 keys out	4 N.O.	20 A	440T-MMRSE10xx ⁽²⁾
			2 N.O. and 2 N.C.	20 A	440T-MMRSE11xx ⁽²⁾
			4 N.O.	32 A	440T-MMRSE12xx ⁽²⁾
			4 N.O.	63 A	440T-MMRSE13xx ⁽²⁾
	Triple key isolator ⁽¹⁾	3 keys out	4 N.O.	20 A	440T-MMRSE20xxx ⁽²⁾
			2 N.O. and 2 N.C.	20 A	440T-MMRSE21xxx ⁽²⁾
			4 N.O.	32 A	440T-MMRSE22xxx ⁽²⁾
			4 N.O.	63 A	440T-MMRSE23xxx ⁽²⁾
	Quad key isolator ⁽¹⁾	4 keys out	4 N.O.	20 A	440T-MMRSE30xxxx ⁽²⁾
			2 N.O. and 2 N.C.	20 A	440T-MMRSE31xxxx ⁽²⁾
			4 N.O.	32 A	440T-MMRSE32xxxx ⁽²⁾
			4 N.O.	63 A	440T-MMRSE33xxxx ⁽²⁾
	Dual key exchange isolator ⁽¹⁾	1 key in/ 1 key out	4 N.O.	20 A	440T-MMRXE10xy ^{(2) (3)}
			2 N.O. and 2 N.C.	20 A	440T-MMRXE11xy ^{(2) (3)}
			4 N.O.	32 A	440T-MMRXE12xy ^{(2) (3)}
			4 N.O.	63 A	440T-MMRXE13xy ^{(2) (3)}
	Triple key exchange isolator ⁽¹⁾	1 key in/ 2 keys out	4 N.O.	20 A	440T-MMRXE20xyy ^{(2) (3)}
			2 N.O. and 2 N.C.	20 A	440T-MMRXE21xyy ^{(2) (3)}
			4 N.O.	32 A	440T-MMRXE22xyy ^{(2) (3)}
			4 N.O.	63 A	440T-MMRXE23xyy ^{(2) (3)}
	Quad key exchange isolator ⁽¹⁾	1 key in/ 3 keys out	4 N.O.	20 A	440T-MMRXE30xyyy ^{(2) (3)}
			2 N.O. and 2 N.C.	20 A	440T-MMRXE31xyyy ^{(2) (3)}
			4 N.O.	32 A	440T-MMRXE32xyyy ^{(2) (3)}
			4 N.O.	63 A	440T-MMRXE33xyyy ^{(2) (3)}

(1) Isolator on first key out.
 (2) Substitute the desired primary code for x (key not included). See [Key Coding on page 98](#) for code selection.
 (3) Substitute the desired secondary code for y (key not included). See [Key Coding on page 98](#) for code selection.

Accessories

Table 134 - Rotary Switch Accessories

Description	Additional Information	Cat. No.
Stainless-steel key	See Accessories on page 140 .	440T-AKEYE10x ⁽¹⁾
Stainless-steel replacement code barrel for products other than 100 A RPS/RKS units		440T-ASCBE14x ⁽¹⁾
Stainless-steel replacement code barrel for 100 A unit rotary switch		440T-ASCBE11x ⁽¹⁾
Stainless-steel weatherproof replacement dust cap		440T-ASF10x ⁽¹⁾
Cable grip, M20 conduit, accommodates cable diameter 7...10.5 mm (0.27...0.41 in.)	-	440A-A09028
Adapter, conduit, M20 to 1/2 inch NPT, plastic		440A-A09042
Supplemental contact block, 20 A, 1 N.O. late make, early break 1 N.C. auxiliary	For use with RPSE12, RPSE20 (1 per switch, max)	440T-AACA10
Supplemental contact block, 20 A, 2 N.O. late make, early break	For use with RPSE12, RPSE20 (1 per switch, max)	440T-AACA11
Supplemental contact block, 20 A, 1 N.O., 1 N.C.	For use with RPSE13 and 14	440T-AACA20
Supplemental contact block, 20 A, 2 N.O.	For use with RPSE13 and 14	440T-AACA21

(1) Substitute the desired primary code for x (key not included). See [Key Coding on page 98](#) for code selection.

Approximate Dimensions

Dimensions are not intended to be used for installation purposes.

Figure 62 - MRSE10 [mm (in.)]

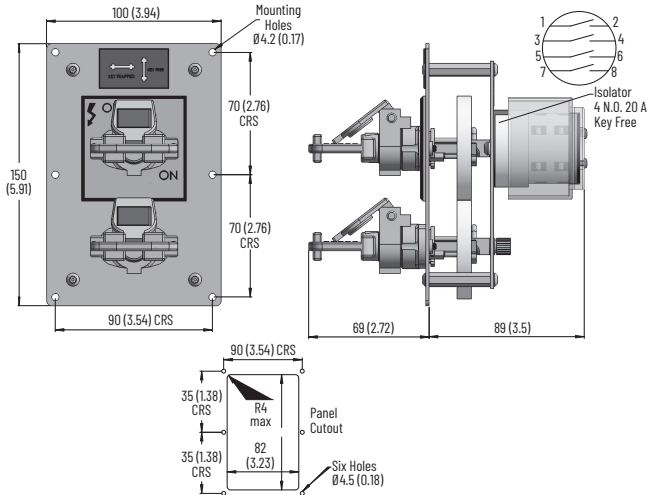

Figure 63 - MRSE20 [mm (in.)]

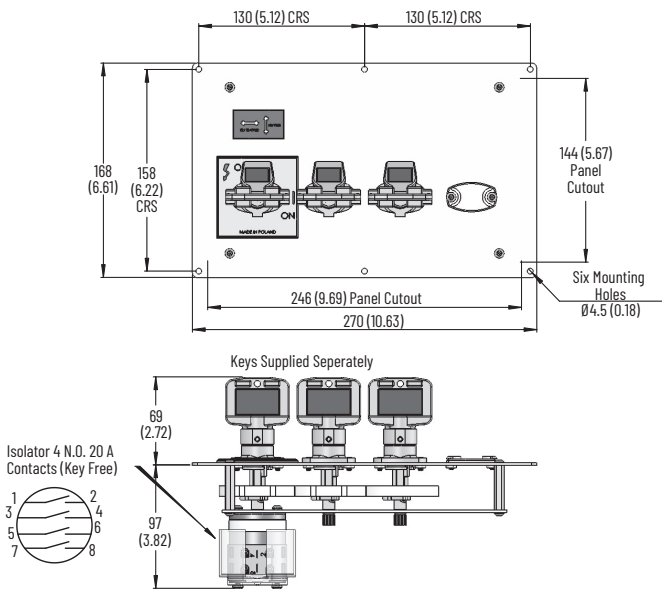

Figure 64 - MRXE10 and MRXE11 [mm (in.)]

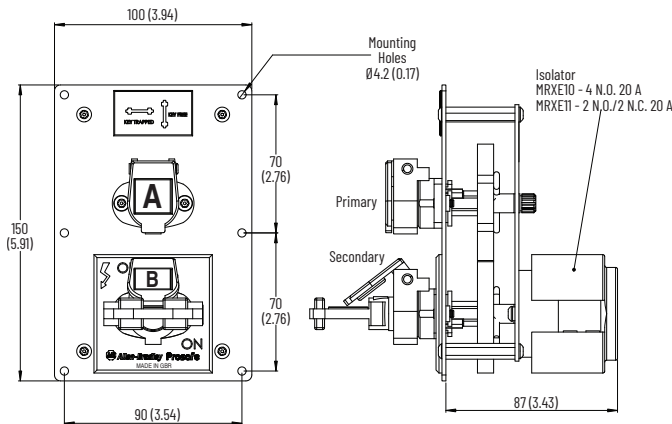

Figure 65 - MRXE30 [mm (in.)]

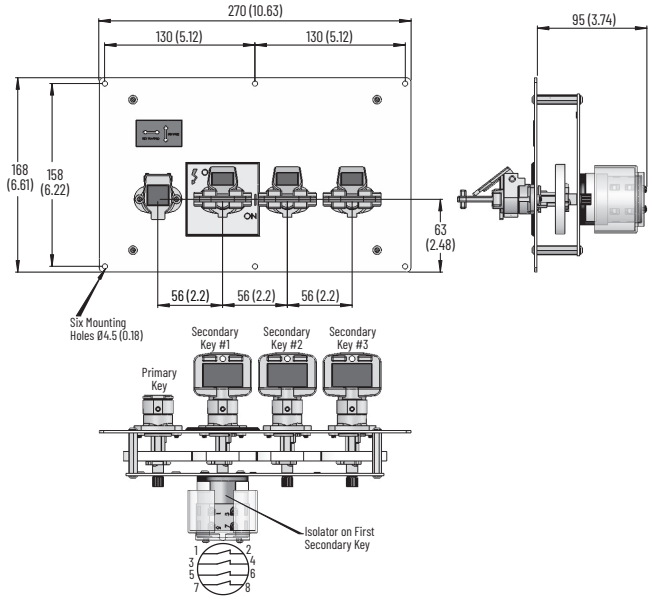

Figure 66 - RKSE10 and RKSE11 [mm (in.)]

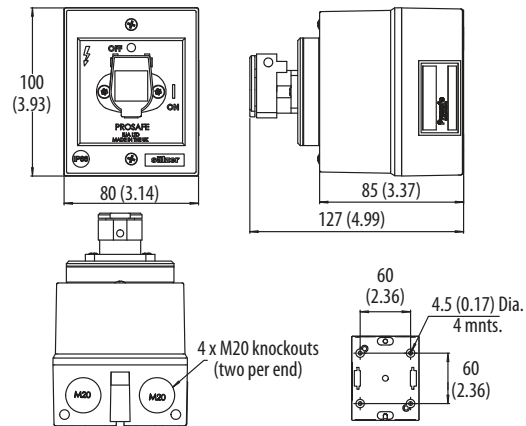

Figure 67 - RKSE12 and RKSE13 [mm (in.)]

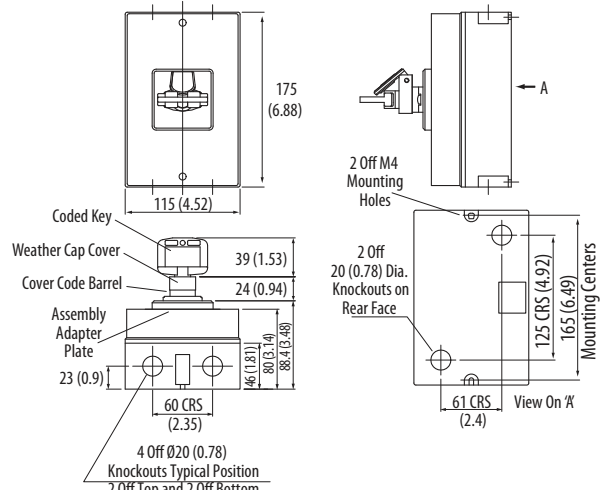

Figure 68 - RKSE14 [mm (in.)]

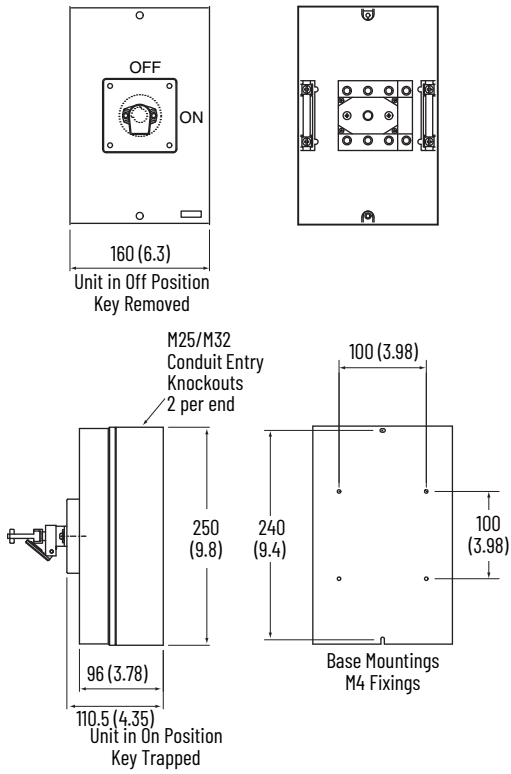

Figure 70 - RPSE12, 13, 14 and 20 [mm (in.)]

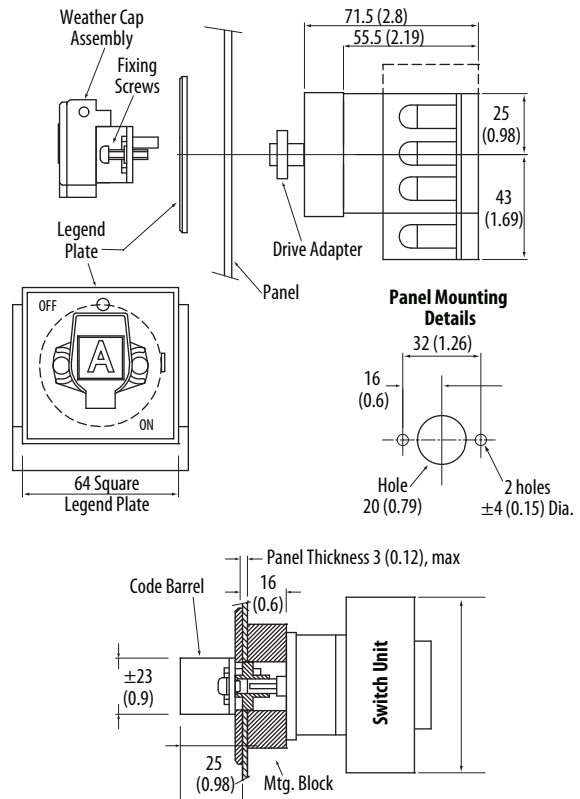

Figure 69 - RPSE10 and RPSE11 [mm (in.)]

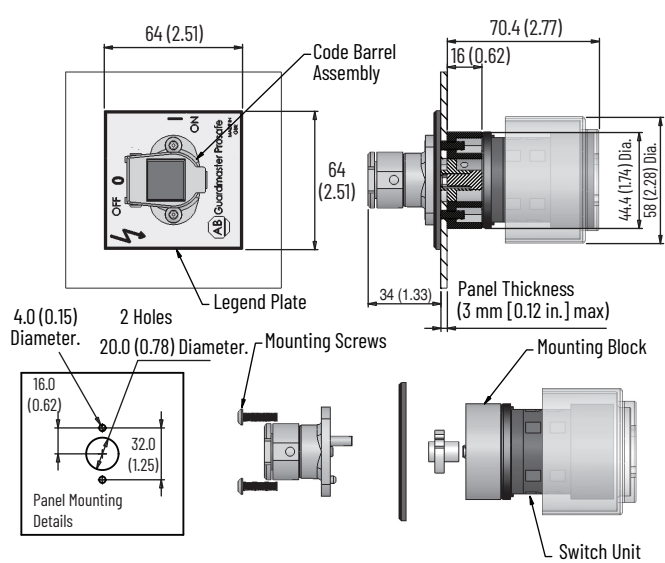

Figure 71 - RPSE16 [mm (in.)]

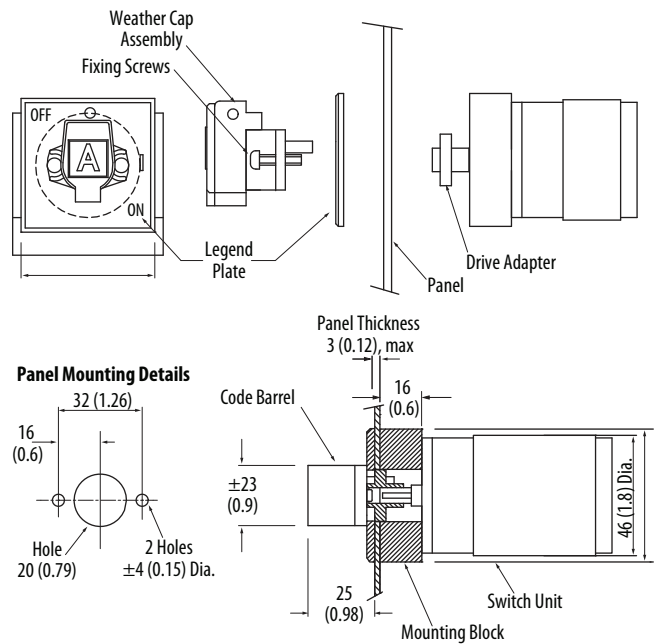
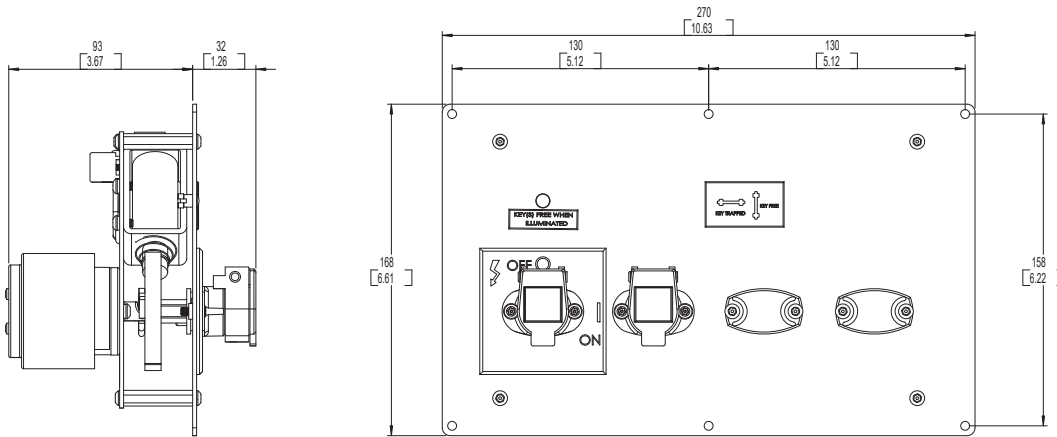

Figure 72 - Multi Key [mm (in.)]



Switch Operation

Figure 73 - Dual Key (Two Keys Out)

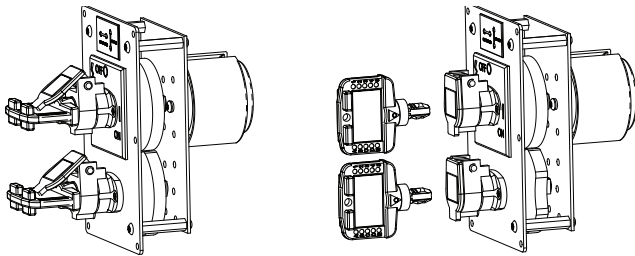

Figure 74 - Dual Key (One Key In/One Key Out)

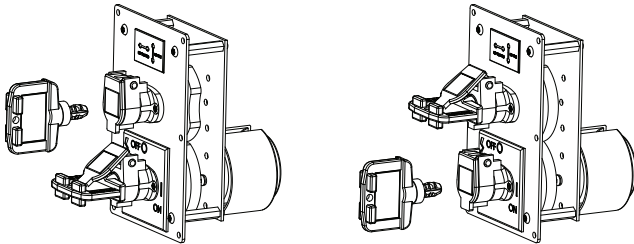

Figure 75 - Multi-key (Four Keys Out)

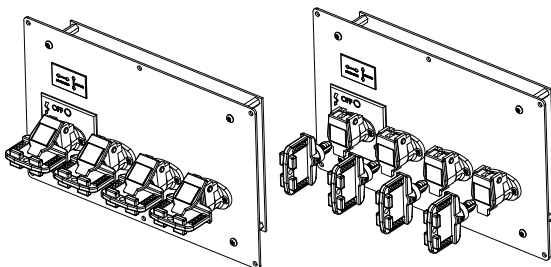
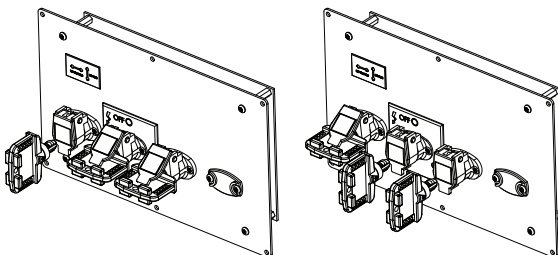
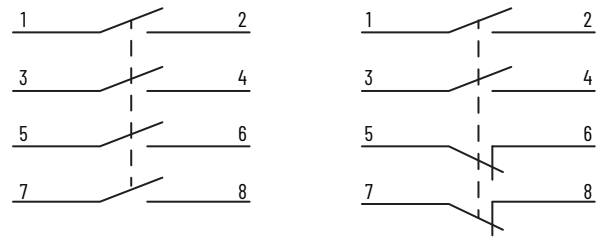

Figure 76 - Multi-key (One Key In/Two Keys Out)



Typical Wiring Diagrams

Figure 77 - Diagrams Shown with Key Free



RKSE12 and RPSE12
RKSE13 and RPSE13
RPSE20

RKSE11 and RPSE11

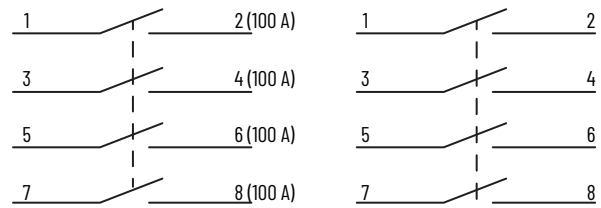

RKSE14 and RPSE14

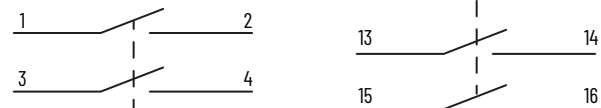

RPSE16

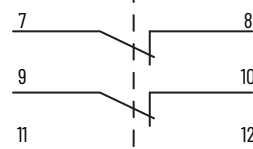

MPSE18

Solenoid Release Units

The trapped key solenoid release units have the following features:

- Direct-drive operation—positively opens contacts
- Integral solenoid monitoring
- Key trapped until release signal is applied
- Green key free status indicator
- 316L stainless-steel construction
- 24V DC, 110V DC, 110V AC, or 230V AC solenoid options
- Weatherproof stainless-steel dust cap as standard
- UL and CSA approval on switches
- Single or multiple key units available (contact factory)
- Replaceable code barrel assembly



Specifications

Table 135 - Solenoid Release Unit Specifications

Attribute	Value
Standards Classification (Safety)	EN ISO 14119 and GS-ET-31, and can be used in safety application up to category 3, PLd in accordance with EN ISO 13849-1, and in the application area of EN 60204-1.
Functional Safety Data	PFHD = 1.00E-7 (probability of dangerous failure per hr); T1 = 20 (Proof test interval)
Certifications	CE Marked for all applicable directive, UKCA Marked for all applicable regulations, and TÜV Certified rok.auto/certifications
Solenoid rating	24V DC (11 W), 110V DC (11 W), 110V AC (17VA), and 230V AC (17VA)
Solenoid power	<ul style="list-style-type: none"> • DC Types: 6.5 W continuous • AC Types: 6V A continuous
Electrical characteristics	See Specifications on page 100 .
Mounting	Any position
Shear force to key, max	15.1 kN (3394.62 lbf)
Torque to key, max	14 N•m (10.33 lb•ft)
Cable type	0.75 mm ² (18 AWG) 2-wire PVC jacket OD
Operating temperature	0...40° C (32...104° F)
Relative humidity	95%
Material	<ul style="list-style-type: none"> • Trapped key components: 316L stainless steel • Faceplate: 316L stainless steel • Optional box: ABS plastic or stainless steel
Mechanical life	200,000 operations

Product Selection

Table 136 - Solenoid Release Unit Product Selection

Type	Solenoid Voltage	Contacts	Current	Cat. No.		
Single Key Out	24V DC	2 N.O. and 2 N.C.	20 A	440T-MSRUE11x ⁽¹⁾		
		4 N.O.		440T-MSRUE10x ⁽¹⁾		
	110V AC	2 N.O. and 2 N.C.	20 A	440T-MSRUE12x ⁽¹⁾		
		4 N.O.		440T-MSRUE22x ⁽¹⁾		
	230V AC	2 N.O. and 2 N.C.	20 A	440T-MSRUE20x ⁽¹⁾		
		4 N.O.		440T-MSRUE23x ⁽¹⁾		
	110V DC	2 N.O. and 2 N.C.	20 A	440T-MSRUE33x ⁽¹⁾		
		4 N.O.		440T-MSRUE30x ⁽¹⁾		
	Dual Key Out	24V DC	2 N.O. and 2 N.C.	20 A	440T-MSRUE34x ⁽¹⁾	
			4 N.O.		440T-MSRUE44x ⁽¹⁾	
			4 N.O.	20 A	440T-MSRUE40x ⁽¹⁾	
			3 N.O. and 3N.C.		440T-MSRUE46x ⁽¹⁾	
110V AC			2 N.O. and 2 N.C.	20 A	440T-MSRUE44x ⁽¹⁾	
			4 N.O.		440T-MSRUE40x ⁽¹⁾	
Triple Key Out		24V DC	4 N.O.	20 A	440T-MS2097Dxx ⁽¹⁾	
			2 N.O. and 2 N.C.		440T-MS2097Axx ⁽¹⁾	
			4 N.O.	32 A	440T-MS2097Gxx ⁽¹⁾	
			4 N.O.		440T-MS2097Jxx ⁽¹⁾	
			110V AC	4 N.O.	20 A	440T-MS2097Dxxx ⁽¹⁾
				2 N.O. and 2 N.C.		440T-MS2097Axxx ⁽¹⁾
Quad Key Out	24V DC	4 N.O.	32 A	440T-MS3417Gxxx ⁽¹⁾		
		4 N.O.		440T-MS3417Jxxx ⁽¹⁾		
		2 N.O. and 2 N.C.	20 A	440T-MS3418Dxxxx ⁽¹⁾		
		4 N.O.		440T-MS3418Axxxx ⁽¹⁾		
		110V AC	2 N.O. and 2 N.C.	20 A	440T-MS3418Gxxxx ⁽¹⁾	
			4 N.O.		440T-MS3418Jxxxx ⁽¹⁾	

(1) Substitute the desired primary code for x (key not included). See [Key Coding on page 98](#) for code selection.

Accessories

Table 137 - Solenoid Release Unit Accessories

Description	Additional Information	Cat. No.
Stainless-steel key	See Accessories on page 140 .	440T-AKEYE10x ⁽¹⁾
Stainless-steel replacement code barrel for products other than 100 A RPS/RKS units		440T-ASCBE14x ⁽¹⁾
Stainless-steel weatherproof replacement dust cap		440T-ASF10x ⁽¹⁾
Optional IP65 plastic enclosure	For use with 20 A units	440T-AIPB10
Optional IP65 plastic enclosure	For use with 32 A units	440T-AIPB22

(1) Substitute the desired primary code for x (key not included). See [Key Coding on page 98](#) for code selection.

Approximate Dimensions

Dimensions are not intended to be used for installation purposes.

Figure 78 - Single Key [mm (in.)]

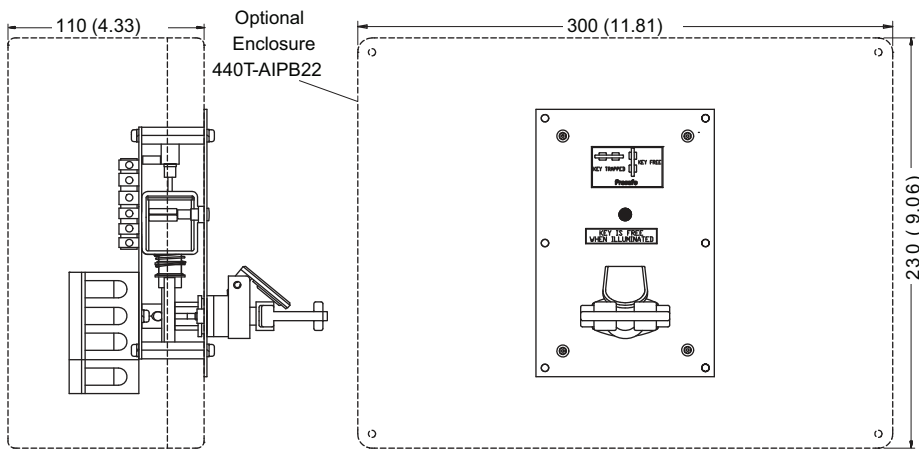
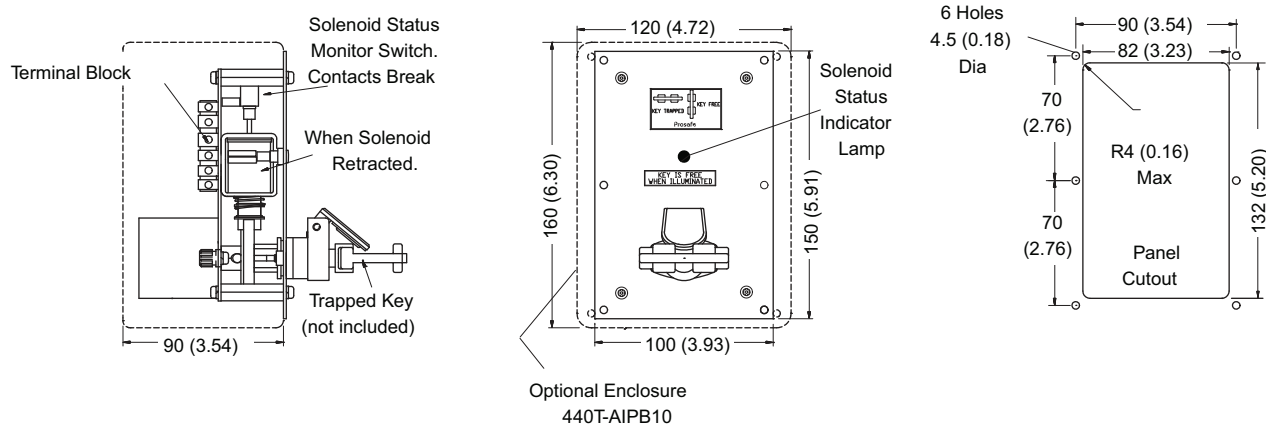
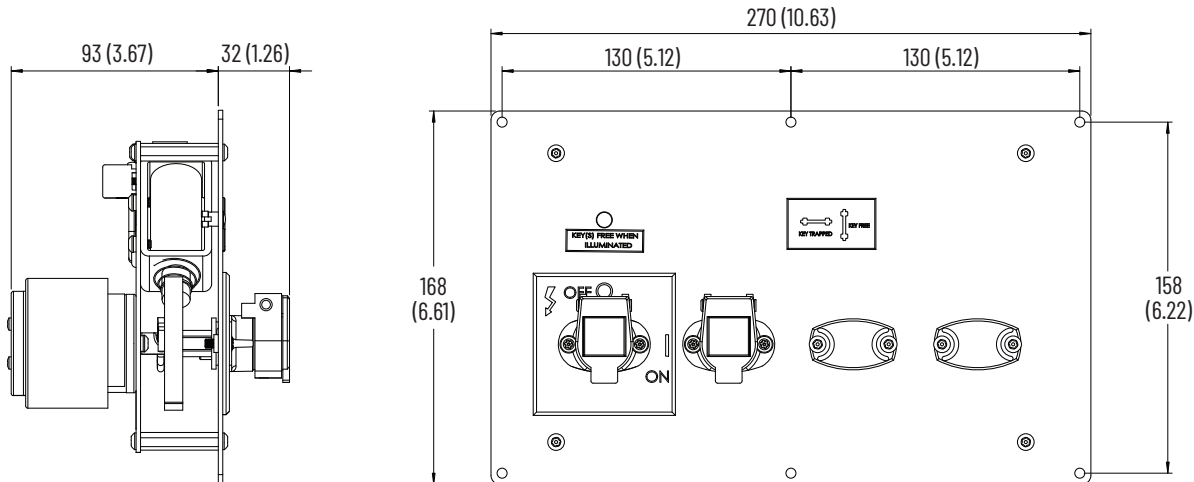

Figure 79 - Multi-key [mm (in.)]



Typical Wiring Diagrams

Figure 80 - Solenoid Release Unit Wiring

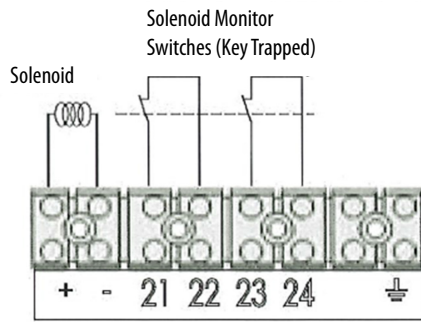
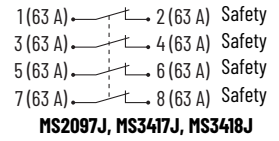
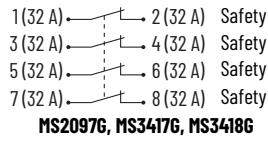
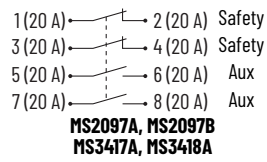
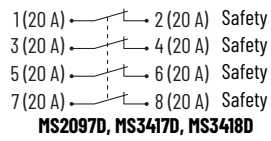

Figure 81 - Contacts



Electronic Timed-delay Units

The trapped keyswitch with electronic timed-delay units have the following features:

- Timed-delay output up to 30 minutes
- Single key or dual key
- 316L stainless-steel keys
- Category 1 Stop
- Replaceable code barrel assembly



Specifications

Table 138 - Timed-delay Unit Specifications

Attribute	Value
Standards	IEC60204-1, IEC60947-5-1
Certifications	CE Marked for all applicable directives and UKCA Marked for all applicable regulations rok.auto/certifications
Solenoid voltage	24V DC, 110V AC, 230V AC
Shear force to key, max	15.1 kN (3394.62 lbf)
Torque to key, max	14 N•m (10.33 lb•ft)
Operating temperature	0...40° C (32...104° F)
Relative humidity	95%
Material	<ul style="list-style-type: none"> • Trapped key components: 316L stainless steel • Faceplate: 316L stainless steel
Mounting	Tamper resistant screws
Mechanical life	200,000 operations
Time delay	0.1 second...30 minutes

Product Selection

Table 139 - Timed-delay Unit Product Selection

Type	Solenoid Voltage	Contact Set 1	Contact Set 2	Cat. No. (1)
Single key out panel mounted	24V DC	3 N.O. 40 A	1 N.O. 20 A	440T-MSTUE10x ⁽²⁾
		2 N.O. 20 A	1 N.O. 20 A	440T-MSTUE11x ⁽²⁾
	110V AC	3 N.O. 40 A	1 N.O. 20 A	440T-MSTUE20x ⁽²⁾
		2 N.O. 20 A	1 N.O. 20 A	440T-MSTUE22x ⁽²⁾
	230V AC	3 N.O. 40 A	1 N.O. 20 A	440T-MDTUE30x ⁽²⁾
		2 N.O. 20 A	1 N.O. 20 A	440T-MSTUE33x ⁽²⁾
Dual key out panel mounted	24V DC	3 N.O. 40 A	1 N.O. 20 A	440T-MDTUE10xx ⁽²⁾
		2 N.O. 20 A	1 N.O. 20 A	440T-MDTUE11xx ⁽²⁾
	110V AC	3 N.O. 40 A	1 N.O. 20 A	440T-MDTUE20xx ⁽²⁾
		2 N.O. 20 A	1 N.O. 20 A	440T-MDTUE22xx ⁽²⁾
	230V AC	3 N.O. 40 A	1 N.O. 20 A	440T-MDTUE30xx ⁽²⁾
		2 N.O. 20 A	1 N.O. 20 A	440T-MDTUE33xx ⁽²⁾

(1) See publication [440T-IN016](#) for safety relay connection and switch setting details.
 (2) Substitute the desired primary code for x (key not included). See [Key Coding on page 98](#) for code selection.

Accessories

Table 140 - Timed-delay Unit Accessories

Description	Additional Information	Cat. No.
Stainless-steel key	See Accessories on page 140 .	440T-AKEYE10x ⁽¹⁾
Stainless-steel replacement code barrel for products other than 100 A RPS/RKS units		440T-ASCBE14x ⁽¹⁾
Stainless-steel weatherproof replacement dust cap		440T-ASFC10x ⁽¹⁾

(1) Substitute the desired primary code for x (key not included). See [Key Coding on page 98](#) for code selection.

Typical Wiring Diagram

Figure 82 - Wiring (Shown with Power On)

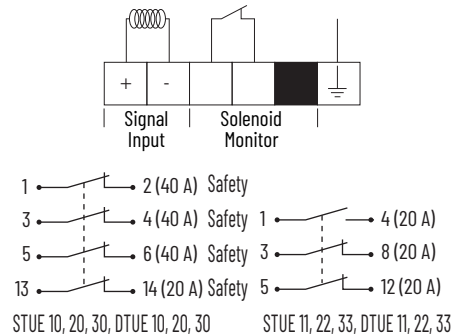

Approximate Dimensions

Dimensions are not intended to be used for installation purposes.

Figure 83 - Timed-delay Unit Dimensions [mm (in.)]

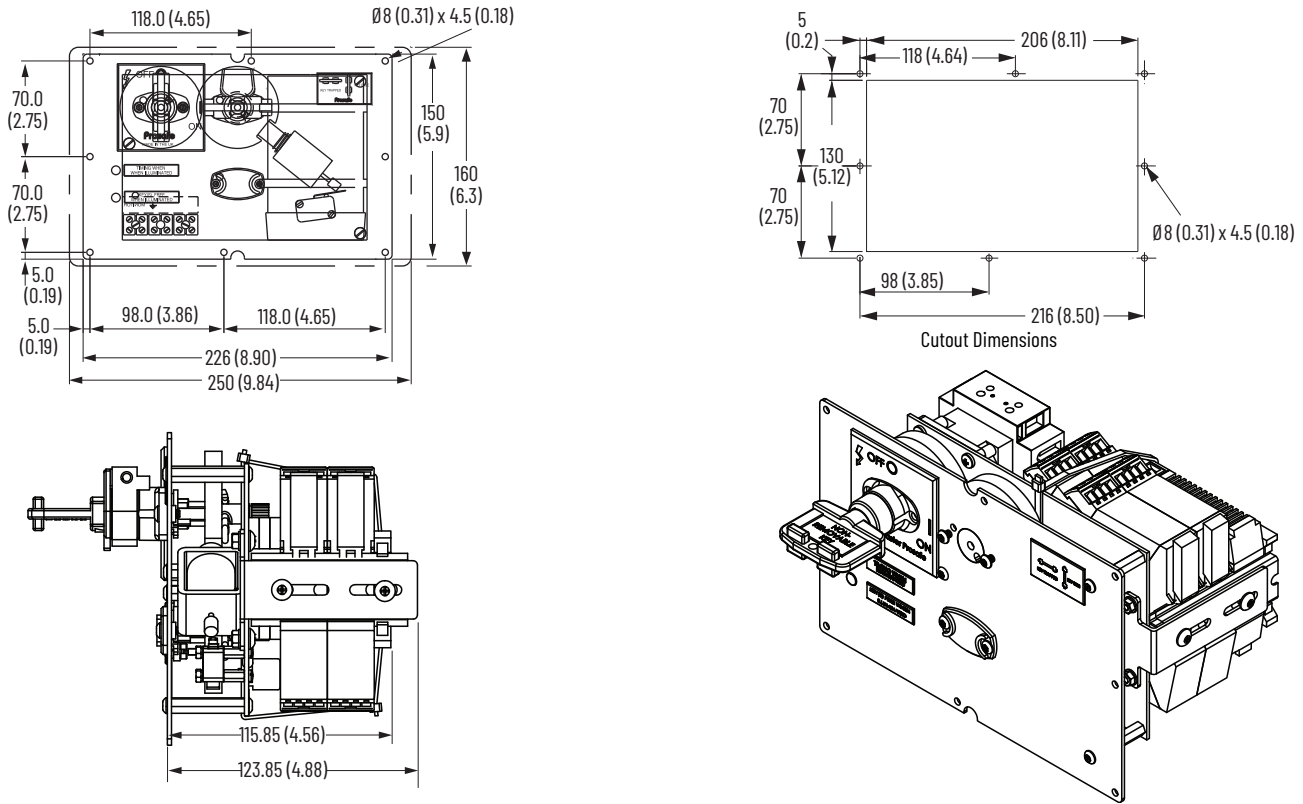

Key Exchange Units

The trapped key interlock exchange unit switches have the following features:

- A range of standard units in various combinations
- 316L stainless-steel construction
- Primary keys in release secondary keys simultaneously on units up to six ways
- Weatherproof stainless-steel dust cap as standard
- Replaceable code barrel assembly

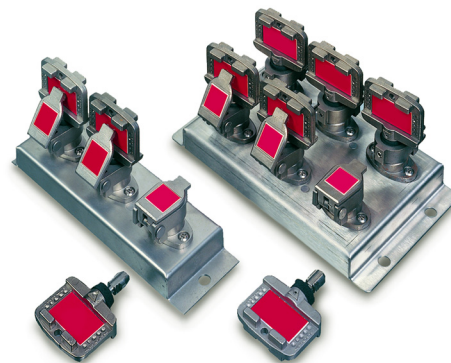

Specifications

Table 141 - Key Exchange Unit Specifications

Attribute	Value
Standards Classification (Safety)	EN ISO 14119 and GS-ET-31, and can be used in safety application up to category 3, PLd in accordance with EN ISO 13849-1, and in the application area of EN 60204-1.
Functional Safety Data	PFHD = 1.00E-7 (probability of dangerous failure per hr); T1 = 20 (Proof test interval)
Certifications	CE Marked for all applicable directives, UKCA Marked for all applicable regulations, and TÜV Certified rok.auto/certifications
Operating temperature	-40...+80 °C (-40...+176 °F)
Relative humidity	95%
Mechanical life	200,000 operations
Shear force to key, max	15.1 kN (3394.62 lbf)
Torque to key, max	14 N•m (10.33 lb•ft)
Material	316L stainless steel

Optional Key Exchange Cabinets

Table 142 - Key Exchange Cabinets

Type	Number of Keys	Length [mm (in)]	Width [mm (in)]	Depth [mm (in)]	Cat. No.
Painted mild steel	7...11 way (max)	400 (15.7)	300 (11.8)	200 (7.87)	440T-AIPB30
	12...15 way (max)	400 (15.7)	400 (15.7)	210 (8.26)	440T-AIPB33
	16...25 way (max)	600 (23.6)	600 (23.6)	210 (8.26)	440T-AIPB34
Stainless steel	12...15 way (max)	400 (15.7)	400 (15.7)	210 (8.26)	440T-AIPB40
	16...25 way (max)	600 (23.6)	600 (23.6)	210 (8.26)	440T-AIPB44

Product Selection

Table 143 - Key Exchange Unit Product Selection

Number of Keys	Keys In and Out	Cat. No.
2 way	1 key in 1 key out	440T-MKEXE10 ⁽¹⁾
3 way	1 key in 2 key out	440T-MKEXE11 ⁽¹⁾
4 way	1 key in 3 key out	440T-MKEXE12 ⁽¹⁾
5 way	1 key in 4 key out	440T-MKEXE13 ⁽¹⁾
6 way	1 key in 5 key out	440T-MKEXE14 ⁽¹⁾
4 way	2 key in 2 key out	440T-MKEXE15 ⁽¹⁾
5 way	2 key in 3 key out	440T-MKEXE16 ⁽¹⁾
6 way	2 key in 4 key out	440T-MKEXE17 ⁽¹⁾
6 way	3 key in 3 key out	440T-MKEXE18 ⁽¹⁾
7 way	1 key in 6 key out	440T-MKEXE19 ⁽¹⁾
8 way	1 key in 7 key out	440T-MKEXE20 ⁽¹⁾
9 way	1 key in 8 key out	440T-MKEXE22 ⁽¹⁾
10 way	1 key in 9 key out	440T-MKEXE23 ⁽¹⁾
11 way	1 key in 10 key out	440T-MKEXE24 ⁽¹⁾
12 way	1 key in 11 key out	440T-MKEXE25 ⁽¹⁾
13 way	1 key in 12 key out	440T-MKEXE26 ⁽¹⁾
14 way	1 key in 13 key out	440T-MKEXE27 ⁽¹⁾
15 way	1 key in 14 key out	440T-MKEXE28 ⁽¹⁾
16 way	1 key in 15 key out	440T-MKEXE29 ⁽¹⁾
17 way	1 key in 16 key out	440T-MKEXE30 ⁽¹⁾
18 way	1 key in 17 key out	440T-MKEXE33 ⁽¹⁾
19 way	1 key in 18 key out	440T-MKEXE34 ⁽¹⁾
20 way	1 key in 19 key out	440T-MKEXE35 ⁽¹⁾
21 way	1 key in 20 key out	440T-MKEXE36 ⁽¹⁾
22 way	1 key in 21 key out	440T-MKEXE37 ⁽¹⁾
23 way	1 key in 22 key out	440T-MKEXE38 ⁽¹⁾
24 way	1 key in 23 key out	440T-MKEXE39 ⁽¹⁾
25 way	1 key in 24 key out	440T-MKEXE40 ⁽¹⁾

(1) Specify the codes individually for each primary key-in (key not included) and for each secondary key (key included). See [Key Coding on page 98](#) for code selection.

Accessories

Table 144 - Key Exchange Unit Accessories

Description	Additional Information	Cat. No.
Stainless-steel key	See Accessories on page 140 .	440T-AKEYE10x ⁽¹⁾
Stainless-steel replacement code barrel for products other than 100 A RPS/RKS units		440T-ASCBE14x ⁽¹⁾
Stainless-steel weatherproof replacement dust cap		440T-ASFC10x ⁽¹⁾

(1) Substitute the desired primary code for x (key not included). See [Key Coding on page 98](#) for code selection.

Approximate Dimensions

Dimensions are not intended to be used for installation purposes.

Figure 84 - 2- or 3-way Key Exchange Unit [mm (in.)]

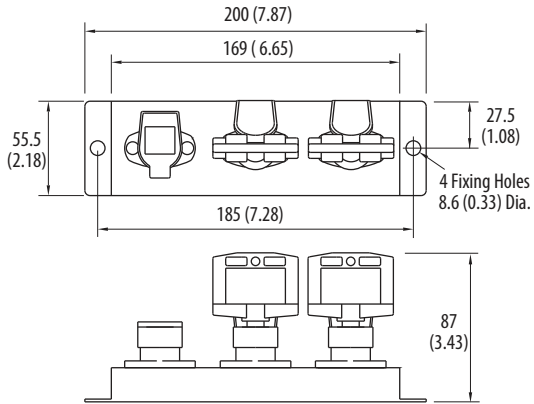

Figure 85 - 4-, 5-, or 6-way Key Exchange Unit [mm (in.)]

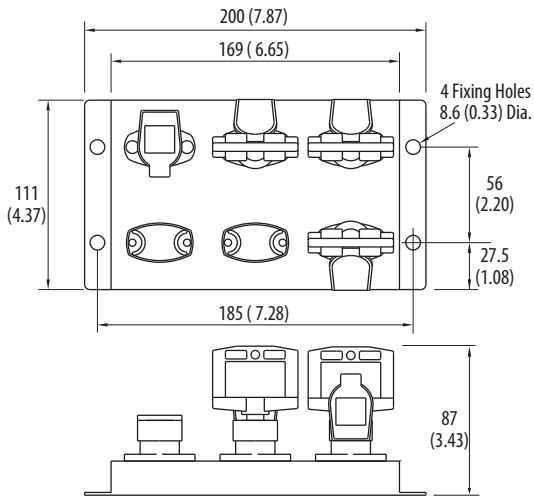

Figure 86 - 7-...11-way Units [mm (in.)]

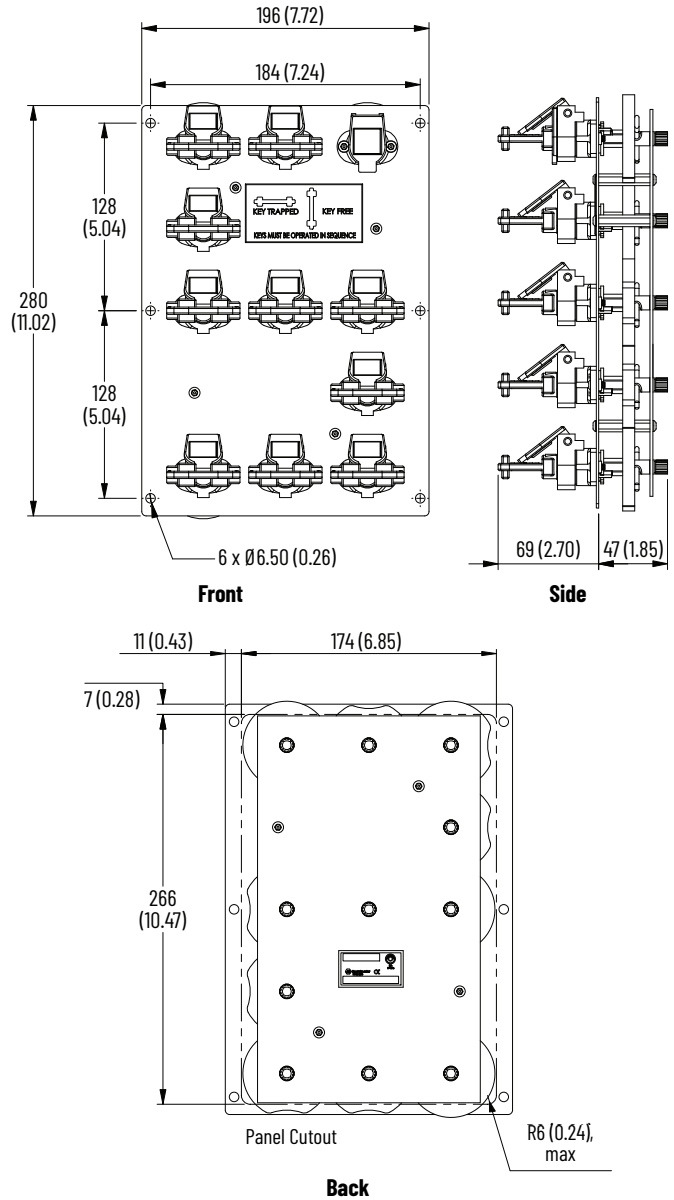

Figure 87 - 12-...15-way Units [mm (in.)]

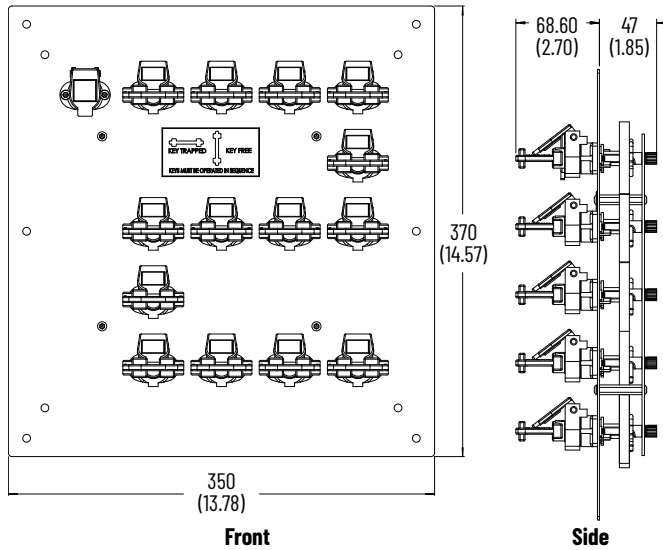

Figure 88 - 16-...25-way Units [mm (in.)]

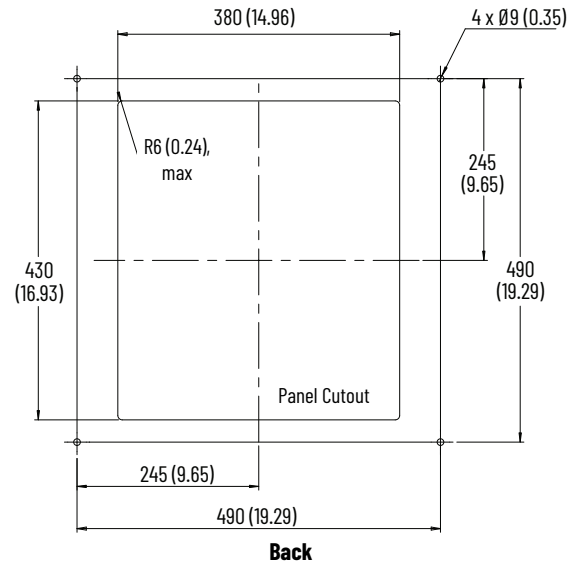
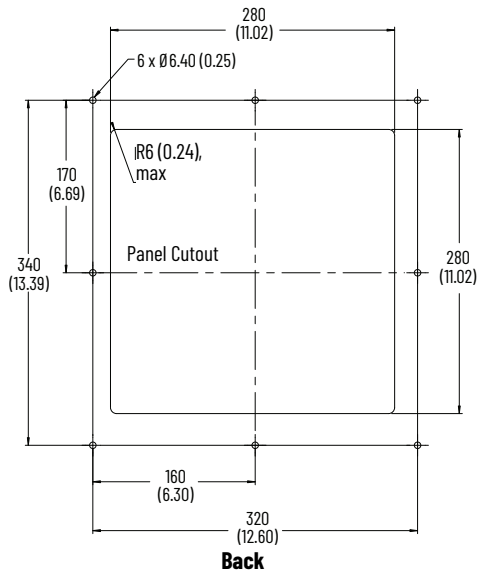
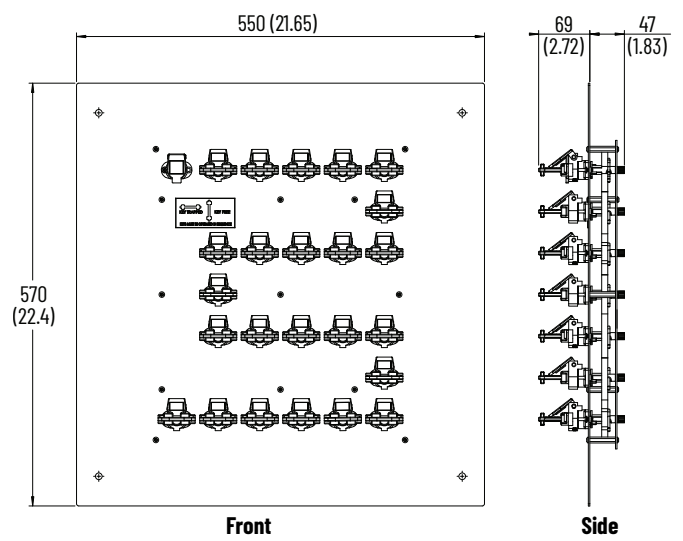
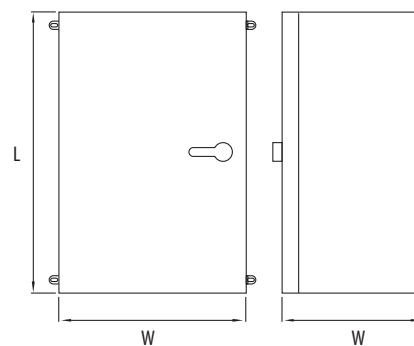

Figure 89 - Key Exchange Cabinets (Painted Mild Steel or Stainless Steel)



Bolt Interlocks

The trapped key bolt interlock switches have the following features:

- 316L stainless-steel construction
- Single or dual key units
- Various extensions of bolt
- Direct-drive push/pull operation
- Replaceable code barrel assembly
- Fitted with tamper resistant screws
- Weatherproof stainless-steel dust cap as standard

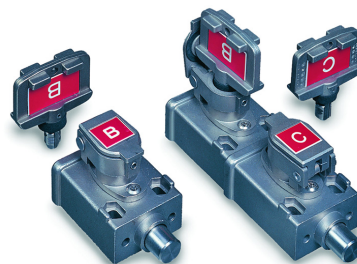

Specifications

Table 145 - Mechanical Bolt Interlock Specifications

Attribute	Value
Standards Classification (Safety)	EN ISO 14119 and GS-ET-31, and can be used in safety application up to category 3, PLd in accordance with EN ISO 13849-1, and in the application area of EN 60204-1.
Functional Safety Data	PFHD = 1.00E-7 (probability of dangerous failure per hr); T1 = 20 (Proof test interval)
Certifications	CE Marked for all applicable directives, UKCA Marked for all applicable regulations, and TÜV Certified rok.auto/certifications
Operating temperature	-40...+80 °C (-40...+176 °F)
Relative humidity	95%
Mechanical life	200,000 operations
Shear force to key, max	15.1 kN (3394.62 lbf)
Torque to key, max	14 N•m (10.33 lb•ft)
Material	Faceplate: 316L stainless steel
Mounting	SBL <ul style="list-style-type: none"> • 2 x M5 counter-bored from top • 2 x M5 from underside with M5 nuts DBL <ul style="list-style-type: none"> • 4 x M5 counter-bored from top • 4 x M5 from underside with M5 nuts
Bolt diameter	15 mm (0.59 in)

Table 146 - Electrical/Solenoid Bolt Interlock Specifications

Attribute	Value
Standards Classification (Safety)	EN ISO 14119 and GS-ET-31, and can be used in safety application up to category 3, PLd in accordance with EN ISO 13849-1, and in the application area of EN 60204-1.
Functional Safety Data	PFHD = 1.00E-7 (probability of dangerous failure per hr); T1 = 20 (Proof test interval)
Certifications	CE Marked for all applicable directives, UKCA Marked for all applicable regulations, and TÜV Certified rok.auto/certifications
Safety contacts	2 N.C. positive break
Designation/utilization category	A300/AC-15 (Ue/Ie) 240V/3 A, 120V/6 A N300/DC-13 (Ue/Ie) 250V/1.1 A, 125V/2.2 A
Thermal current	10 A
Current, min	5V 5 mA DC
Auxiliary contacts	1 N.O.
Ingress protection rating	IP67
Shear force to key, max	15.1 kN (3394.62 lbf)
Torque to key, max	14 N•m (10.33 lb•ft)
Operating temperature	-40...+80 °C (-40...+176 °F)
Mechanical life	200,000 operations
Electrical life	Dependent on load
Torque settings, max	<ul style="list-style-type: none"> • Lid screws: 0.55 N•m (4.87 lb•in) • Terminal screws: 1.0 N•m (8.85 lb•in)

Operation

Figure 90 - Single Key

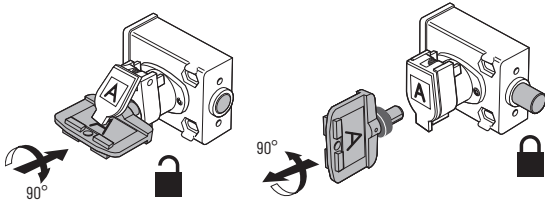

Figure 91 - Dual Key

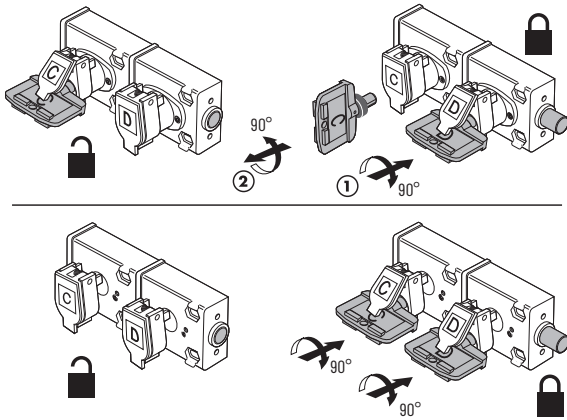

Figure 92 - Triple Key

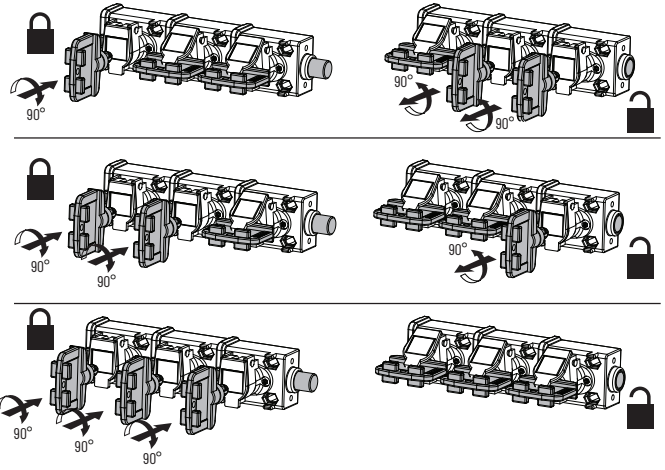
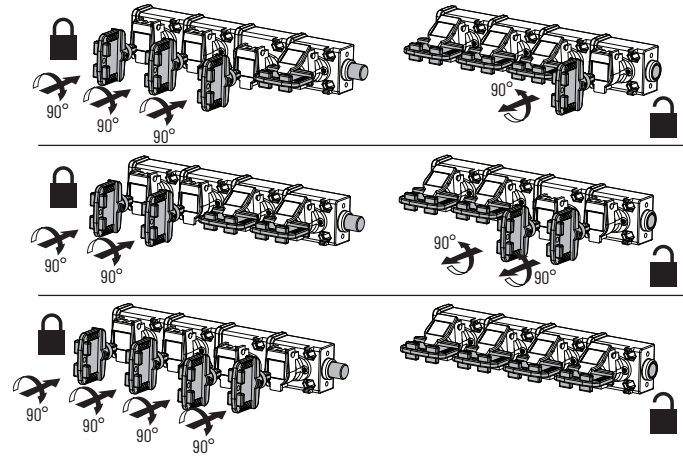

Figure 93 - Quad Key



Product Selection

Table 147 - Mechanical Bolt Interlock Product Selection

Type	Trapped Key Condition	Bolt Retracted [mm (in.)]	Bolt Extended [mm (in.)]	Cat. No.
Single key	Bolt projected (guard is secured) Primary key 1 is free (ordered separately) Insert primary key 1 and rotate 90° CW to retract bolt Primary key 1 is now trapped (guard can be accessed)	0	14 (0.55)	440T-MSBLE10x ⁽¹⁾
		3 (0.11)	17 (0.66)	440T-MSBLE11x ⁽¹⁾
		6 (0.23)	20 (0.78)	440T-MSBLE12x ⁽¹⁾
		13 (0.51)	27 (1.06)	440T-MSBLE13x ⁽¹⁾
	Bolt projected (guard is secured) Primary key 1 is free (ordered separately) Insert primary key 1 and rotate 90° CW to extend bolt Primary key 1 is now trapped (guard is secure)	0	14 (0.55)	440T-MSBLE33x ⁽¹⁾
		3 (0.11)	17 (0.66)	440T-MSBLE34x ⁽¹⁾
		6 (0.23)	20 (0.78)	440T-MSBLE35x ⁽¹⁾
		13 (0.51)	27 (1.06)	440T-MSBLE36x ⁽¹⁾
Dual key	Bolt projected (guard is secured) Primary keys are free (ordered separately) Insert primary key 1 into the lock, then insert primary key 2 Rotate both keys 90° CW to retract bolt Primary keys are now trapped (guard can be accessed)	0	14 (0.55)	440T-MDBLE10x ⁽¹⁾
		3 (0.11)	17 (0.66)	440T-MDBLE11x ⁽¹⁾
		6 (0.23)	20 (0.78)	440T-MDBLE12x ⁽¹⁾
		13 (0.51)	27 (1.06)	440T-MDBLE13x ⁽¹⁾
	Bolt projected (guard is secured) Primary key 1 free (ordered separately), secondary key 1 trapped Insert primary key 1 and rotate 90° CW Rotate secondary key 90° CCW to retract bolt Primary key 1 is now trapped (guard can be accessed) Secondary key 1 is free (personal key)	0	14 (0.55)	440T-MDBLE14xy ⁽¹⁾⁽²⁾
		3 (0.11)	17 (0.66)	440T-MDBLE15xy ⁽¹⁾⁽²⁾
		6 (0.23)	20 (0.78)	440T-MDBLE16xy ⁽¹⁾⁽²⁾
		13 (0.51)	27 (1.06)	440T-MDBLE17xy ⁽¹⁾⁽²⁾
	Bolt projected (guard is secured) Primary key 1 free (ordered separately), secondary key 1 trapped Insert primary key 1 and rotate 90° CW Rotate secondary key 1 to 90° CCW to retract bolt Primary key 1 is now trapped (guard can be accessed) Secondary key 1 ejects free from the lock (personal key)	0	14 (0.55)	440T-MDBLJ14xy ⁽¹⁾⁽²⁾
		3 (0.11)	17 (0.66)	440T-MDBLJ15xy ⁽¹⁾⁽²⁾
		6 (0.23)	20 (0.78)	440T-MDBLJ16xy ⁽¹⁾⁽²⁾
		13 (0.51)	20 (0.78)	440T-MDBLJ17xy ⁽¹⁾⁽²⁾
Triple key	Bolt projected (guard is secured) Primary keys are free (ordered separately) Insert primary key 1 into the lock, then key 2, then key 3 Rotate the 3 primary keys 90° CW to retract the bolt Primary keys are now trapped (guard can be accessed)	0	14 (0.55)	440T-MTBLE10xxx ⁽¹⁾
		3 (0.11)	17 (0.66)	440T-MDBLE11xxx ⁽¹⁾
		6 (0.23)	20 (0.78)	440T-MTBLE12xxx ⁽¹⁾
		13 (0.51)	27 (1.06)	440T-MTBLE13xxx ⁽¹⁾
	Bolt projected (guard is secured) Primary key 1 and primary key 2 are free (ordered separately) Secondary key 1 is trapped Insert primary key 1 into the lock, then key 2 Rotate primary key 1 and key 2 to 90° CW Rotate secondary key 1 to 90° CCW to retract bolt Primary key 1 and key 2 are now trapped (guard can be accessed) Secondary key 1 is free (personal key)	0	14 (0.55)	440T-MTBLE14xxy ⁽¹⁾⁽²⁾
		3 (0.11)	17 (0.66)	440T-MTBLE15xxy ⁽¹⁾⁽²⁾
		6 (0.23)	20 (0.78)	440T-MTBLE16xxy ⁽¹⁾⁽²⁾
		13 (0.51)	27 (1.06)	440T-MTBLE17xxy ⁽¹⁾⁽²⁾
	Bolt projected (guard is secured) Primary key 1 is free (ordered separately) Secondary key 1 and key 2 are trapped Insert primary key 1 into the lock and rotate 90° CW Rotate secondary key 1 and key 2 to 90° CCW to retract bolt Primary key 1 is now trapped (guard can be accessed) Secondary key 1 and key 2 are free (personal keys)	0	14 (0.55)	440T-MTBLE18xyy ⁽¹⁾⁽²⁾
		3 (0.11)	17 (0.66)	440T-MTBLE19xyy ⁽¹⁾⁽²⁾
		6 (0.23)	20 (0.78)	440T-MTBLE20xyy ⁽¹⁾⁽²⁾
		13 (0.51)	27 (1.06)	440T-MTBLE21xyy ⁽¹⁾⁽²⁾

Table 147 - Mechanical Bolt Interlock Product Selection (Continued)

Type	Trapped Key Condition	Bolt Retracted [mm (in.)]	Bolt Extended [mm (in.)]	Cat. No.
Quad key	Bolt projected (guard is secured) Primary keys are free (ordered separately) Insert primary key 1 into lock, then key 2, then key 3, then key 4 Rotate the 4 primary keys 90° CW to retract the bolt Primary keys are now trapped (guard can be accessed)	0	14 (0.55)	440T-MQBLE10xxxx ⁽¹⁾
		3 (0.11)	17 (0.66)	440T-MQBLE11xxxx ⁽¹⁾
		6 (0.23)	20 (0.78)	440T-MQBLE12xxxx ⁽¹⁾
		13 (0.51)	27 (1.06)	440T-MQBLE13xxxx ⁽¹⁾
	Bolt projected (guard is secured) Primary keys are free (ordered separately) Secondary key 1 is trapped Insert primary key 1 into the lock, then key 2, then key 3 Rotate the 3 primary keys 90° CW Rotate secondary key 1 to 90° CCW to retract the bolt Primary keys are now trapped (guard can be accessed) Secondary key 1 is free (personal key)	0	14 (0.55)	440T-MQBLE14xxyy ⁽¹⁾⁽²⁾
		3 (0.11)	17 (0.66)	440T-MQBLE15xxyy ⁽¹⁾⁽²⁾
		6 (0.23)	20 (0.78)	440T-MQBLE16xxyy ⁽¹⁾⁽²⁾
		13 (0.51)	27 (1.06)	440T-MQBLE17xxyy ⁽¹⁾⁽²⁾

(1) Substitute the desired primary code for x (key not included). See [Key Coding on page 98](#) for code selection.
 (2) Substitute the desired secondary code for y (key not included). See [Key Coding on page 98](#) for code selection.

Table 148 - Electrical Bolt Interlock Product Selection

Contact Type	Type	Trapped Key Condition	Bolt Retracted [mm (in.)]	Bolt Extended [mm (in.)]	Cat. No.
2 N.C. and 1 N.O. break before make	Single key	Bolt projected (guard is secured) Primary key 1 is free (ordered separately) 2 N.C. safety contacts are in the closed state 1 N.O. contact is in the open state Insert primary key 1 and rotate 90° CW to retract bolt 2 N.C. safety contacts are in the open state 1 N.O. contact in the closed state Primary key 1 is now trapped (guard can be accessed)	0	14 (0.55)	440T-MSBSE10x ⁽¹⁾
			3 (0.11)	17 (0.66)	440T-MSBSE11x ⁽¹⁾
			6 (0.23)	20 (0.78)	440T-MSBSE12x ⁽¹⁾
		13 (0.51)	27 (1.06)	440T-MSBSE13x ⁽¹⁾	
		Bolt retracted (guard can be accessed) Primary key 1 is free (ordered separately) 2 N.C. safety contacts are in the open state 1 N.O. contact is in the closed state Insert primary key 1 and rotate 90° CCW to extend bolt 2 N.C. safety contacts are in the closed state 1 N.O. contact in the open state Key 1 is now trapped (guard is secured)	0	14 (0.55)	440T-MSBSE33x ⁽¹⁾
			3 (0.11)	17 (0.66)	440T-MSBSE34x ⁽¹⁾
	6 (0.23)		20 (0.78)	440T-MSBSE35x ⁽¹⁾	
	Dual key	Bolt projected (guard is secured) Primary keys are free (ordered separately) 2 N.C. safety contacts are in the closed state 1 N.O. contact is in the open state Insert primary key 1 into the lock then insert primary key 2 Rotate both keys, 90° CW to retract bolt 2 N.C. safety contacts are in the open state 1 N.O. contact in the closed state Primary keys are now trapped (guard can be accessed)	0	14 (0.55)	440T-MDBSE10xx ⁽¹⁾
			3 (0.11)	17 (0.66)	440T-MDBSE11xx ⁽¹⁾
			6 (0.23)	20 (0.78)	440T-MDBSE12xx ⁽¹⁾
		13 (0.51)	27 (1.06)	440T-MDBSE13xx ⁽¹⁾	
		Bolt projected (guard is secured) Primary keys are free (ordered separately) Secondary key 1 is trapped 2 N.C. safety contacts are in the closed state 1 N.O. contact is in the open state Insert primary key 1 and rotate 90° CW Primary key 1 is now trapped Rotate secondary key 1 to 90° CCW to retract bolt 2 N.C. safety contacts are in the open state 1 N.O. contact in the closed state Secondary key is free (personal key) (guard can be accessed)	0	14 (0.55)	440T-MDBSE14xy ⁽¹⁾⁽²⁾
3 (0.11)			17 (0.66)	440T-MDBSE15xy ⁽¹⁾⁽²⁾	
6 (0.23)	20 (0.78)		440T-MDBSE16xy ⁽¹⁾⁽²⁾		
13 (0.51)	27 (1.06)	440T-MDBSE17xy ⁽¹⁾⁽²⁾			

(1) Substitute the desired primary code for x (key not included). See [Key Coding on page 98](#) for code selection.
 (2) Substitute the desired secondary code for y (key not included). See [Key Coding on page 98](#) for code selection.

Table 149 - Solenoid Bolt Interlock Product Selection

Solenoid Voltage	Contact Type	Type	Trapped Key Condition	Bolt Retracted [mm (in.)]	Bolt Extended [mm (in.)]	Cat. No.	
24V DC	2 N.C. and 1 N.O. break before make	Single key	Bolt projected (guard is secure) Primary key 1 is trapped 2 N.C. safety contacts are in the closed state 1 N.O. contact is in the open state Apply 24V DC to the solenoid Insert primary key 1 and rotate 90° CW to retract bolt 2 N.C. safety contacts are in the open state 1 N.O. contact in the closed state Primary key 1 is free (personal key) (guard can be accessed)	0	14 (0.55)	440T-MSBUE10x ⁽¹⁾	
				3 (0.11)	17 (0.66)	440T-MSBUE11x ⁽¹⁾	
				6 (0.23)	20 (0.78)	440T-MSBUE12x ⁽¹⁾	
				13 (0.51)	27 (1.06)	440T-MSBUE13x ⁽¹⁾	
				0	14 (0.55)	440T-MSBUE33x ⁽¹⁾	
				3 (0.11)	17 (0.66)	440T-MSBUE34x ⁽¹⁾	
			Dual key	Bolt retracted (guard can be accessed) Primary key 1 is trapped 2 N.C. safety contacts are in the open state 1 N.O. contact is in the closed state Apply 24V DC to the solenoid Rotate primary key 1 to 90° CCW to extend bolt 2 N.C. safety contacts are in the closed state 1 N.O. contact in the open state Primary key 1 is free (personal key) (guard is secured)	6 (0.23)	20 (0.78)	440T-MSBUE35x ⁽¹⁾
				13 (0.51)	27 (1.06)	440T-MSBUE36x ⁽¹⁾	
				Bolt projected (guard is secure) Primary keys are free (ordered separately) 2 N.C. safety contacts are in the closed state 1 N.O. contact is in the open state Insert primary key 1 into the lock, then insert primary key 2 Apply 24V DC to the solenoid Rotate both keys 90° CW to retract bolt 2 N.C. safety contacts are in the open state 1 N.O. contact in the closed state Primary keys are trapped (guard can be accessed)	0	14 (0.55)	440T-MDBUE10xx ⁽¹⁾
				3 (0.11)	17 (0.66)	440T-MDBUE11xx ⁽¹⁾	
				6 (0.23)	20 (0.78)	440T-MDBUE12xx ⁽¹⁾	
				13 (0.51)	27 (1.06)	440T-MDBUE13xx ⁽¹⁾	
	Dual key	Bolt projected (guard is secure) Primary key 1 is free (ordered separately) 2 N.C. safety contacts are in the closed state 1 N.O. contact is in the open state Insert primary key 1 and rotate 90° CW Primary key 1 is now trapped Apply 24V DC to the solenoid Rotate secondary key 1 to 90° CCW to retract bolt 2 N.C. safety contacts are in the open state 1 N.O. contact in the closed state Secondary key is free (personal key) (guard can be accessed)	0	14 (0.55)	440T-MDBUE14xy ⁽¹⁾⁽²⁾		
		Bolt projected (guard is secure) Primary key is free (ordered separately) Secondary key is trapped (ordered separately) Spartan solenoid is energized (contacts are closed) Insert primary key and rotate 90° CW Primary key is now trapped (guard is secure) Rotate secondary key 90° CCW to retract bolt Secondary key is free (personal key)	3 (0.11)	17 (0.66)	440T-MDBUE15xy ⁽¹⁾⁽²⁾		
			6 (0.23)	20 (0.78)	440T-MDBUE16xy ⁽¹⁾⁽²⁾		
			13 (0.51)	27 (1.06)	440T-MDBUE17xy ⁽¹⁾⁽²⁾		

(1) Substitute the desired primary code for x (key not included). See [Key Coding on page 98](#) for code selection.
 (2) Substitute the desired secondary code for y (key not included). See [Key Coding on page 98](#) for code selection.

Accessories

Table 150 - Bolt Interlock Accessories

Description	Additional Information	Cat. No.
Stainless-steel key	See Accessories on page 140 .	440T-AKEYE10x ⁽¹⁾
Stainless-steel replacement code barrel for products other than 100 A RPS/RKS units		440T-ASCBE14x ⁽¹⁾
Stainless-steel weatherproof replacement dust cap		440T-ASF10x ⁽¹⁾
Stainless-steel ejector key		440T-AKEYE13x ⁽¹⁾

(1) Substitute the desired primary code for x (key not included). See [Key Coding on page 98](#) for code selection.

Figure 100 - Prosafe Bolt Lock Solenoid Locked with Electrical Isolation - One Key [mm (in.)]

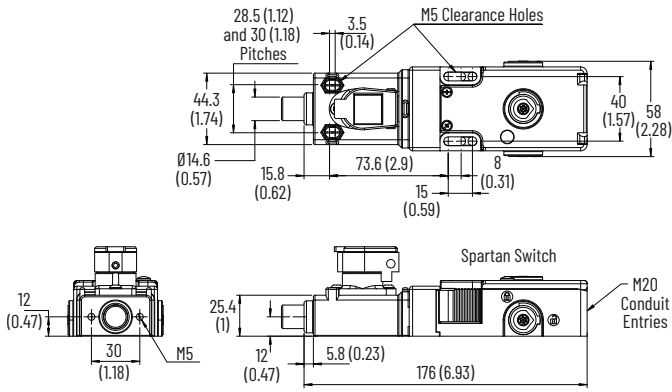
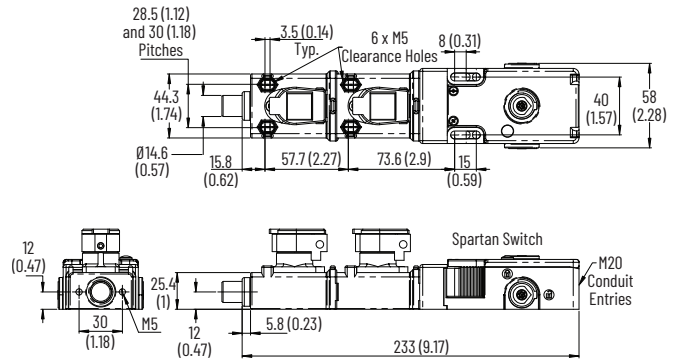

Figure 101 - Prosafe Bolt Lock Solenoid Locked with Electrical Isolation - Two Keys [mm (in.)]



Access and Chains Trapped Key Interlock Switches

The access and chains trapped key interlock switches have the following features:

- 316L stainless-steel construction
- Direct-drive operation
- Fitted with tamper resistant screws
- Lever or chain actuator
- Stainless-steel dust cap as standard
- Replaceable code barrel assembly
- Solenoid and electric versions
- Multiple key options

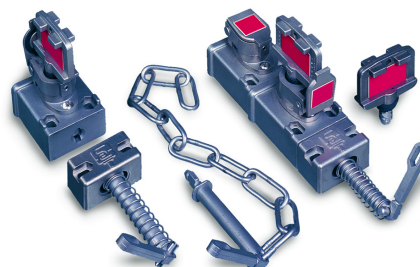

Specifications

Table 151 - Interlock Switch Specifications

Attribute	Value
Standards Classification (Safety)	EN ISO 14119 and GS-ET-31, and can be used in safety application up to category 3, PLd in accordance with EN ISO 13849-1, and in the application area of EN 60204-1.
Functional Safety Data	PFHD = 1.00E-7 (probability of dangerous failure per hr); T1 = 20 (Proof test interval)
Certifications	CE Marked for all applicable directives, UKCA Marked for all applicable regulations, and TÜV Certified rok.auto/certifications
Operating temperature	-40...+80 °C (-40...+176 °F)
Relative humidity	95%
Mechanical life	200,000 operations
Shear force to key	15.1 kN (3394.62 lbf)
Torque to key	14 N•m (10.33 lb•ft)
Material	Faceplate: 316L stainless steel
Mounting	<ul style="list-style-type: none"> • SAL and SCL: 2 or 4 x M5 counter-bored from top or 2 or 4 x M5 from underside with nuts • DAL and DCL: 4 or 6 x M5 counter-bored from top or 4 or 6 x M5 from underside with nuts
Weight	<ul style="list-style-type: none"> • SAL and SCL: 0.8 kg (1.8 lb) • DAL and DCL: 1.35 kg (3 lb)
Misalignment tolerance	±10 mm (0.39 in.)

Product Selection

Table 152 - Mechanical Interlock Switch Product Selection

Type	Actuator Type	Trapped Key Condition	Cat. No.
Single Key	Lever	Lever inserted (guard is secured) Primary key 1 is free (ordered separately) Insert primary key 1 and rotate 90° CW to release the lever Primary key 1 is now trapped (guard can be accessed)	440T-MSALE10x ⁽¹⁾
	Chain	Chain inserted (guard is secured) Primary key 1 is free (ordered separately) Insert primary key 1 and rotate 90° CW to release the chain Primary key 1 is now trapped (guard can be accessed)	440T-MSCLE10x ⁽¹⁾
	Extended Lever	Extended lever inserted (guard is secured) Primary key 1 is free (ordered separately) Insert primary key 1 and rotate 90° CW to release the lever Primary key 1 is now trapped (guard can be accessed)	440T-MSALE20x ⁽¹⁾
Single Key with Padlock Hasp	Lever	Padlock hasp lever inserted (guard is secured) Primary key 1 is free (ordered separately) Insert primary key 1 and rotate 90° CW to release the Lever Primary key 1 is now trapped (guard can be accessed)	440T-MSALE1x ⁽¹⁾
	Chain	Padlock hasp chain inserted (guard is secured) Primary key 1 is free (ordered separately) Insert primary key 1 and rotate 90° CW to release the chain Primary key 1 is now trapped (guard can be accessed)	440T-MSCLE1x ⁽¹⁾
Dual Key	Lever	Lever inserted (guard is secure) Primary keys are free (ordered separately) Insert primary key 1 into the lock, then insert primary key 2 Rotate both keys 90° CW to release the lever Primary Keys are now trapped (Guard can be accessed)	440T-MDALE10xy ⁽¹⁾⁽²⁾
		Lever inserted (guard is secure) Primary key 1 free (ordered separately) Secondary key 1 is trapped Insert primary key 1 and rotate 90° CW Rotate secondary key 1 to 90° CCW to release lever Primary key 1 is now trapped (guard is secure) Secondary key 1 is free (personal key)	440T-MDALE11xx ⁽¹⁾
	Chain	Chain inserted (guard is secure) Primary keys are free (ordered separately) Insert primary key 1 into the lock, then insert primary key 2 Rotate both keys 90° CW to release the chain Primary keys are now trapped (guard can be accessed)	440T-MDCLE10xy ⁽¹⁾⁽²⁾
		Chain inserted (guard is secure) Primary key 1 free (ordered separately) Secondary key 1 is trapped Insert primary key 1 and rotate 90° CW Rotate secondary key 1 to 90° CCW to release the chain Primary key 1 is now trapped (guard is secure) Secondary key 1 is free (personal key)	440T-MDCLE11xx ⁽¹⁾
Dual Key with Padlock Hasp	Lever	Padlock hasp lever inserted (guard is secured) Primary key 1 free (ordered separately) Secondary key 1 is trapped Insert primary key 1 and rotate 90° CW Rotate secondary key 1 to 90° CCW to release lever Primary key 1 is now trapped (guard is secure) Secondary key 1 is free (personal key)	440T-MDALE45xy ⁽¹⁾⁽²⁾
Dual Key with Eject Key	Lever	Lever inserted (guard is secure) Primary key 1 free (ordered separately) Secondary key 1 is trapped Insert primary key 1 and rotate 90° CW Rotate secondary key 1 to 90° CCW to release lever Primary key 1 is now trapped (guard is secure) Secondary Key 1 ejects free from the lock (Personal Key)	440T-MDALJ10xy ⁽¹⁾
	Chain	Chain inserted (guard is secure) Primary key 1 free (ordered separately) Secondary key 1 is trapped Insert primary key 1 and rotate 90° CW Rotate secondary key 1 to 90° CCW to release the chain Primary key 1 is now trapped (guard is secure) Secondary key 1 ejects free from the lock (personal key)	440T-MDCLJ10xy ⁽¹⁾⁽²⁾

Table 152 - Mechanical Interlock Switch Product Selection (Continued)

Type	Actuator Type	Trapped Key Condition	Cat. No.
Triple Key	Lever	Lever inserted (guard is secure) Primary key 1 free (ordered separately) Secondary key 1 and key 2 are trapped Insert primary key 1 into the lock and rotate 90° CW Rotate secondary key 1 and key 2 to 90° CCW to release Lever Primary key 1 is now trapped (guard can be accessed) Secondary key 1 and key 2 are free (personal keys)	440T-MTALE11xyy ⁽¹⁾⁽²⁾
	Chain	Chain inserted (guard is secured) Primary key 1 free (ordered separately) Secondary key 1 and key 2 are trapped Insert primary key 1 into the lock and rotate 90° CW Rotate secondary key 1 and key 2 to 90° CCW to release Lever Primary key 1 is now trapped (guard can be accessed) Secondary key 1 and key 2 are free (personal keys)	440T-MTCLE11xyy ⁽¹⁾⁽²⁾
Quad Key	Lever	Lever inserted (guard is secure) Primary keys free (ordered separately) Secondary key 1 is trapped Insert primary key 1 into the lock, then key 2, then key 3 Rotate the 3 primary keys 90° CW Rotate secondary key 1 to 90° CCW to retract bolt Primary keys are now trapped (guard can be accessed) Secondary key 1 is free (personal key)	440T-MQALE11x ⁽¹⁾
Five-way	Lever	Lever inserted (guard is secure) Primary keys free (ordered separately) Secondary key 1 is trapped Insert primary key 1 into the lock, then key 2, then key 3, then 4 Rotate the 4 primary keys 90° CW Rotate secondary key 1 to 90° CCW to release the lever Primary keys are now trapped (guard can be accessed) Secondary key 1 is free (personal key)	440T-MPALE11x ⁽¹⁾
	Ejector key	Lever inserted (guard is secure) Primary keys free (ordered separately) Secondary key 1 is trapped Insert primary key 1 into the lock, then key 2, then key 3, then 4 Rotate the 4 primary keys 90° CW Rotate secondary key 1 to 90° CCW to release the lever Primary keys are now trapped (guard can be accessed) Secondary key 1 ejects free from the lock (personal key)	440T-MPALJ11x ⁽¹⁾

(1) Substitute the desired primary code for x (key not included). See [Key Coding on page 98](#) for code selection.

(2) Substitute the desired secondary code for y (key not included). See [Key Coding on page 98](#) for code selection.

Table 153 - Electrical Interlock Switch Product Selection

Contact Type	Type	Actuator Type	Trapped Key Condition	Cat. No.
2 N.C. and 1 N.O. break before make	Dual key	Lever	Lever inserted (guard is secured) Primary keys are free (ordered separately) 2 N.C. safety contacts are in the closed state 1 N.O. contact is in the open state Insert primary key 1 into the lock then insert primary key 2 Rotate both keys, 90° CW to release the Lever 2 N.c. safety contacts are in the open state 1 N.O. contact in the closed state Primary keys are now trapped (guard can be accessed)	440T-MDASE21xx ⁽¹⁾
			Lever inserted (guard is secured) Primary key is free (ordered separately) Secondary key 1 is trapped 2 N.C. safety contacts are in the closed state 1 N.O. contact is in the open state Insert primary key 1 and rotate 90° CW Primary key 1 is now trapped Rotate secondary key 1 to 90° CCW to release the lever 2 N.C. safety contacts are in the open state 1 N.O. contact in the closed state Secondary key is free (personal key) (guard can be accessed)	440T-MDASE20xy ⁽¹⁾⁽²⁾
		Chain	Chain lever inserted (guard is secured) Primary keys are free (ordered separately) 2 N.C. safety contacts are in the closed state 1 N.O. contact is in the open state Insert primary key 1 into the lock then insert primary key 2 Rotate both keys, 90° CW to release the chain lever 2 N.C. safety contacts are in the open state 1 N.O. contact in the closed state Primary keys are now trapped (guard can be accessed)	440T-MDCSE21xx ⁽¹⁾
			Chain lever inserted (guard is secured) Primary key is free (ordered separately) Secondary key 1 is trapped 2 N.C. safety contacts are in the closed state 1 N.O. contact is in the open state Insert primary key 1 and rotate 90° CW Primary key 1 is now trapped Rotate secondary key 1 to 90° CCW to release the chain lever 2 N.C. safety contacts are in the open state 1 N.O. contact in the closed state Secondary key is free (personal key) (guard can be accessed)	440T-MDCSE20xy ⁽¹⁾⁽²⁾
	Solenoid	Lever	Lever Inserted - contacts closed (guard is secure) Primary key 1 is free (ordered separately) Secondary key 1 trapped 2 N.C. safety contacts are in the closed state 1 N.O. contact is in the open state Insert primary key 1 and rotate 90° CW Primary key 1 is now trapped Apply 24V DC to the solenoid Rotate secondary key 1 to 90° CCW to release the lever 2 N.C. safety contacts are in the open state 1 N.O. contact in the closed state Secondary key 1 is free (personal key) (guard can be accessed)	440T-MDAUE20x ⁽¹⁾

(1) Substitute the desired primary code for x (key not included). See [Key Coding on page 98](#) for code selection.
 (2) Substitute the desired secondary code for y (key not included). See [Key Coding on page 98](#) for code selection.

Accessories

Table 154 - Interlock Switch Accessories

Description	Additional Information	Cat. No.
Stainless-steel key	See Accessories on page 140 .	440T-AKEYE10x ⁽¹⁾
Stainless-steel replacement code barrel for products other than 100 A RPS/RKS units		440T-ASCBE14x ⁽¹⁾
Stainless-steel weatherproof replacement dust cap		440T-ASFC10x ⁽¹⁾
Replacement spare block catch		440T-ACAD10
Replacement spare chain catch		440T-ACHA10
Stainless-steel ejector key		440T-AKEYE13x ⁽¹⁾

(1) Substitute the desired primary code for x (key not included). See [Key Coding on page 98](#) for code selection.

Approximate Dimensions

Dimensions are not intended to be used for installation purposes.

Figure 102 - Mechanical, Single Key, Lever Actuator [mm (in.)]

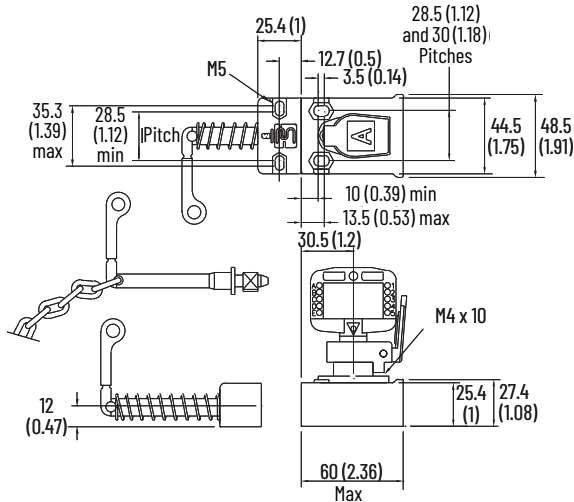

Figure 103 - Mechanical, Dual Key, Lever Actuator [mm (in.)]

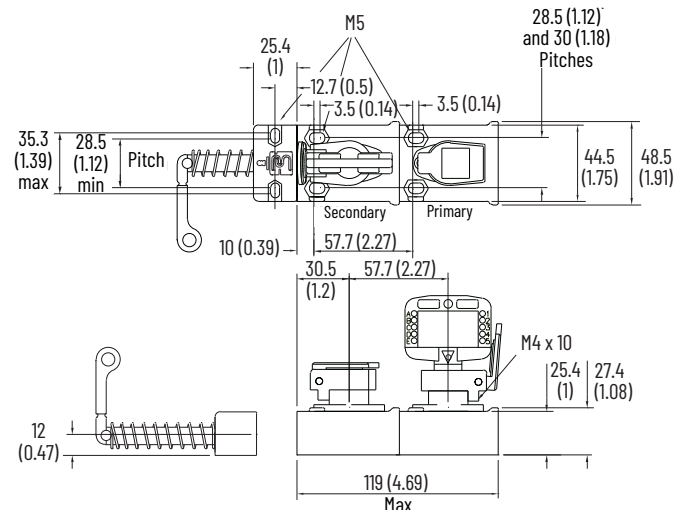

Figure 104 - Mechanical, Five Way, Lever Actuator [mm (in.)]

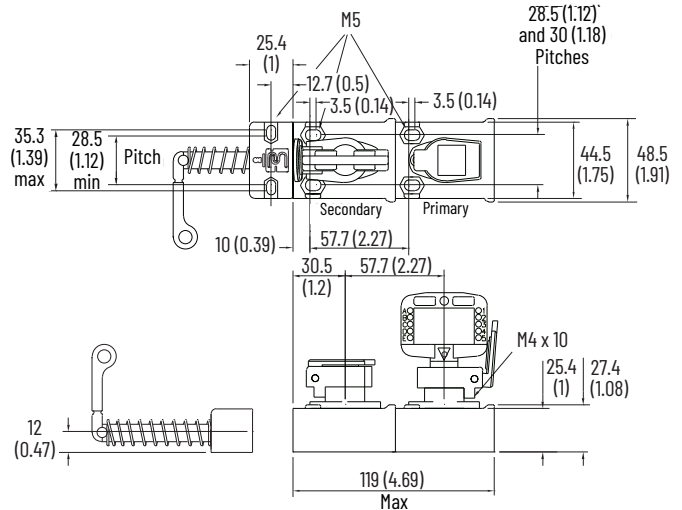

Figure 105 - Electrical, Dual Key, Chain Actuator [mm (in.)]

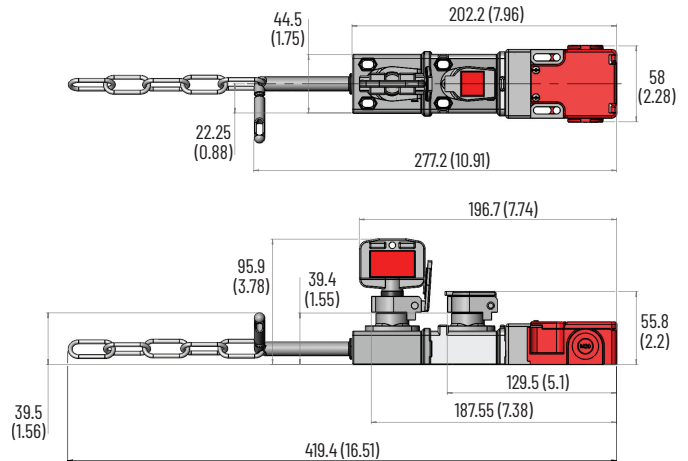

Figure 106 - Electrical, Dual Key, Lever Actuator [mm (in.)]

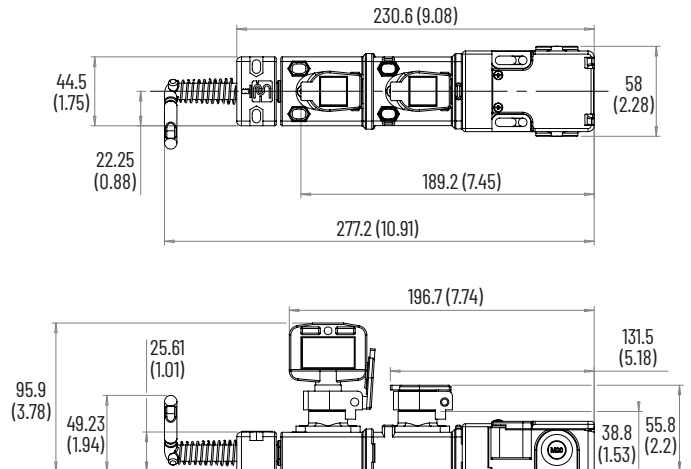
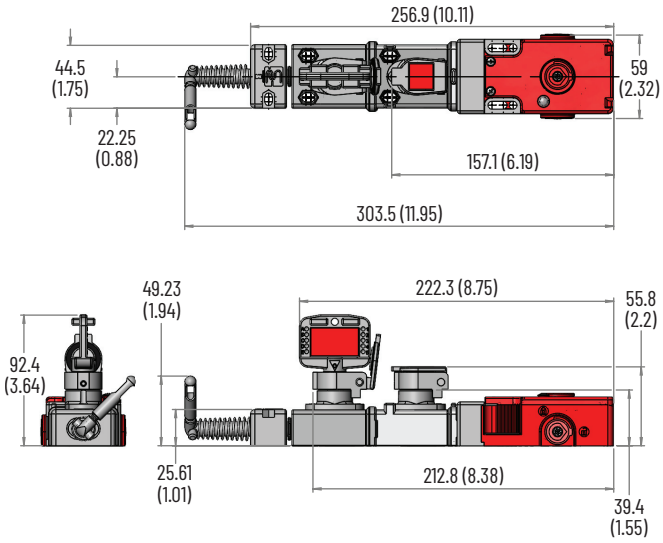

Figure 107 - Solenoid, Dual Key, Lever Actuator [mm (in.)]



Prosafe Slamlock Mechanical Interlock Switches

The Prosafe® Slamlock™ mechanical interlock switches have the following features:

- 316L stainless-steel construction
- Selection of actuator types available
- Direct-drive operation
- Replaceable code barrel assembly
- Fitted with tamper resistant screws
- Weatherproof stainless-steel dust cap as standard
- Multiple key options

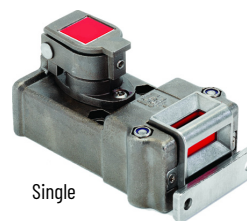

Single

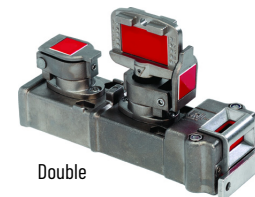

Double

Specifications

Table 155 - Interlock Switch Specifications

Attribute	Value
Standards Classification (Safety)	EN ISO 14119 and GS-ET-31, and can be used in safety application up to category 3, PLD in accordance with EN ISO 13849-1, and in the application area of EN 60204-1.
Functional Safety Data	PFHD = 1.00E-7 (probability of dangerous failure per hr); T1 = 20 (Proof test interval)
Certifications	CE Marked for all applicable directives, UKCA Marked for all applicable regulations, and TÜV Certified rok.auto/certifications
Operating temperature	-40...+80 °C (-40...+176 °F)
Relative humidity	95%
Mechanical life	200,000 operations
Shear force to key, max	15.1 kN (3394.62 lbf)
Torque to key, max	14 N•m (10.33 lb•ft)
Material	316L stainless steel
Mounting	<ul style="list-style-type: none"> • SSL: 2 x M5 counter-bored from top or 2 x M5 from underside with nuts • DSS: 4 x M5 counter-bored from top or 4 x M5 from underside with nuts
Weight	<ul style="list-style-type: none"> • Single key: 0.76 kg (1.68 lb) • Dual key: 1.33 kg (2.93 lb)
Holding force, max	2000 N (450 lb)

Product Selection

Table 156 - Interlock Switch Product Selection

Type	Actuator Type	Trapped Key Condition	Cat. No.
Single key	Standard	Actuator inserted (guard is secure) Primary key 1 free (ordered separately)	440T-MSSLE10x ⁽¹⁾
	Flexible	Insert primary key 1 and rotate 90° CW Actuator is released	440T-MSSLE11x ⁽¹⁾
	Flat	Primary key is now trapped (guard can be accessed)	440T-MSSLE12x ⁽¹⁾
Dual key	Standard	Actuator inserted (guard is secure) Primary keys are free (ordered separately)	440T-MDSLE10xy ⁽¹⁾⁽²⁾
	Flexible	Insert primary key 1 into the lock, then insert primary key 2 Rotate both keys 90° CW to release the actuator	440T-MDSLE11xy ⁽¹⁾⁽²⁾
	Flat	Primary Keys are now trapped (Guard can be accessed)	440T-MDSLE12xy ⁽¹⁾⁽²⁾
	Standard	Actuator inserted (guard is secure) Primary key 1 free (ordered separately)	440T-MDSLE20xx ⁽¹⁾
	Flexible	Secondary key 1 is trapped Insert primary key 1 and rotate 90° CW	440T-MDSLE22xx ⁽¹⁾
	Flat	Rotate secondary key 1 to 90° CCW to release actuator Primary key 1 is now trapped (guard is secure) Secondary key 1 is free (personal key)	440T-MDSLE23xx ⁽¹⁾
	Standard	Actuator inserted (guard is secure) Primary key 1 free (ordered separately)	440T-MDSW10xx ⁽¹⁾⁽²⁾
	Flexible	Secondary key 1 is trapped Insert primary key 1 and rotate 90° CW	440T-MDSW11xx ⁽¹⁾⁽²⁾
	Flat	Rotate secondary key 1 to 90° CCW to release actuator Primary key 1 is now trapped (guard is secure) Secondary key 1 ejects free from the lock (personal key)	440T-MDSW12xx ⁽¹⁾⁽²⁾
Dual with secondary ejector key	Standard	Primary key trapped, secondary key free to release actuator	440T-MDSLJ10xy ⁽¹⁾⁽²⁾
	Flexible		440T-MDSLJ14xy ⁽¹⁾⁽²⁾
	Flat		440T-MDSLJ12xy ⁽¹⁾⁽²⁾

(1) Substitute the desired primary code for x (key not included). See [Key Coding on page 98](#) for code selection.

(2) Substitute the desired secondary code for y (key not included). See [Key Coding on page 98](#) for code selection.

Accessories

Table 157 - Interlock Switch Accessories

Description	Additional Information	Cat. No.
Stainless-steel key	See Accessories on page 140 .	440T-AKEYE10x ⁽¹⁾
Stainless-steel replacement code barrel for products other than 100 A RPS/RKS units		440T-ASCBE14x ⁽¹⁾
Stainless-steel weatherproof replacement dust cap		440T-ASF10x ⁽¹⁾
GD2 standard actuator		440G-A27011
GD2 flat actuator		440K-A11112
Fully flexible actuator		440G-A27143
Stainless-steel ejector key		440T-AKEYE13x ⁽¹⁾

(1) Substitute the desired primary code for x (key not included). See [Key Coding on page 98](#) for code selection.

Approximate Dimensions

Dimensions are not intended to be used for installation purposes.

Figure 108 - Single Key Slamlock [mm (in.)]

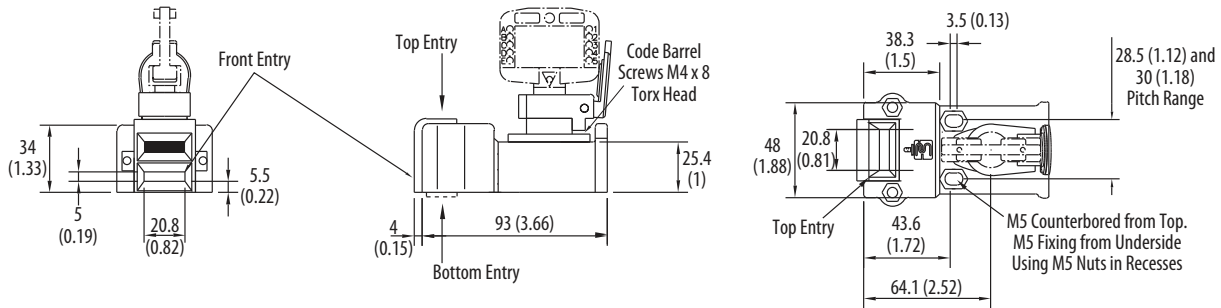

Figure 109 - Dual Key Slamlock [mm (in.)]

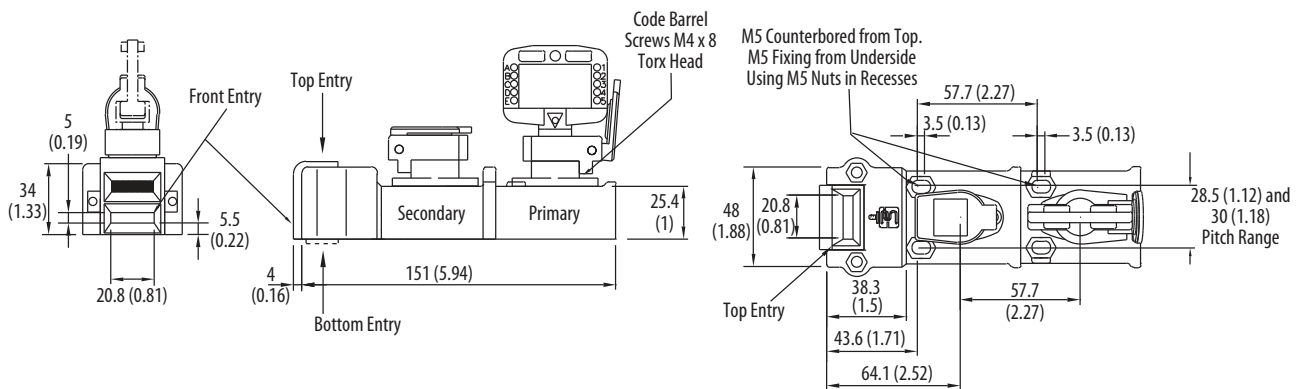
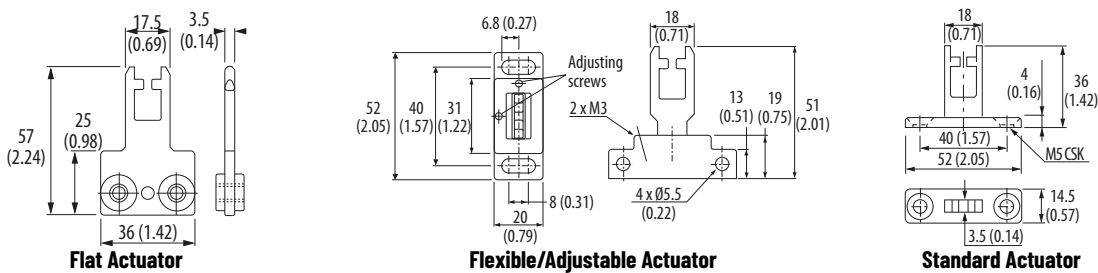

Figure 110 - Actuators [mm (in.)]



Prosafe Slamlock Electrical Interlock Switches

The Prosafe Slamlock electrical interlock switches have the following features:

- Electrical safety contacts combined with trapped key/enforced sequence feature
- Most of the unit is constructed from 316L stainless steel
- Selection of actuator types available
- Single or dual key versions available
- Direct-drive operation
- Replaceable code barrel assembly
- Weatherproof stainless-steel dust cap as standard
- Solenoid versions

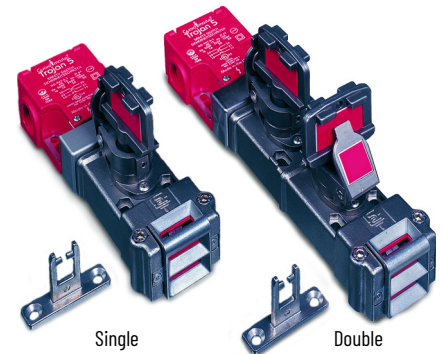

Specifications

Table 158 - Interlock Switch Specifications

Attribute	Value		
Standards Classification (Safety)	EN ISO 14119 and GS-ET-31, and can be used in safety application up to category 3, PLd in accordance with EN ISO 13849-1, and in the application area of EN 60204-1.		
Functional Safety Data	PFHD = 1.00E-7 (probability of dangerous failure per hr); T1 = 20 (Proof test interval)		
Certifications	CE Marked for all applicable directives, UKCA Marked for all applicable regulations, and TÜV Certified rok.auto/certifications		
Operating temperature	-20...+80 °C (-4...+176 °F)		
Relative humidity	95%		
Mechanical life	200,000 operations		
Shear force to key, max	15.1 kN (3394.62 lbf)		
Torque to key, max	14 N•m (10.33 lb•ft)		
Case material	<ul style="list-style-type: none"> • 316L stainless steel • UL approved glass-filled polyester 		
Actuator material	Stainless steel		
Mounting	<ul style="list-style-type: none"> • SSS: 4 x M5 counter-bored from top or 4 x M5 from underside with nuts • DSS: 6 x M5 counter-bored from top or 6 x M5 from underside with nuts 		
Weight	<ul style="list-style-type: none"> • SSE: 1160 kg (2.6 lb) • DSSE: 1700 kg (3.7 lb) 		
Holding force, max	2000 N (450 lb)		
Releasable load, max	100 N (22.5 lb)		
Safety contacts	2 N.C. positive break		
AC 15–Ue	500V	250V	100V
AC 15–Ie	1 A	2 A	5 A
DC	250V	0.5 A, 24V	2 A
Switching current at voltage, max	500V/500V A		
Thermal current (I_{th})	10 A		
Current, min	5V, 5 mA, DC		
Safety contact gap	>2 x 2 mm (0.07 in)		
Rated insulation voltage	(Ui) 500V		
Rated impulse withstand voltage	(Uimp) 2500V		
Auxiliary contacts	1 N.O.		
Pollution degree	3		
Actuator travel for positive opening	5 mm (0.19 in)		
Operating radius, min	175 mm (6.88 in) (60 mm (2.36 in) with flexible actuator)		
Break contact force, min	12 N (2.7 lbs)		
Actuation speed, max	1 m/s		
Actuation frequency, max	2 cycle/s		
Conduit entry	3 x M20		
Color	Red/stainless		

Product Selection

Table 159 - Electrical Interlock Switch Product Selection

Contact Type	Type	Actuator Type	Trapped Key Condition	Connector	Cat. No.
2 N.C. + 1 N.O. Break before make	Single Key	Standard	Actuator inserted - contacts closed (guard is secure) Primary key 1 is free (ordered separately) 2 N.C. safety contacts are in the closed state 1 N.O. contact is in the open state	QD M12 (6-pin dual key)	440T-MS3470x ⁽¹⁾
		Flexible	Insert the primary 1 key and rotate 90° CW to release the actuator 2 N.C. safety contacts are in the open state		440T-MSSSE10x ⁽¹⁾
		Flat	1 N.O. contact in the closed state Primary key 1 is now trapped (guard can be accessed)		440T-MSSSE11x ⁽¹⁾
		Standard	Actuator inserted - contacts closed (guard is secure) Primary key 1 trapped		440T-MSSSE12x ⁽¹⁾
		Flexible	2 N.C. safety contacts are in the closed state 1 N.O. contact is in the open state		440T-MSSSE20x ⁽¹⁾
		Flat	Rotate primary key 1 to 90° CCW to release the actuator 2 N.C. safety contacts are in the open state 1 N.O. contact in the closed state Key is now free (guard can be accessed)		440T-MSSSE22x ⁽¹⁾
	Dual Key	Standard	Actuator inserted - contacts closed (guard is secure) Primary keys are free (ordered separately) 2 N.C. safety contacts are in the closed state 1 N.O. contact is in the open state	M20 conduit entry	440T-MDSSE10xy ⁽¹⁾⁽²⁾
		Flexible	Insert primary key 1 into the lock then insert primary key 2 Rotate both keys 90° CW to release the actuator 2 N.C. safety contacts are in the open state 1 N.O. contact in the closed state Primary keys are now trapped (guard can be accessed)		440T-MDSSE11xy ⁽¹⁾⁽²⁾
		Flat	Actuator inserted - contacts closed (guard is secure) Primary keys are free (ordered separately) Secondary key 1 is trapped 2 N.C. safety contacts are in the closed state 1 N.O. contact is in the open state		440T-MDSSE12xy ⁽¹⁾⁽²⁾
		Standard	Insert primary key 1 and rotate 90° CW Primary key 1 is now trapped Rotate secondary key 1 to 90° CCW to release the actuator 2 N.C. safety contacts are in the open state 1 N.O. contact in the closed state Secondary key 1 ejects free from the lock (personal key)		440T-MDSSJ10xy ⁽¹⁾⁽²⁾
		Flexible	Actuator inserted - contacts closed (guard is secure) Primary keys are free (ordered separately) Secondary key 1 is trapped 2 N.C. safety contacts are in the closed state 1 N.O. contact is in the open state		440T-MDSSJ11xy ⁽¹⁾⁽²⁾
		Flat	Insert the primary key 1 and rotate 90° CW Primary key 1 is now trapped Rotate secondary key 1 to 90° CCW to release the actuator 2 N.C. safety contacts are in the open state 1 N.O. contact in the closed state Secondary key is free (personal key) (guard can be accessed)		440T-MDSSJ12xy ⁽¹⁾⁽²⁾
2 N.C. + 2 N.O. Break before make	Single key	Standard	Actuator inserted - contacts closed (guard is secure) Primary keys are free (ordered separately)	440T-MDSSE20xx ⁽¹⁾	
		Flexible	Secondary key 1 is trapped 2 N.C. safety contacts are in the closed state 1 N.O. contact is in the open state	440T-MDSSE22xx ⁽¹⁾	
		Flat	Insert the primary key 1 and rotate 90° CW Primary key 1 is now trapped Rotate secondary key 1 to 90° CCW to release the actuator 2 N.C. safety contacts are in the open state 1 N.O. contact in the closed state Primary key 1 is now trapped (guard can be accessed)	440T-MDSSE23xx ⁽¹⁾	
2 N.C. + 2 N.O. Break before make	Single key	Standard	Actuator inserted - contacts closed (guard is secure) Primary keys are free (ordered separately)	440T-MSSSE26x ⁽¹⁾	
		Flexible	2 N.C. safety contacts are in the closed state 2 N.O. contact is in the open state	440T-MSSSE27x ⁽¹⁾	
		Flat	Insert the primary 1 key and rotate 90° CW to release the actuator 2 N.C. safety contacts are in the open state 1 N.O. contact in the closed state Primary key 1 is now trapped (guard can be accessed)	440T-MSSSE25x ⁽¹⁾	

(1) Substitute the desired primary code for x (key not included). See [Key Coding on page 98](#) for code selection.
 (2) Substitute the desired secondary code for y (key not included). See [Key Coding on page 98](#) for code selection.

Table 160 - Solenoid Interlock Switch Product Selection

Contact Type	Type	Trapped Key Condition	Solenoid Voltage	Actuator Type	Connector	Cat. No.
2 N.C. + 1 N.O. Break before make	Single key	Actuator inserted - contacts closed (guard is secure) Primary key 1 is free (ordered separately) 2 N.C. safety contacts are in the closed state 1 N.O. contact is in the open state Apply 24V DC to the solenoid Insert the primary 1 key and rotate 90° CW to release the actuator 2 N.C. safety contacts are in the open state 1 N.O. contact in the closed state Primary key 1 is now trapped (guard can be accessed)	24V DC	Standard	M23 (12-pin)	440T-MS3465x ⁽¹⁾
				Flexible		440T-MSSUE20x ⁽¹⁾
				Flat		440T-MSSUE22x ⁽¹⁾
	Dual key	Actuator inserted - contacts closed (guard is secure) Primary key 1 is free (ordered separately) Secondary key 1 trapped 2 N.C. safety contacts are in the closed state 1 N.O. contact is in the open state Apply 24V DC to the solenoid Insert primary key 1 and rotate 90° CW Primary Key 1 is now Trapped Apply 24V DC to the solenoid Rotate secondary key 1 to 90° CCW to release the actuator 2 N.C. safety contacts are in the open state 1 N.O. contact in the closed state Secondary key 1 is free (personal key) (guard can be accessed)	24V DC	Standard	M20 conduit entry	440T-MDSUE10x ⁽¹⁾
				Flexible		440T-MDSUE11x ⁽¹⁾
				Flat		440T-MSSUE12x ⁽¹⁾
	Single key	Actuator inserted - contacts closed (guard is secure) Primary key 1 is free (ordered separately) 2 N.C. safety contacts are in the closed state 1 N.O. contact is in the open state Apply 110V AC to the solenoid Insert the primary 1 key and rotate 90° CW to release the actuator 2 N.C. safety contacts are in the open state 1 N.O. contact in the closed state Primary key 1 is now trapped (guard can be accessed)	110V AC	Standard		440T-MSSUE50x ⁽¹⁾

(1) Substitute the desired primary code for x (key not included). See [Key Coding on page 98](#) for code selection.

Accessories

Table 161 - Interlock Switch Accessories

Description	Additional Information	Cat. No.
Stainless-steel key	See Accessories on page 140 .	440T-AKEYE10x ⁽¹⁾
Stainless-steel replacement code barrel for products other than 100 A RPS/RKS units		440T-ASCB14x ⁽¹⁾
Stainless-steel weatherproof replacement dust cap		440T-ASFC10x ⁽¹⁾
GD2 standard actuator		440G-A27011
GD2 flat actuator		440K-AT1112
Fully flexible actuator		440G-A27143
Stainless-steel ejector key		440T-AKEYE13x ⁽¹⁾

(1) Substitute the desired primary code for x (key not included). See [Key Coding on page 98](#) for code selection.

Approximate Dimensions

Dimensions are not intended to be used for installation purposes.

Figure 111 - Electrical Single Key Slamlock [mm (in.)]

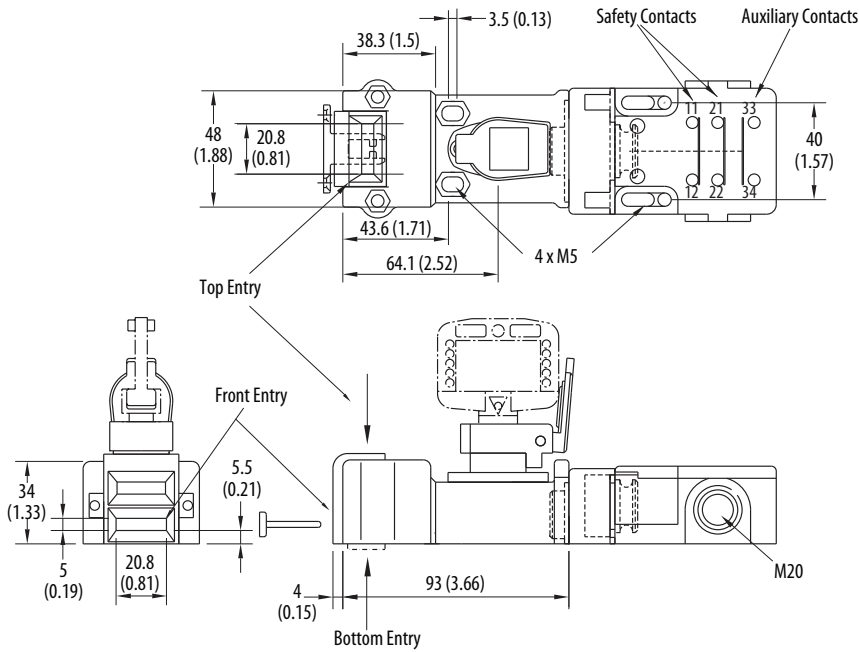

Figure 112 - Electrical Dual Key Slamlock [mm (in.)]

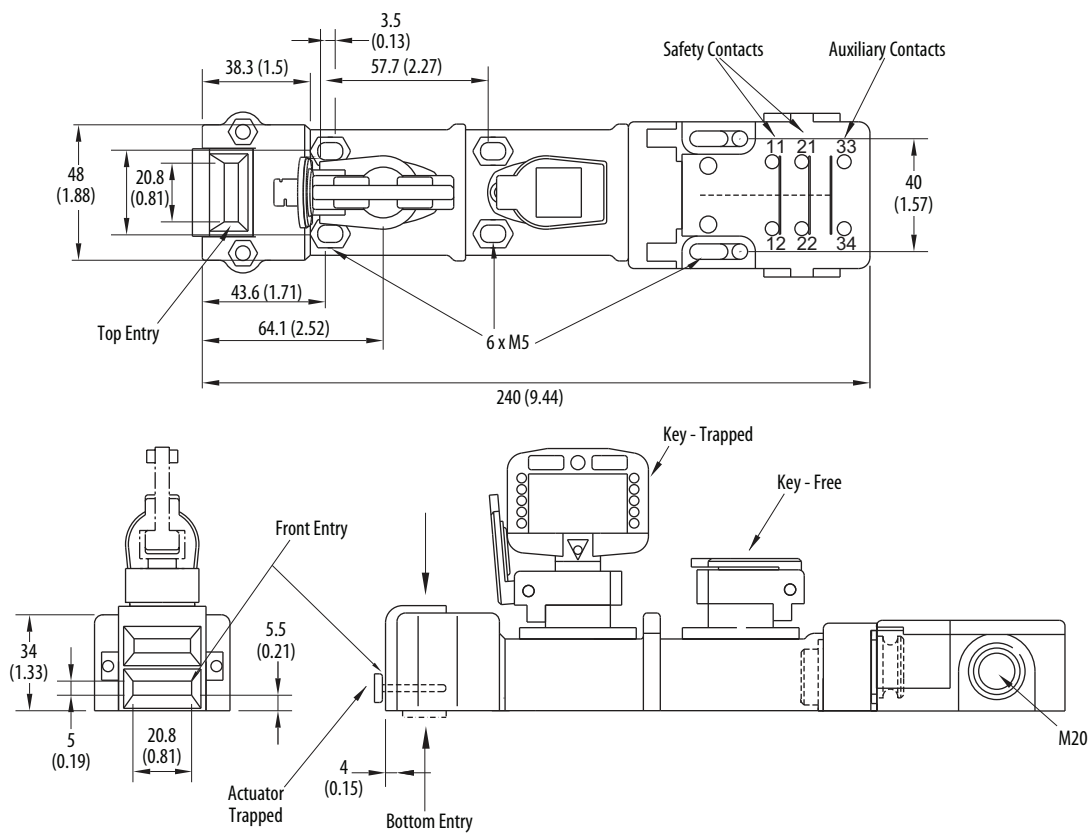

Figure 113 - Solenoid Single Key Slamlock [mm (in.)]

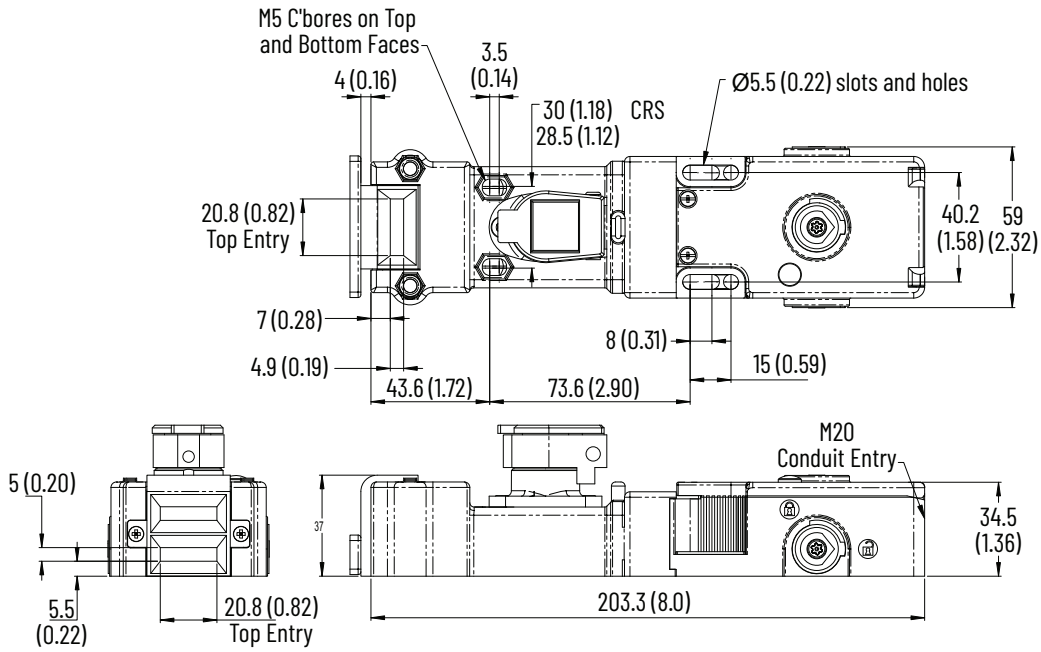
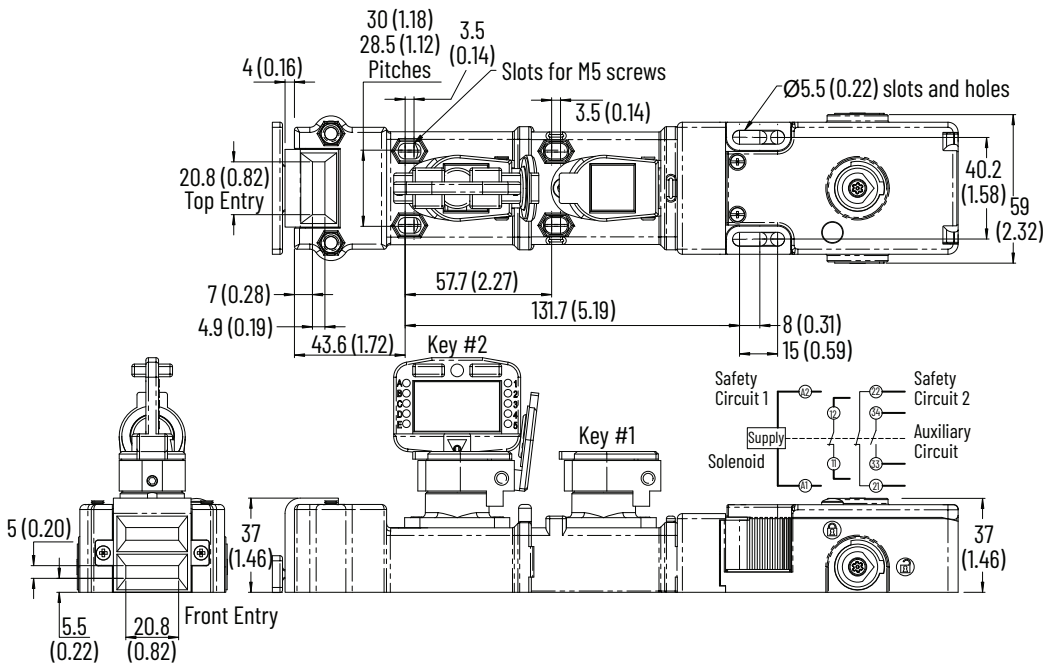

Figure 114 - Solenoid Double Key Slamlock [mm (in.)]



Miniature Valve Trapped Key Interlock Switches

The miniature valve trapped key interlock switches have the following features:

- Direct-drive operation
- Supplied with valves 0.25...2 inch
- Direct body mounting with security screws
- Locked open or locked closed options
- Lower maintenance cost
- Weatherproof stainless-steel dust cap as standard
- Replaceable code barrel assembly
- Valve is chrome-plated brass

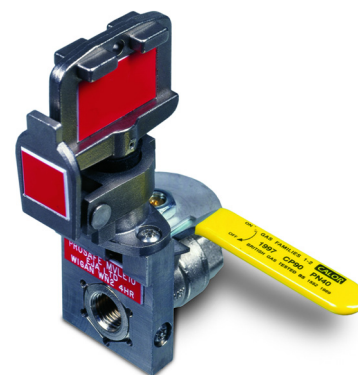

Specifications

Table 162 - Interlock Switch Specifications

Attribute	Value
Standards Classification (Safety)	EN ISO 14119 and GS-ET-31, and can be used in safety application up to category 3, PLd in accordance with EN ISO 13849-1, and in the application area of EN 60204-1.
Functional Safety Data	PFHD = 1.00E-7 (probability of dangerous failure per hr); T1 = 20 (Proof test interval)
Certifications	CE Marked for all applicable directives, UKCA Marked for all applicable regulations, and TÜV Certified rok.auto/certifications
Operating temperature	-40...+80 °C (-40...+176 °F)
Relative humidity	25...95%
Mechanical life	200,000 operations
Shear force to key, max	15.1 kN (3394.62 lbf)
Torque to key, max	14 N·m (10.33 lb·ft)
Pressure, max	2100 kPa
Material	316L stainless steel

Product Selection

Table 163 - Interlock Switch Product Selection

Valve Size - Inch BSP ⁽¹⁾	Valve Status	Cat. No. ⁽²⁾
0.25	Key free/valve locked closed	440T-VMVLE10x
0.375		440T-VMVLE11x
0.5		440T-VMVLE12x
0.25	Key free/valve locked open	440T-VMVLE13x
0.375		440T-VMVLE14x
0.5		440T-VMVLE15x
1.0	Key free/valve locked closed	440T-VMVLE18x
	Key free/valve locked open	440T-VMVLE19x

(1) BSP = British standard pipe threads

(2) Substitute the desired primary code for x (key not included). See [Key Coding on page 98](#) for code selection.

Approximate Dimensions

Dimensions are not intended to be used for installation purposes.

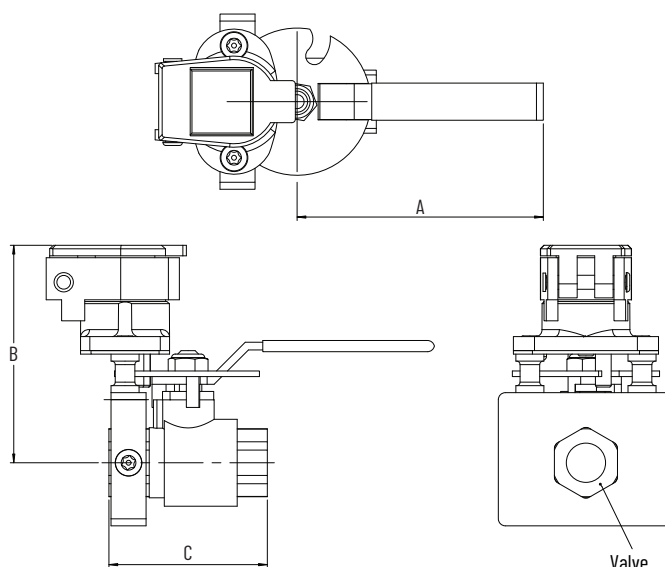

Cat. No.	[mm (in.)]			Valve Size	Pressure [bar (kg/cm ²)]
	A	B	C		
440T-VMVLE10	70 [2.75]	62 [2.44]	45 [1.77]	0.25 in. BSP	40
440T-VMVLE11			47 [1.85]	0.375 in. BSP	50
440T-VMVLE12	96 [3.78]	64 [2.52]	62 [2.44]	0.5 in. BSP	40
440T-VMVLE13	70 [2.75]	62 [2.44]	45 [1.77]	0.25 in. BSP	40
440T-VMVLE14			47 [1.85]	0.375 in. BSP	50
440T-VMVLE15	96 [3.78]	64 [2.52]	62 [2.44]	0.5 in. BSP	40
440T-VMVLE18	110 [4.33]	71 [2.79]	84 [3.31]	1 in. BSP	40
440T-VMVLE19					
440T-VMVLE20	162 [6.38]	96 [3.78]	125 [4.92]	2 in. BSP	40
440T-VMVLE21					

Switchgear Adapters

The trapped key switchgear adapters have the following feature:

- Lower maintenance cost



Specifications

Table 164 - Switchgear Adapter Specifications

Attribute	Value
Standards Classification (Safety)	EN ISO 14119 and GS-ET-31, and can be used in safety application up to category 3, PLd in accordance with EN ISO 13849-1, and in the application area of EN 60204-1.
Functional Safety Data	PFHD = 1.00E-7 (probability of dangerous failure per hr); T1 = 20 (Proof test interval)
Certifications	CE Marked for all applicable directives, UKCA Marked for all applicable regulations, and TÜV Certified rok.auto/certifications
Operating temperature	-10...+50 °C (14...122 °F)
Mechanical life	200,000 operations
Shear force to key, max	15.1 kN (3394.62 lbf)
Torque to key, max	14 N·m (10.33 lb·ft)
Relative humidity	95%
Weight [kg (lb)]	316L stainless steel
Mounting	2 x M4
Shaft dimensions	3/8 in. ² x 7/8 in. long (standard) 9/16 in. diameter x 7/8 in. long (optional, contact your local Allen-Bradley distributor or Rockwell Automation sales office.)

Product Selection

Table 165 - Switchgear Adapter Product Selection (3/8 sq shaft)

Mounting	Trap Direction	Cat. No.
2 x M4	65° clockwise to trap	440T-MSGAU10
	65° counterclockwise to trap	440T-MSGAU11
	90° clockwise to trap	440T-MSGAU12
	90° counterclockwise to trap	440T-MSGAU13
	±90° counterclockwise to trap	440T-MSGAU14
	45° clockwise to trap	440T-MSGAU17
	45° counterclockwise to trap	440T-MSGAU18
	90° clockwise to trap	440T-MSGAU19
	90° counterclockwise to trap	440T-MSGAU20
	90° clockwise to trap	440T-MSGAU21
	90° clockwise to trap	440T-MSGAU23

Accessories

Table 166 - Switchgear Adapter Accessories

Description	Additional Information	Cat. No. (1)
Stainless-steel key	See Accessories on page 140 .	440T-AKEYE10x
Stainless-steel replacement code barrel for products other than 100 A RPS/RKS units		440T-ASCBE14x
Stainless-steel weatherproof replacement dust cap		440T-ASFC10x

(1) Substitute the desired primary code for x (key not included). See [Key Coding on page 98](#) for code selection.



WARNING: The presence of spare keys, override keys, or spare actuators can compromise the integrity of safety interlocking systems. Personal injury or death, property damage, or economic loss can result from the introduction of spare keys, override keys or spare actuators into interlocking systems without appropriate management controls, working procedures and alternative protective measures to control their use and availability.

Approximate Dimensions

Dimensions are not intended to be used for installation purposes.

Figure 115 - 440T-MSGAU1x and 440T-MSGAU22x [mm (in.)]

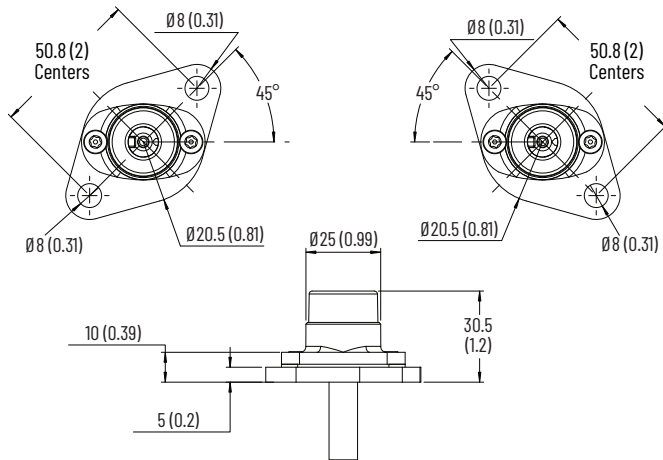

Figure 116 - 440T-MSGAU20x [mm (in.)]

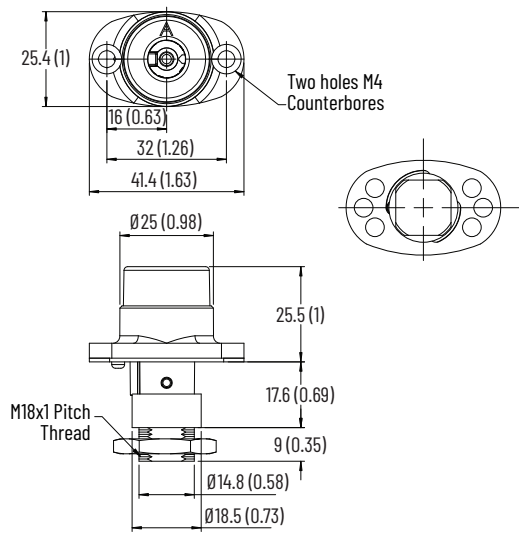

Figure 117 - 440T-MSGAU21x [mm (in.)]

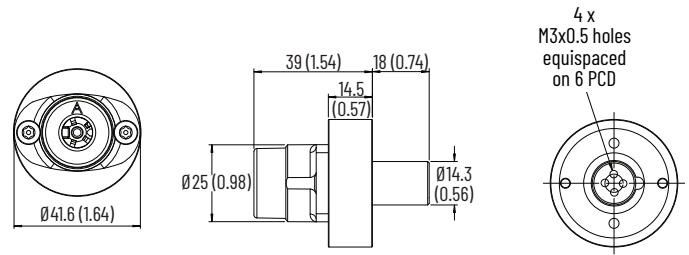
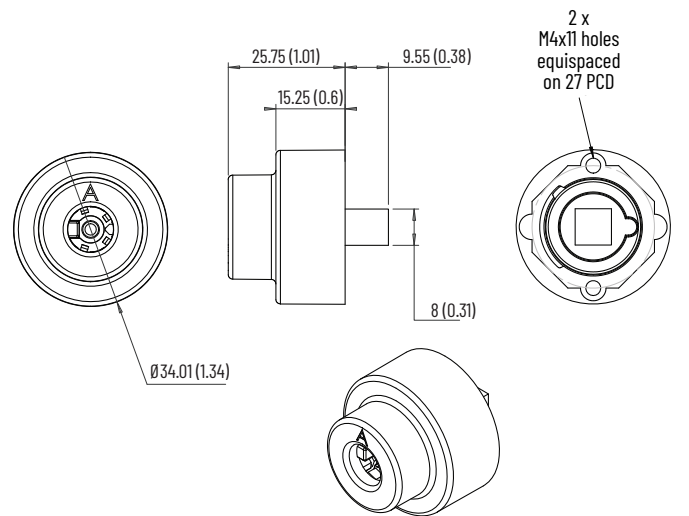

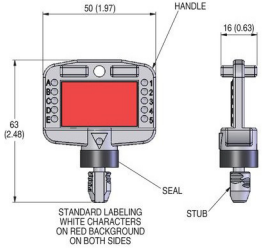

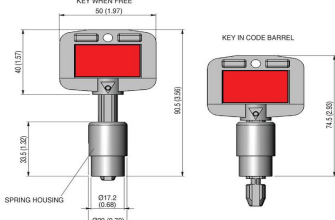

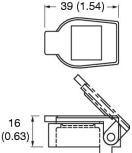

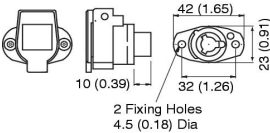

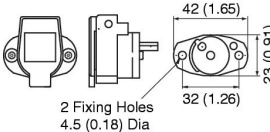



Figure 118 - 440T-MSGAU23x [mm (in.)]



Accessories

Table 167 - Switchgear Adapter Accessories

	Description		Cat. No.
	Stainless-steel key		440T-AKEYE10x ⁽¹⁾
	Stainless-steel ejector key		440T-AKEYE13x ⁽¹⁾
	Stainless-steel ejector key		440T-ASFC10x ⁽¹⁾
	Stainless-steel replacement code barrel for 100 A unit rotary switch		440T-ASCBE11x ⁽¹⁾
	Stainless-steel replacement code barrel with dust cap ⁽²⁾		440T-ASCBE14x ⁽¹⁾
	Emergency break glass key box	Plastic case	440T-AIPB11
		Metal case with hammer	440T-AIPB12
	Emergency repair kit for code barrels ⁽²⁾	ER1	440T-AKITE45ER1
		ER2	440T-AKITE45ER2
		ER3	440T-AKITE45ER3
		ER4	440T-AKITE45ER4
		ER5	440T-AKITE45ER5
		ER6	440T-AKITE45ER6
		ER7	440T-AKITE45ER7
		ER8	440T-AKITE45ER8
		ER9	440T-AKITE45ER9

(1) Substitute the desired primary code for x (key not included). See [Key Coding on page 98](#) for code selection.

(2) Not suitable for 440T-MRKSE14/440T-MRPSE14 OR 440T-MSGAU units.

442G Multi-functional Access Box

The multi-functional access boxes have the following feature:

- High holding force 2000 N (Fzh per ISO 14119) is suitable for a wide range of guarding applications
- Unique RFID coded bolt actuator achieves the highest level of tamper-resistance
- Two models available: Power to Release and Power to Lock
- Available with up to four controls and indicators including an E-stop push button
- Optional escape release allows a person who is locked inside the safeguarded area to exit quickly and easily
- Four status indicators for local status and diagnostics
- Outputs for door position, bolt position, and lock status
- Two integrated hasps included to affix padlocks
- Can be operated as a standalone device or in series with other devices

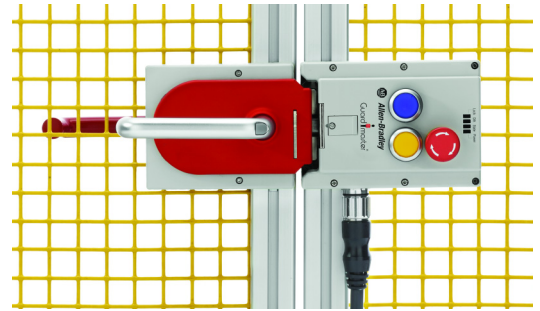

Specifications

Table 168 - Access Box Specifications





Attribute	Value
Safety ratings	
Standards	IEC 60947-5-3, EN ISO 13849-1, ISO 14119, UL 508 (evaluated for risks of electrical shock and fire; only suitable for NFPA 79 applications only)
Safety classification	Type 4 interlocking device with guard locking and high-coded RFID actuators according to ISO 14119
Functional safety data	PFH: 2.47×10^{-8} ; PLe, Cat. 4 (according to ISO 13849-1). Mission time: 20 years. B10d for E-stop: 1.0×10^5 cycles
Certifications	cULus (UL 508) Listed, UKCA Marked for all applicable regulations, and CE Marked for all applicable EU Directives
Outputs	
Safety outputs (F01A/F01B)	Semiconductor outputs, PNP
Output current, max (each)	200 mA
Output voltage U_{F01A} / U_{F01B}^1 at 50 mA switching current	ON: $U_B - 2V \dots U_B$ OFF: $0 \dots 1V$ DC
Monitoring outputs	
Monitoring outputs (OD, OT, OL, OI)	P-switching and short circuit-proof
Output voltage	$U_A - 2V \dots U_A$
Maximum load (each)	50 mA, maximum
Controls and Indicators	
Operating voltage	5...24V DC
Operating current	1...100 mA
Breaking capacity, max	250 mW
Power supply status indicator	24V DC
Operating characteristics	
Torque settings, max	1 N•m (8.85 lb•in) lock module cover screws (6x) 0.5 N•m (4.43 lb•in) manual release locking screw 2 N•m (17.7 lb•in) handle set screw (handle and escape release)
Locking force Fmax	2600 N (584.5 lbf)
Holding force Fzh	2000 N (449.6 lbf)

Table 168 - Access Box Specifications (Continued)

Attribute	Value
Maximum impact energy withstands	300 J
Locking bolt alignment tolerance	Horizontal: ± 4 mm (0.16 in.) Vertical: ± 5 mm (0.2 in.)
Operating voltage U_B	Class 2 PELV 24V DC +10/-15% required
Auxiliary power U_A	Class 2 PELV 24V DC +10/-15% required
Protection type	Short circuit and reverse polarity protected, cross fault detection
Current consumption I_{UB} (no load on any outputs)	80 mA
Current Consumption I_{UA}	
With energized guard locking solenoid and unloaded outputs OI, OL, OT, and OD	350 mA
Push button (no load, per status indicator)	5 mA
External fuse	See publication 442G-UM002
Response time (on)	570 ms
Risk time (per IEC 60947-5-3)	350 ms
Discrepancy time	10 ms (maximum)
Start-up time (availability)	0.5 s configured for standalone operation 8 s configured for series operation
Maximum length of switch chain	10 MAB devices
Utilization category (IEC 60947-5-2)	DC-13 24V 200 mA
Insulation voltage U_i (IEC 60947-1)	30V
Impulse withstand voltage U_{imp}	1.5 kV
Pollution degree (IEC 60947-1)	3
Manual release	Built in accordance with ISO 14119
Mechanical life	1,000,000 operations
Environmental	
Ambient temperature at $U_B = DC 24V$	-20...+55 °C (-4...+131 °F)
Storage temperature	-20...+65 °C (-4...+149 °F)
Enclosure rating	IP65
Operating humidity	5...80% relative
Vibration/shock	Resilience to vibration in accordance with EN IEC 60947-5-3
Physical Characteristics	
Weight	Lock module with cover 750 g (26.46 oz), handle assembly 1000 g (35.27 oz), escape release 500 g (17.64 oz)
Materials	Glass fiber reinforced plastic, nickel-plated die-cast zinc, anodized aluminum handle, stainless-steel hardware

Product Selection

Table 169 - Handle Assembly and Mounting Plate

	Type	Cat. No.
	Right handle ⁽¹⁾	442G-MABH-R
	Left handle ⁽¹⁾	442G-MABH-L
	Handle mounting plate (required)	442G-MABAMPH
	Lock module mounting plate (required)	442G-MABAMPL

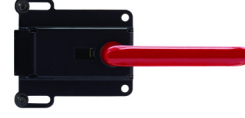

(1) Sold separately.

Table 170 - Optional Escape Release ⁽¹⁾

	Type	Cat. No.
	Escape release assembly with standard actuation shaft	442G-MABE1

(1) The standard shaft 115 mm (4.53 in.) is optimized for use on 40 mm (1.57 in.) and 45 mm (1.77 in.) profiles. An extended shaft is available for profiles larger than 45 mm (1.77 in.) (or when used with mounting plates on a 45 mm (1.77 in.) profile).

Table 171 - Accessories

	Type	Cat. No.
	Escape release extended shaft 250 mm (9.84 in.)	442G-MABASHFT
	Escape release mounting plate	442G-MABAMPE
	19-pin M23 2 m (6.6 ft) cordset	889M-F19RM-2 ⁽¹⁾





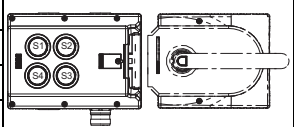
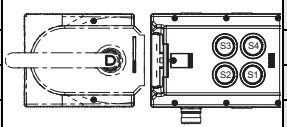

(1) Other cordset lengths are available at <https://www.rockwellautomation.com/en-us/products/hardware/allen-bradley/connection-devices/cables-and-cordsets/m23.html>.

Table 172 - Lock Module

Guard Type	Connector		Right-hand Guards Cat. No. ⁽¹⁾		Left-hand Guards Cat. No. ⁽¹⁾
Power to Release	M23 (19-pin)		442G-MABR-URM-x		442G-MABR-ULM-x
	M20 cable entry		442G-MABR-UT-x		442G-MABR-UT-x
Power to Lock	M23 (19-pin)		442G-MABL-URM-x		442G-MABL-ULM-x
	M20 cable entry		442G-MABL-UT-x		442G-MABL-UT-x

(1) x = cover control code (C00...C04). See [Table 173 on page 144](#).

Table 173 - Cover Control ⁽¹⁾

Description		Cover Control Code
Blank cover		C00
One illuminated push button		C01
Two illuminated push buttons		C02
E-stop with two illuminated push buttons		C03
E-stop with three illuminated push buttons		C04
E-stop only		C05

(1) All models are supplied with a colored lens kit, including one each of blue, green, red, and yellow, and two white.

Approximate Dimensions

Dimensions are not intended to be used for installation purposes.

Figure 119 - 442G-MAB [mm (in.)]

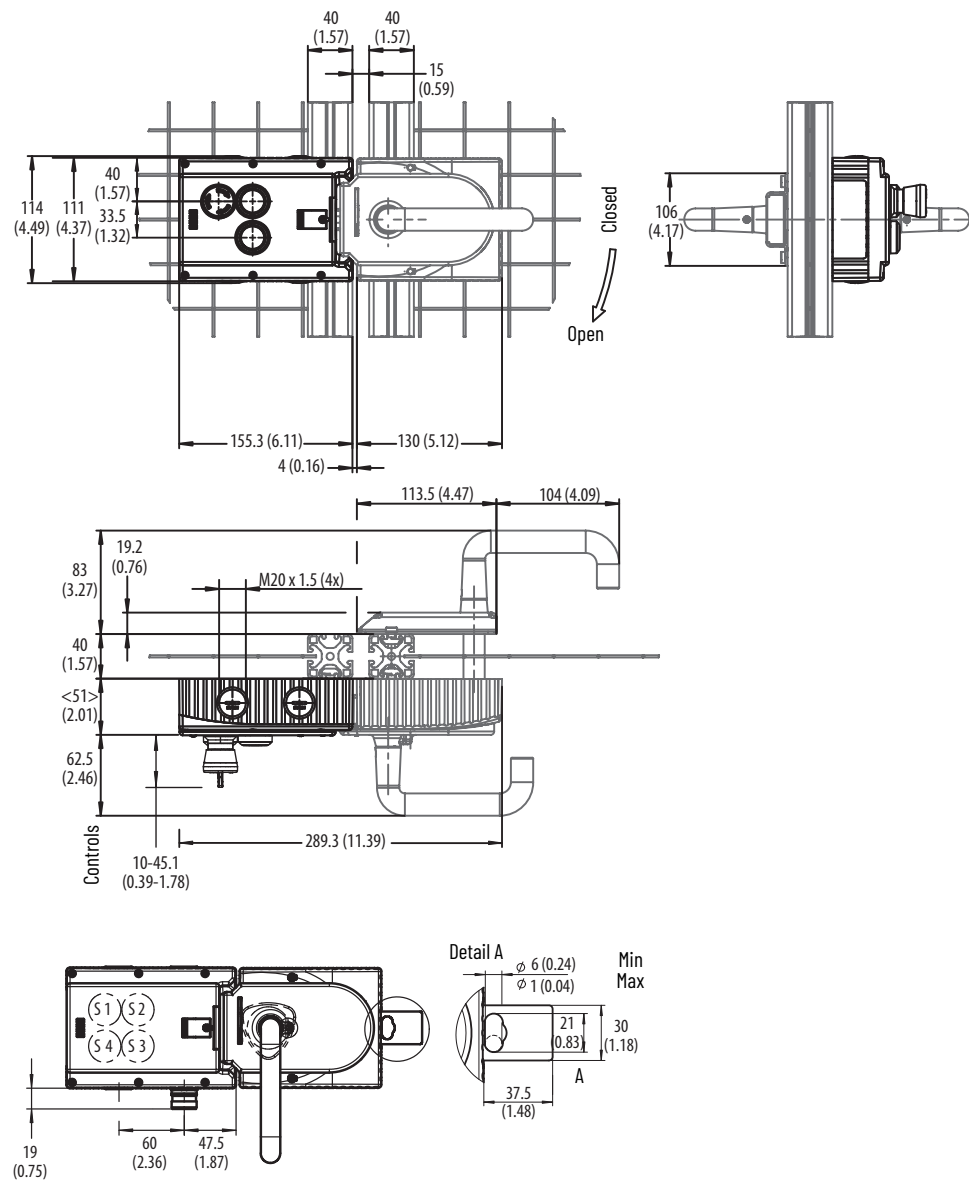

442G Multi-functional Access Box with CIP Safety

The multi-functional access boxes with CIP Safety™ have the following feature:

- EtherNet/IP™ connection saves time and money compared to wiring the standard device
- Easy integration using an Add-on Profile in Studio 5000 Logix Designer®
- Supports Device Level Ring (DLR) network topologies to help increase network resiliency ^(a)
- Rated PLe, Cat 4 for interlocking, guard lock monitoring and control of guard locking
- Unique RFID coded bolt actuator achieves the highest level of tamper-resistance in accordance with ISO 14119
- High holding force 2000 N (Fzh per ISO 14119) is suitable for a wide range of guarding applications
- Two models available: Power to Release and Power to Lock
- Versions available with an integrated emergency stop push button and connector for attaching an enabling switch
- Integrated push buttons for reset, request to unlock, start/stop
- Four status indicators for local status and diagnostics
- Optional escape release allows a person who is locked inside the safeguarded area to exit quickly and easily
- Two integrated hasps included to affix padlocks

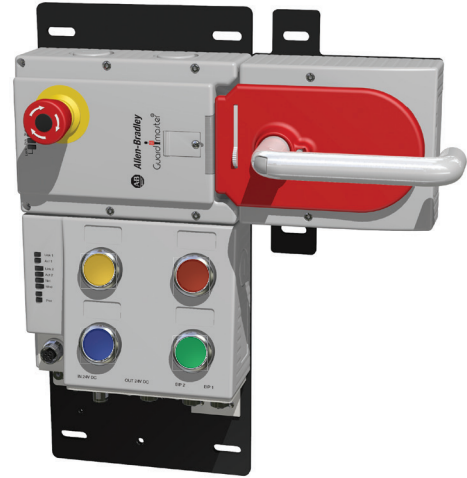

Specifications

Table 174 - Access Box Specifications

Attribute	Value		
Standards	IEC 60947-5-3, EN ISO 13849-1, ISO 14119, UL 508 (evaluated for risks of electrical shock and fire; only suitable for NFPA 79 applications)		
Safety classification	Type 4 interlocking module with guard locking and high-coded RFID actuators according to ISO 14119		
Functional safety data	PLe, Cat. 4 (according to ISO 13849-1, SIL CL 3 according to IEC 62061 and IEC 61508)		
	MTTF _d	Monitoring of guard locking	746 years
		Control of guard locking	475 years
		Evaluation of emergency stop	787 years
		Evaluation of enabling switch	753 years
	PFH	Monitoring of guard locking	3.37 x 10 ⁻⁹
		Control of guard locking	4.91 x 10 ⁻⁹
		Evaluation of emergency stop	3.05 x 10 ⁻⁹
		Evaluation of enabling switch	3.05 x 10 ⁻⁹
	B10 _d	Emergency stop	1.0 x 10 ⁵
Enabling switch		According to manufacturer specifications	
Mission time	20 years		
Certifications	cULus Listed (UL 508), CE Marked for all applicable EU directives, and UKCA Marked for all applicable regulations		
Safety outputs	CIP Safety		
Torque settings, max	<ul style="list-style-type: none"> • 1 N•m (8.85 lb•in) lock module cover screws (6x) • 0.5 N•m (4.42 lb•in) manual release locking screw • 2 N•m (17.70 lb•in) handle set screw (handle and escape release) 		
Holding force Fzh (ISO 14119)	2000 N		
Locking bolt alignment tolerance	Horizontal: ± 4 mm (0.16 in.); Vertical: ± 5 mm (0.2 in.)		
Operating voltage	Class 2 PELV 24V DC +10/-15% required ⁽¹⁾		
EMC protection requirements	In accordance with EN 61000-4 and DIN EN 61326-3-1		
Current consumption, max	500 mA		
Operating current, max	4 A		
External fuse	1 A (min), slow-blow		

(a) The multi-functional access box currently does not support CIP Sync™, including CIP Motion™ applications. It must not be connected to a DLR network that contains multi-cast I/O devices.

Table 174 - Access Box Specifications (Continued)



Attribute	Value
Risk time ⁽²⁾ (per IEC 60947-5-3)2	<ul style="list-style-type: none"> E-stop: 100 ms Enabling switch: 100 ms Guard position: 250 ms Bolt position: 250 ms Guard locking: 250 ms
Switching frequency, max	1 Hz
Insulation voltage U _i (IEC 60947-1)	75V
Impulse withstand voltage U _{imp}	0.5 kV
Pollution degree (IEC 60947-1)	3
Manual release	Built in (ISO 14119)
Mechanical life	1,000,000 operations
Ambient temperature at UB = DC 24V	-20...+55 °C (-4...+131 °F)
Storage temperature	-20...+65 °C (-4...+149 °F)
Enclosure rating	IP54
Operating humidity	5...80% relative
Vibration/shock	IEC 60068-2-27 30 g, 11 ms/IEC 60068-2-6 10...55 Hz
Weight	<ul style="list-style-type: none"> Lock/bus assembly on mounting plate: 3.6 kg (7.9 lb) Handle assembly on mounting plate: 1.2 kg (2.6 lb) Escape release: 500 g (17.6 oz)
Materials	<ul style="list-style-type: none"> Glass fiber reinforced plastic Nickel-plated die-cast zinc Anodized aluminum handle Stainless steel Powder-coated sheet steel

(1) See publication [442G-IN004](#).

(2) The risk time is the maximum difference between the time the input status changes and the time the corresponding bit in the input assembly is turned on.

Product Selection

Table 175 - Handle Assembly and Mounting Plate

	Type	Cat. No.
	Right handle ⁽¹⁾	442G-MABH-R
	Left handle ⁽¹⁾	442G-MABH-L
	Handle mounting plate (required)	442G-MABAMPH

(1) Sold separately.

Table 176 - Optional Escape Release ⁽¹⁾

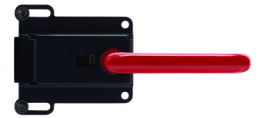
	Type	Cat. No.
	Escape release assembly with standard actuation shaft	442G-MABE1

(1) The standard shaft 115 mm (4.53 in.) is optimized for use on 40 mm (1.57 in.) and 45 mm (1.77 in.) profiles. An extended shaft is available for profiles larger than 45 mm (1.77 in.) (or when used with mounting plates on a 45 mm (1.77 in.) profile).

Table 177 - Access Box Accessories



	Type	Cat. No.
	Escape release extended shaft 250 mm (9.84 in.)	442G-MABASHFT
	Escape release mounting plate	442G-MABAMPE

Table 178 - Lock/bus Module ⁽¹⁾

Controls	Guard Type		Right-hand Guards Cat. No.		Left-hand Guards Cat. No.
Two push buttons	Power to Release		442G-MABRB-UR-P49		442G-MABRB-UL-P49
	Power to Lock		442G-MABLB-UR-P49		442G-MABLB-UL-P49
E-stop, two push buttons	Power to Release		442G-MABRB-UR-EOP49		442G-MABRB-UL-EOP49
	Power to Lock		442G-MABLB-UR-EOP49		442G-MABLB-UL-EOP49
E-stop, four push buttons, enabling switch connector	Power to Release		442G-MABRB-UR-EQJP4679		442G-MABRB-UL-EQJP4679
	Power to Lock		442G-MABLB-UR-EQJP4679		442G-MABLB-UL-EQJP4679

(1) All models are supplied with a colored lens kit, including one each of blue, green, red, and yellow, and two white.

Approximate Dimensions

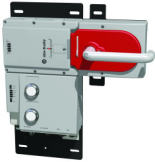
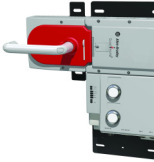
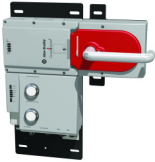
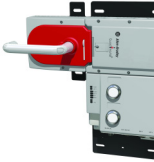
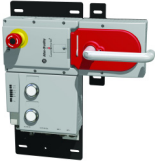
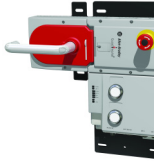
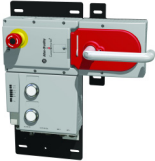
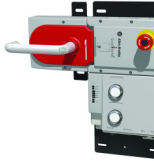
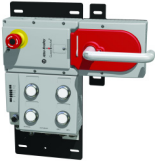
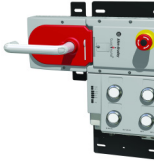
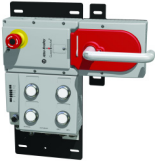
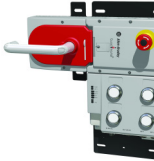
Dimensions are not intended to be used for installation purposes.

Figure 120 - 442G-MAB [mm (in.)]

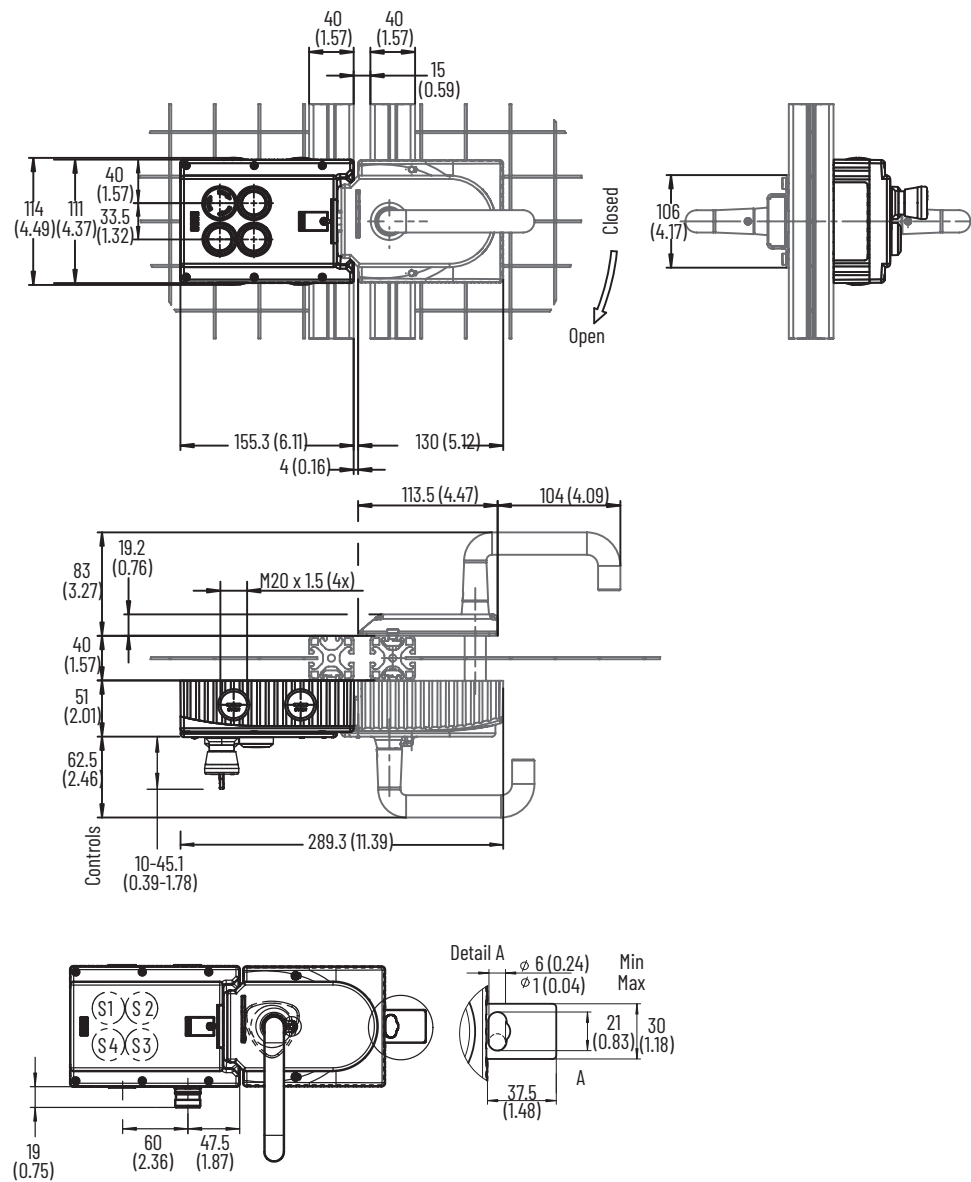

Notes:

Additional Resources

These documents contain additional information concerning related products from Rockwell Automation.

Resource	Description
442G Multi-functional Access Box User Manual, publication 440G-UM001	Provides an overview and instructions to install, wire, and troubleshoot the 442G Multi-functional Access Box. It
Dynamix™ 1443 Series Sensors Product Information, publication 1443-PC001	Included with hazardous area rated sensors, provides basic environmental, ratings, and mounting information.
Dynamix 1443 Series Sensors User Manual, publication 1443-UM001	Provides complete information for mounting and cabling 1443 Series sensors.
Cordsets and Field Attachables Technical Data, publication 889-TD002	Provides an overview of cordsets and field attachables that Rockwell Automation provides.
Industrial Automation Wiring and Grounding Guidelines, publication 1770-4.1	Provides general guidelines for installing a Rockwell Automation industrial system.
Product Certifications website, rok.auto/certifications .	Provides declarations of conformity, certificates, and other certification details.

You can view or download publications at rok.auto/literature.

Rockwell Automation Support

Use these resources to access support information.

Technical Support Center	Find help with how-to videos, FAQs, chat, user forums, and product notification updates.	rok.auto/support
Knowledgebase	Access Knowledgebase articles.	rok.auto/knowledgebase
Local Technical Support Phone Numbers	Locate the telephone number for your country.	rok.auto/phonesupport
Literature Library	Find installation instructions, manuals, brochures, and technical data publications.	rok.auto/literature
Product Compatibility and Download Center (PCDC)	Download firmware, associated files (such as AOP, EDS, and DTM), and access product release notes.	rok.auto/pcdc

Documentation Feedback

Your comments help us serve your documentation needs better. If you have any suggestions on how to improve our content, complete the form at rok.auto/docfeedback.





Allen-Bradley, ArmorBlock, Atlas, Cadet, Dynamix, Elf, expanding human possibility, Ferrogard, Guard I/O, GuardLink, Guardmaster, Prosafe, Rockwell Automation, Rotacam, SensaGuard, Sipha, Slamlock, SmartGuard, Studio 5000 Logix Designer, and Trojan are trademarks of Rockwell Automation, Inc.

CIP Motion, CIP Safety, CIP Sync, and EtherNet/IP are trademarks of ODVA, Inc.

Trademarks not belonging to Rockwell Automation are property of their respective companies.

Rockwell Automation maintains current product environmental compliance information on its website at rok.auto/pec.

Rockwell Otomasyon Ticaret A.Ş. Kar Plaza İş Merkezi E Blok Kat:6 34752, İçerenköy, İstanbul, Tel: +90 (216) 5698400 EEE Yönetmeliğine Uygundur

Connect with us.    

rockwellautomation.com ————— **expanding human possibility®**

AMERICAS: Rockwell Automation, 1201 South Second Street, Milwaukee, WI 53204-2496 USA, Tel: (1) 414.382.2000, Fax: (1) 414.382.4444

EUROPE/MIDDLE EAST/AFRICA: Rockwell Automation NV, Pegasus Park, De Kleetlaan 12a, 1831 Diegem, Belgium, Tel: (32) 2 663 0600, Fax: (32) 2 663 0640

ASIA PACIFIC: Rockwell Automation, Level 14, Core F, Cyberport 3, 100 Cyberport Road, Hong Kong, Tel: (852) 2887 4788, Fax: (852) 2508 1846

UNITED KINGDOM: Rockwell Automation Ltd. Pitfield, Kiln Farm Milton Keynes, MK11 3DR, United Kingdom, Tel: (44)(1908) 838-800, Fax: (44)(1908) 261-917

Publication SWITCH-TD001D-EN-P - October 2022

Supersedes Publication SWITCH-TD001C-EN-P - December 2021

Copyright © 2022 Rockwell Automation, Inc. All rights reserved. Printed in the U.S.A.