

MicroLogix 1762-IQ32T DC Input Module

Catalog Number 1762-IQ32T

http://literature.rockwellautomation.com/idc/groups/literature/documents/in/1762-in019_-mu-p.pdf

FR

Cette publication est disponible en français sous forme électronique (fichier PDF). Pour la télécharger, rendez-vous sur la page Internet indiquée ci-dessus.

IT

Questa pubblicazione è disponibile in Italiano in formato PDF. Per scaricarla collegarsi al sito Web indicato sopra.

DE

Diese Publikation ist als PDF auf Deutsch verfügbar. Gehen Sie auf die oben genannte Web-Adresse, um nach der Publikation zu suchen und sie herunterzuladen.

ES

Esta publicación está disponible en español como PDF. Diríjase a la dirección web indicada arriba para buscar y descarga esta publicación.

PT

Esta publicação está disponível em português como PDF. Vá ao endereço web que aparece acima para encontrar e fazer download da publicação.

MicroLogix 1762-IQ32T DC Input Module

Catalog Number 1762-IQ32T

Topic	Page
Important User Information	4
North American Hazardous Location Approval	6
Additional Resources	7
Overview	8
Module Description	9
Mount the Module	10
Field Wiring Connections	13
Wiring Options for the I/O Module	15
Labeling for the 1492 Interface Module	16
Assemble the Wire Contacts	17
Specifications	19

Important User Information

Solid state equipment has operational characteristics differing from those of electromechanical equipment. Safety Guidelines for the Application, Installation and Maintenance of Solid State Controls (Publication SGI-1.1 available from your local Rockwell Automation sales office or online at <http://literature.rockwellautomation.com>) describes some important differences between solid state equipment and hard-wired electromechanical devices. Because of this difference, and also because of the wide variety of uses for solid state equipment, all persons responsible for applying this equipment must satisfy themselves that each intended application of this equipment is acceptable.





In no event will Rockwell Automation, Inc. be responsible or liable for indirect or consequential damages resulting from the use or application of this equipment.

The examples and diagrams in this manual are included solely for illustrative purposes. Because of the many variables and requirements associated with any particular installation, Rockwell Automation, Inc. cannot assume responsibility or liability for actual use based on the examples and diagrams.

No patent liability is assumed by Rockwell Automation, Inc. with respect to use of information, circuits, equipment, or software described in this manual.

Reproduction of the contents of this manual, in whole or in part, without written permission of Rockwell Automation, Inc., is prohibited.

Throughout this manual, when necessary, we use notes to make you aware of safety considerations.

<p>WARNING</p> 	<p>Identifies information about practices or circumstances that can cause an explosion in a hazardous environment, which may lead to personal injury or death, property damage, or economic loss.</p>
<p>IMPORTANT</p>	<p>Identifies information that is critical for successful application and understanding of the product.</p>
<p>ATTENTION</p> 	<p>Identifies information about practices or circumstances that can lead to personal injury or death, property damage, or economic loss. Attentions help you identify a hazard, avoid a hazard and recognize the consequences.</p>
<p>SHOCK HAZARD</p> 	<p>Labels may be on or inside the equipment (for example, drive or motor) to alert people that dangerous voltage may be present.</p>
<p>BURN HAZARD</p> 	<p>Labels may be on or inside the equipment (for example, drive or motor) to alert people that surfaces may reach dangerous temperatures.</p>

Environment and Enclosure

ATTENTION

This equipment is intended for use in a Pollution Degree 2 industrial environment, in overvoltage Category II applications (as defined in IEC 60664-1), at altitudes up to 2000 m (6562 ft) without derating. This equipment is considered Group 1, Class A industrial equipment according to IEC/CISPR 11. Without appropriate precautions, there may be difficulties with electromagnetic compatibility in residential and other environments due to conducted and radiated disturbances.

This equipment is supplied as open-type equipment. It must be mounted within an enclosure that is suitably designed for those specific environmental conditions that will be present and appropriately designed to prevent personal injury resulting from accessibility to live parts. The enclosure must have suitable flame-retardant properties to prevent or minimize the spread of flame, complying with a flame spread rating of 5VA, V2, V1, V0 (or equivalent) if non-metallic. The interior of the enclosure must be accessible only by the use of a tool. Subsequent sections of this publication may contain additional information regarding specific enclosure type ratings that are required to comply with certain product safety certifications.

In addition to this publication, see:

- Industrial Automation Wiring and Grounding Guidelines, for additional installation requirements, Allen-Bradley publication [1770-4.1](#).
- NEMA Standards 250 and IEC 60529, as applicable, for explanations of the degrees of protection provided by different types of enclosure.

Preventing Electrostatic Discharge



ATTENTION

This equipment is sensitive to electrostatic discharge, which can cause internal damage and affect normal operation. Follow these guidelines when you handle this equipment:

- Touch a grounded object to discharge potential static.
- Wear an approved grounding wriststrap.
- Do not touch connectors or pins on component boards.
- Do not touch circuit components inside the equipment.
- Use a static-safe workstation, if available.
- Store the equipment in appropriate static-safe packaging when not in use.

North American Hazardous Location Approval

The following modules are North American Hazardous Location approved: 1762-IQ32T

<p>The following information applies when operating this equipment in hazardous locations:</p>	<p>Informations sur l'utilisation de cet équipement en environnements dangereux:</p>
<p>Products marked "CL I, DIV 2, GP A, B, C, D" are suitable for use in Class I Division 2 Groups A, B, C, D, Hazardous Locations and nonhazardous locations only. Each product is supplied with markings on the rating nameplate indicating the hazardous location temperature code. When combining products within a system, the most adverse temperature code (lowest "T" number) may be used to help determine the overall temperature code of the system. Combinations of equipment in your system are subject to investigation by the local Authority Having Jurisdiction at the time of installation.</p>	<p>Les produits marqués "CL I, DIV 2, GP A, B, C, D" ne conviennent qu'à une utilisation en environnements de Classe I Division 2 Groupes A, B, C, D dangereux et non dangereux. Chaque produit est livré avec des marquages sur sa plaque d'identification qui indiquent le code de température pour les environnements dangereux. Lorsque plusieurs produits sont combinés dans un système, le code de température le plus défavorable (code de température le plus faible) peut être utilisé pour déterminer le code de température global du système. Les combinaisons d'équipements dans le système sont sujettes à inspection par les autorités locales qualifiées au moment de l'installation.</p>
<p>WARNING</p> 	<p>EXPLOSION HAZARD</p> <ul style="list-style-type: none"> Do not disconnect equipment unless power has been removed or the area is known to be nonhazardous. Do not disconnect connections to this equipment unless power has been removed or the area is known to be nonhazardous. Secure any external connections that mate to this equipment by using screws, sliding latches, threaded connectors, or other means provided with this product. Substitution of components may impair suitability for Class I, Division 2. If this product contains batteries, they must only be changed in an area known to be nonhazardous.
<p>AVERTISSEMENT</p> 	<p>RISQUE D'EXPLOSION</p> <ul style="list-style-type: none"> Couper le courant ou s'assurer que l'environnement est classé non dangereux avant de débrancher l'équipement. Couper le courant ou s'assurer que l'environnement est classé non dangereux avant de débrancher les connecteurs. Fixer tous les connecteurs externes reliés à cet équipement à l'aide de vis, loquets coulissants, connecteurs filetés ou autres moyens fournis avec ce produit. La substitution de composants peut rendre cet équipement inadapté à une utilisation en environnement de Classe I, Division 2. S'assurer que l'environnement est classé non dangereux avant de changer les piles.

Additional Resources

Resource	Description
MicroLogix 1100 Programmable Controllers User Manual, publication 1763-UM001	A more detailed description of how to install and use your MicroLogix 1100 programmable controller and expansion I/O system.
MicroLogix 1200 Programmable Controllers User Manual, publication 1762-UM001	A more detailed description of how to install and use your MicroLogix 1200 programmable controller and expansion I/O system.
MicroLogix 1400 Programmable Controllers User Manual, publication 1766-UM001	A more detailed description of how to install and use your MicroLogix 1400 programmable controller and expansion I/O system.
MicroLogix 1100 Programmable Controllers Installation Instructions, publication 1763-IN001	Information on installing and using the MicroLogix 1100 programmable controller.
MicroLogix 1200 Programmable Controllers Installation Instructions, publication 1762-IN006	Information on installing and using the MicroLogix 1200 programmable controller.
MicroLogix 1400 Programmable Controllers Installation Instructions, publication 1766-IN001	Information on installing and using the MicroLogix 1400 programmable controller.
Industrial Automation Wiring and Grounding Guidelines, publication 1770-4.1	More information on proper wiring and grounding techniques.

If you would like a manual, you can:

- download a free electronic version from the Internet:
<http://literature.rockwellautomation.com>
- purchase a printed manual by contacting your local Allen-Bradley distributor or Rockwell Automation representative

Overview

1762 input module is suitable for use in an industrial environment when installed in accordance with these instructions. Specifically, this equipment is intended for use in clean, dry environments (Pollution degree 2⁽¹⁾) and to circuits not exceeding Over Voltage Category II⁽²⁾ (IEC 60664-1)⁽³⁾.

Install your module using these installation instructions.

1762 Input Module

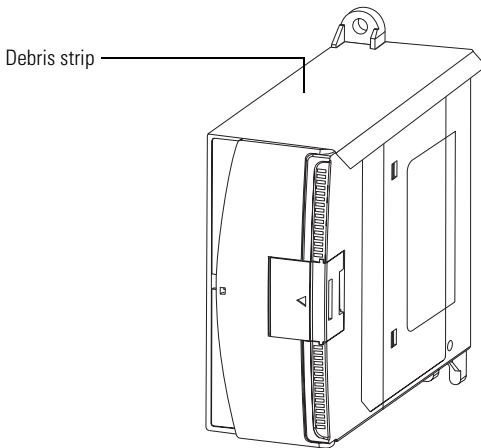

ATTENTION



Do not remove the protective debris strip until after the module and all other equipment in the panel near the module are mounted and wiring is complete. Once wiring is complete, remove protective debris strip. Failure to remove strip before operating can cause overheating.

ATTENTION



Electrostatic discharge can damage semiconductor devices inside the module. Do not touch the connector pins or other sensitive areas.

⁽¹⁾ Pollution Degree 2 is an environment where, normally, only non-conductive pollution occurs except that occasionally a temporary conductivity caused by condensation shall be expected.

⁽²⁾ Over Voltage Category II is the load level section of the electrical distribution system. At this level transient voltages are controlled and do not exceed the impulse voltage capability of the product's insulation.

⁽³⁾ Pollution Degree 2 and Over Voltage Category II are International Electrotechnical Commission (IEC) designations.

Module Description

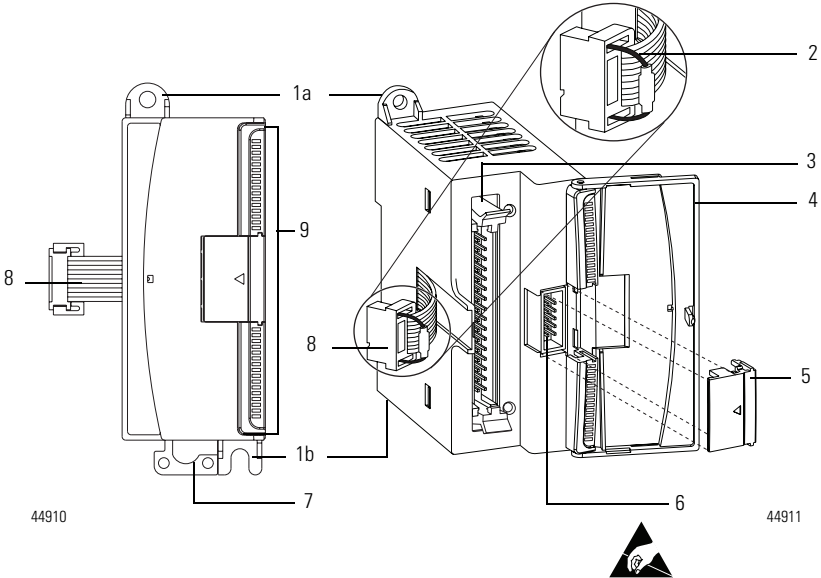

This equipment is sensitive to electrostatic discharge (ESD).
Follow ESD prevention guidelines when handling this equipment.

Front view

Left side view

	Description		Description
1a	Upper panel mounting tab	5	Bus connector cover
1b	Lower panel mounting tab	6	Bus connector with male pins
2	Pull loop	7	DIN rail latch
3	MIL-C-083503 connector	8	Flat ribbon cable with bus connector (female pins)
4	Module door with terminal identification label	9	I/O Diagnostic LEDs

ATTENTION



To comply with UL restrictions, this equipment must be powered from a source compliant with Class 2 or Limited Voltage/Current.

Mount the Module

General Considerations

Most applications require installation in an industrial enclosure to reduce the effects of electrical interference and environmental exposure. Locate your controller as far as possible from power lines, load lines, and other sources of electrical noise such as hard-contact switches, relays, and AC motor drives. For more information on proper grounding guidelines, see the Industrial Automation Wiring and Grounding Guidelines, publication [1770-4.1](#).

ATTENTION



This product is intended to be mounted to a well-grounded mounting surface such as a metal panel. Additional grounding connections from the power supply's mounting tabs or DIN rail (if used) are not required unless the mounting surface cannot be grounded. Refer to Industrial Automation Wiring and Grounding Guidelines, Allen-Bradley publication [1770-4.1](#), for additional information.

Mounting Dimensions

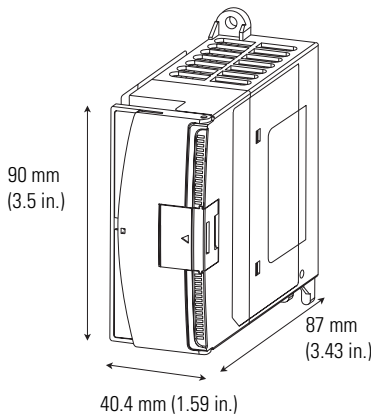

44912

Measurements do not include mounting feet or DIN rail latches.

Module Spacing

Maintain spacing from objects such as enclosure walls, wireways and adjacent equipment. Allow 50.8 mm (2 in.) of space on all sides for adequate ventilation, as shown:

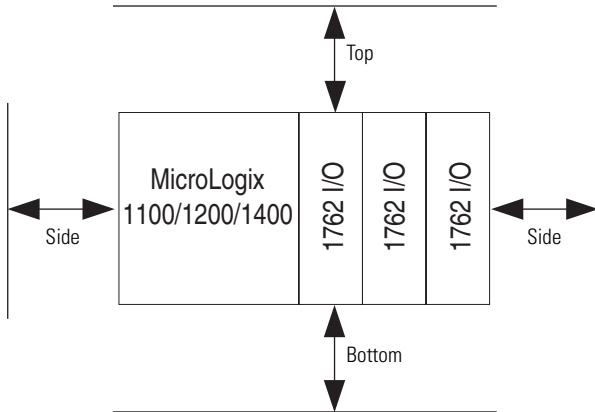

44913

DIN Rail Mounting

The module can be mounted using the following DIN rails: 35 x 7.5 mm (EN 50 022 - 35 x 7.5) or 35 x 15 mm (EN 50 022 - 35 x 15).

Before mounting the module on a DIN rail, close the DIN rail latch. Press the DIN rail mounting area of the module against the DIN rail. The latch will momentarily open and lock into place.

Use DIN rail end anchors (Allen-Bradley part number 1492-EA35 or 1492-EAH35) for vibration or shock environments.

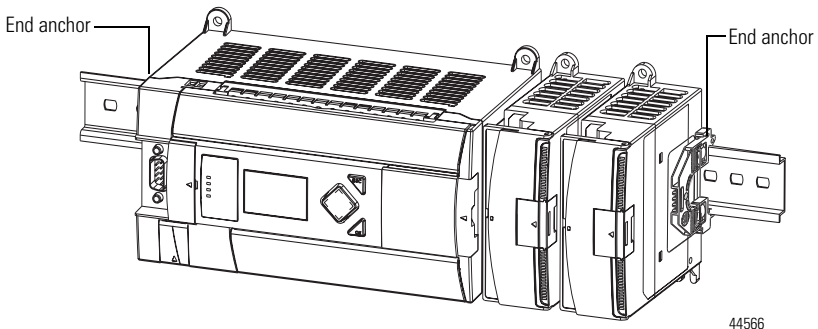

44566

TIP

For environments with greater vibration and shock concerns, use the panel mounting method described below, instead of DIN rail mounting.

Panel Mounting

Use the dimensional template shown below to mount the module. The preferred mounting method is to use two M4 (#8) panhead screws per module. M3.5 (#6) panhead screws may also be used, but a washer may be needed to ensure a good mechanical contact. Mounting screws are required on every module.

For more than 2 I/O modules: measure (number of modules - 1) x 40 mm (1.59 in.)

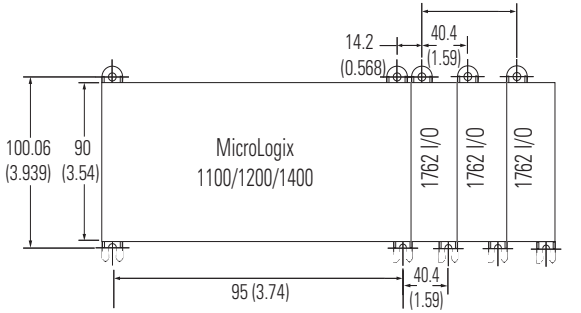

44914

NOTE: All dimensions are in mm (in.). Hole spacing tolerance: ± 0.4 mm (0.016 in.).

System Assembly

The expansion I/O module is attached to the controller or another I/O module by means of a flat ribbon cable *after* mounting as shown below.

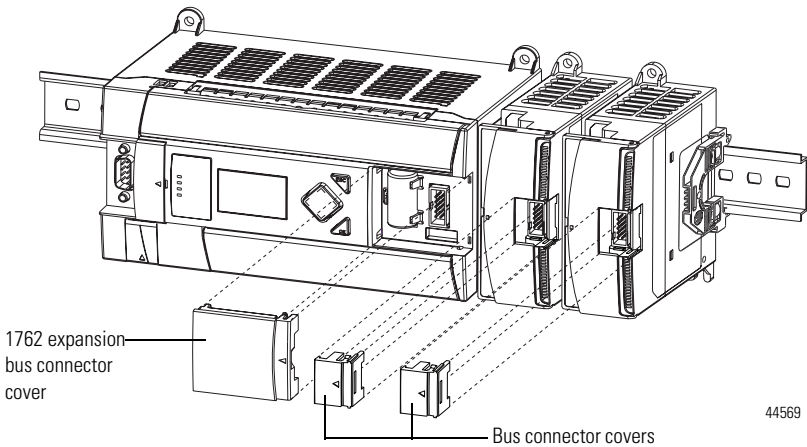

44569

TIP

Use the pull loop on the connector to disconnect modules. Do not pull on the ribbon cable.

Field Wiring Connections

Grounding the Module

In solid-state control systems, grounding and wire routing helps limit the effects of noise due to electromagnetic interference (EMI). Run the ground connection from the ground screw of the controller to the ground bus prior to connecting any devices. Use AWG #14 wire. For AC-powered controllers, this connection must be made for safety purposes.

You must also provide an acceptable grounding path for each device in your application. For more information on proper grounding guidelines, refer to the Industrial Automation Wiring and Grounding Guidelines, publication [1770-4.1](#).

WARNING**EXPLOSION HAZARD**

- In Class I, Division 2 applications, the bus connector must be fully seated and the bus connector cover must be snapped in place.
 - In Class I, Division 2 applications, all modules must be mounted in direct contact with each other as shown on page 12. If DIN rail mounting is used, an end anchor must be installed ahead of the controller and after the last 1762 I/O module.
-
-

ATTENTION

To comply with the CE Low Voltage Directive (LVD), all connected I/O must be powered from a source compliant with the Safety Extra Low Voltage (SELV) or Protected Extra Low Voltage (PELV).

WARNING

If you connect or disconnect wiring while the field-side power is on, an electrical arc can occur. This could cause an explosion in hazardous location installations. Be sure that power is removed or the area is nonhazardous before proceeding.

Input Wiring

Basic wiring of input devices to the 1762-IQ32T is shown below.

Basic Input Wiring to the 1762-IQ32T Module

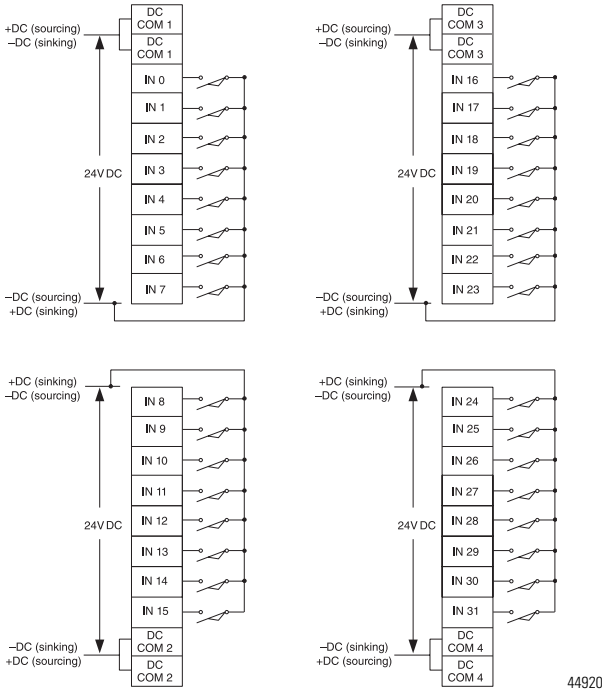

Simplified Input Circuit Diagram

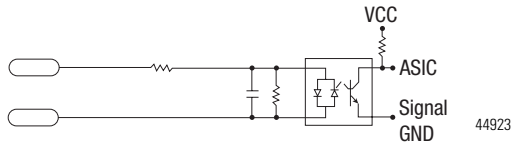

A write-on label is provided with the module. Mark the identification of each terminal with permanent ink, and slide the label back into the door.

ATTENTION



Sinking/Sourcing Inputs - Sourcing/sinking describes the current flow between the I/O module and the field device. Sourcing I/O circuits supply (source) current to sinking field devices. Sinking I/O circuits are driven by a current sourcing field device. Field devices connected to the negative side (DC Common) of the field power supply are sinking field devices. Field devices connected to the positive side (+V) of the field supply are sourcing field devices.

Wiring Options for the I/O Module

Included with your 32-point input module is a keyed 40-pin female connector and crimp type pins. These components allow you to wire I/O devices to the module using a 40-conductor cable or individual wires. Refer to Assemble the Wire Contacts on page 17 for more information on connector/pin assembly instructions.

When assembled, align the female connector over the module's male header using the keying slot as a guide. Firmly lock them together with the upper and lower retaining arms.

Wire the 1746-N3 Connector

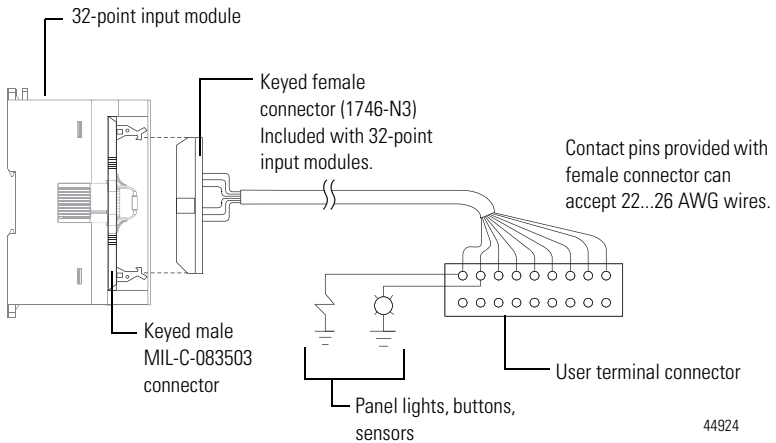

TIP

If you decide to build your cable using another 1746-N3 to terminate the cable at the 1492 Interface Module end, wire it in the following manner: Pin 1 to Pin 1, Pin 2 to Pin 2, Pin 3 to Pin 3, etc.

ATTENTION



Maximum user cable length is dependent on how much voltage drop (current x (ohms/ft.) x (feet)) the user's system can tolerate. The user's system should take into account the minimum turn-on voltage required by external loads connected to the 32-point output module, the minimum turn-on voltage required by the 32-point input module and all of the voltage drops associated with wiring to and from the load, sensors, terminal connector, power sources and the module itself.

Labeling for the 1492 Interface Module

Several different stick-on label sets are provided on a single card with 1492 Interface Modules. Each label set is identified with an I/O module catalog number and words *upper* and *lower* to identify which terminal strip the label should be affixed to.

The following table identifies the 1762-IQ32T 32-point labels and their location on the interface module. Peel off the appropriate label and apply it to the interface module.

Terminal Connector Labels

Bottom Terminal Connector	Top Terminal Connector
COM 1	COM 3
COM 1	COM 3
IN 00	IN 16
IN 01	IN 17
IN 02	IN 18
IN 03	IN 19
IN 04	IN 20
IN 05	IN 21
IN 06	IN 22
IN 07	IN 23
IN 08	IN 24
IN 09	IN 25
IN 10	IN 26
IN 11	IN 27
IN 12	IN 28
IN 13	IN 29
IN 14	IN 30
IN 15	IN 31
COM 2	COM 4
COM 2	COM 4

Assemble the Wire Contacts

- Strip the wire insulation to expose 4 mm (5/32 in.) of wire. Crimp pins can accept 22...26 AWG wire.

ATTENTION



Be careful when stripping wires. Wire fragments that fall into the module could cause damage. Once wiring is complete, be sure the module is free of all metal fragments before removing the protective debris strip. Failure to remove the strip before operating can cause overheating.

- Insert the wire into the crimp pin as far as the wire stop.

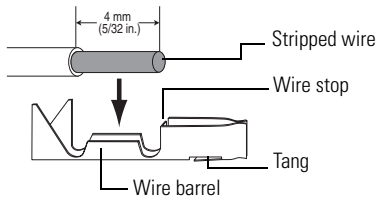

- Crimp the wire barrel around the wire using small needle nose pliers.
- Crimp the insulation barrel around the wire insulation using small needle nose pliers.

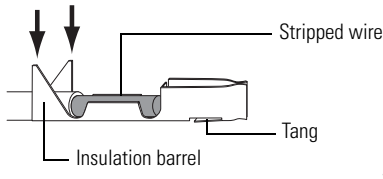

- Solder wire and wire barrel together using lead-free solder and soldering pencil.
- Insert the assembled wire contact into the terminal socket. Push the wire contact in until the tang latches. Make sure the tang is properly latched by lightly pulling on the wire.

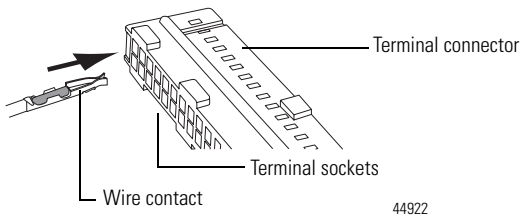

I/O Memory Mapping

For each input module, slot x, words 0...1 in the input data file contain the current state of the field input points.

Input Data File

Word	Bit Position															
	15	14	13	12	11	10	9	8	7	6	5	4	3	2	1	0
0	r	r	r	r	r	r	r	r	r	r	r	r	r	r	r	r
1	r	r	r	r	r	r	r	r	r	r	r	r	r	r	r	r

Where: r = read

1762 Expansion I/O Addressing

The addressing scheme for 1762 Expansion I/O is represented in the following figure.

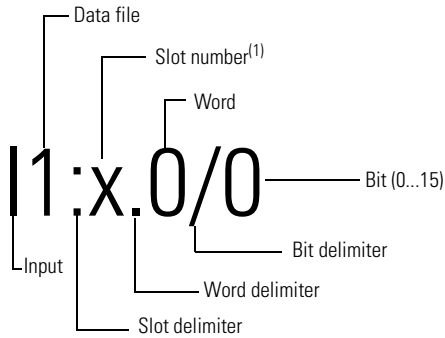

⁽¹⁾ I/O located on the controller (embedded I/O) is slot 0. I/O added to the controller (expansion I/O) begins with slot 1.

Specifications

General Specifications - 1762-IQ32T DC Input Module

Attribute	Value
Number of inputs	32
Dimensions HxWxD	90 x 40.4 x 87 mm (3.54 x 1.59 x 3.43 in.)
Shipping weight, approx.	200 g (7.05 oz)
Bus current draw, max	170 mA @ 5V DC 0 mA @ 24V DC
Heat dissipation	See Derating Charts on page 22
Wire size	22, 24, 26 AWG solid or stranded copper wire rated @ 90°C (194 °F)
Wiring category ⁽¹⁾	2 - on signal ports
Pilot duty rating	Not rated
Enclosure type rating	IP20
North American temp code	T3C

⁽¹⁾ Use this Conductor Category information for planning conductor routing. Refer to Industrial Automation Wiring and Grounding Guidelines, publication [1770-4.1](#).

Input Specifications

Attribute	Value
Isolated groups	Group 1: Inputs 0...7 Group 2 : Inputs 8...15 Group 3 : Inputs 16...23 Group 4 : Inputs 24...31
Input group to backplane isolation	Verified by one of the following dielectric tests: 1,200V AC for 2 s or 1,697V DC for 2 s 75V DC working voltage (IEC Class 2 reinforced insulation)
Vendor I.D. code	1
Product type code	7
Product code	99
Voltage category	24V DC sink/source
Operating voltage range	10...26.4V DC 10...30V DC See Derating Charts on page 22

Input Specifications

Attribute	Value
Signal delay, max	Turn-on = 8.0 ms Turn-off = 8.0 ms
On-state voltage, min	10 V DC
Off-state voltage, max	5 V DC
Off-state current, max	1.0 mA
On-state current, min	1.6 mA @ 10V DC 2 mA @ 15V DC
On-state current, max	5.7 mA @ 26.4V DC 6.5 mA @ 30.0V DC
Nominal impedance	4.7 k Ω
IEC input compatibility	Type 1

Environmental Specifications

Attribute	Value
Temperature, operating	IEC 60068-2-1 (Test Ad, Operating Cold), IEC 60068-2-2 (Test Bd, Operating Dry Heat), IEC 60068-2-14 (Test Nb, Operating Thermal Shock): -20... 60 °C (-4...140 °F) See Derating Charts on page 22
Temperature, storage	IEC 60068-2-1 (Test Ab, Unpackaged Non-operating Cold), IEC 60068-2-2 (Test Bb, Unpackaged Non-operating Dry Heat), IEC 60068-2-14 (Test Na, Unpackaged Non-operating Thermal Shock): -40...85 °C (-40...185 °F)
Relative humidity	IEC 60068-2-30 (Test Db, Unpackaged Damp Heat): 5...95% non-condensing
Vibration	IEC 60068-2-6 (Test Fc, Operating): 5 g @ 10... 500 Hz
Altitude, operating max	2000 m (6562 ft)
Shock, operating	IEC 60068-2-27 (Test Ea, Unpackaged Shock): 30 g
Shock, nonoperating	IEC 60068-2-27 (Test Ea, Unpackaged Shock): Panel mount - 50 g DIN mount - 40 g

Environmental Specifications

Attribute	Value
Emissions	CISPR 11 Group 1, Class A
ESD immunity	IEC 61000-4-2: 4 kV contact discharges 8 kV air discharges 4 kV indirect
Radiated RF immunity	IEC 61000-4-3: 10V/m with 1 kHz sine-wave 80% AM from 80...2700 MHz
EFT/B immunity	IEC 61000-4-4: ± 2 kV at 5 kHz on signal ports
Surge transient immunity	IEC 61000-4-5: ± 1 kV line-line(DM) and ± 2 kV line-earth(CM) on signal ports
Conducted RF immunity	IEC 61000-4-6: 10V rms with 1 kHz sine-wave 80% AM from 150 kHz...80 MHz

Derating Charts for each input for 1762-IQ32T Input Module

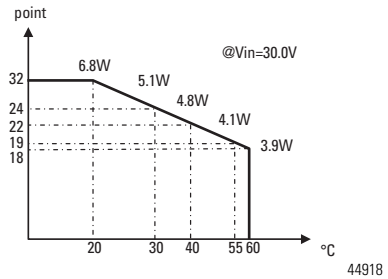
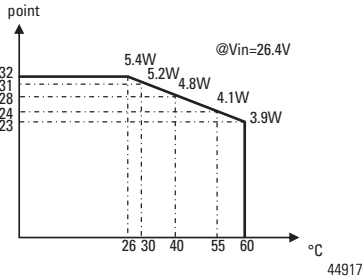

Certifications for 1762-IQ32T Input Module

Certification (when product is marked) ⁽¹⁾	Value
c-UL-us	UL Listed Industrial Control Equipment, certified for US and Canada. See UL File E65584. UL Listed for Class I, Division 2 Group A,B,C,D Hazardous Locations, certified for U.S. and Canada. See UL File E194810.
CE	European Union 2004/108/EC EMC Directive, compliant with: EN 61326-1; Meas./Control/Lab., Industrial Requirements EN 61000-6-2; Industrial Immunity EN 61000-6-4; Industrial Emissions EN 61131-2; Programmable Controllers (Clause 8, Zone A & B)
C-Tick	Australian Radiocommunications Act, compliant with: AS/NZS CISPR 11; Industrial Emissions

⁽¹⁾ See the Product Certification link at <http://www.ab.com> for Declaration of Conformity, Certificates, and other certification details.

Rockwell Automation Support

Rockwell Automation provides technical information on the Web to assist you in using its products. At <http://support.rockwellautomation.com>, you can find technical manuals, a knowledge base of FAQs, technical and application notes, sample code and links to software service packs, and a MySupport feature that you can customize to make the best use of these tools.

For an additional level of technical phone support for installation, configuration and troubleshooting, we offer TechConnect support programs. For more information, contact your local distributor or Rockwell Automation representative, or visit <http://support.rockwellautomation.com>.

Installation Assistance

If you experience a problem with a hardware module within the first 24 hours of installation, please review the information that's contained in this manual. You can also contact a special Customer Support number for initial help in getting your module up and running:

United States	1.440.646.3434 Monday – Friday, 8am – 5pm EST
Outside United States	Please contact your local Rockwell Automation representative for any technical support issues.

New Product Satisfaction Return

Rockwell Automation tests all of its products to ensure that they are fully operational when shipped from the manufacturing facility. However, if your product is not functioning and needs to be returned, follow these procedures.

United States	Contact your distributor. You must provide a Customer Support case number (see phone number above to obtain one) to your distributor in order to complete the return process.
Outside United States	Please contact your local Rockwell Automation representative for return procedure.

Allen-Bradley, Rockwell Automation, MicroLogix, and TechConnect are trademarks of Rockwell Automation, Inc. Trademarks not belonging to Rockwell Automation are property of their respective companies.

www.rockwellautomation.com

Power, Control and Information Solutions Headquarters

Americas: Rockwell Automation, 1201 South Second Street, Milwaukee, WI 53204-2496 USA, Tel: (1) 414.382.2000, Fax: (1) 414.382.4444

Europe/Middle East/Africa: Rockwell Automation, Vorstlaan/Boulevard du Souverain 36, 1170 Brussels, Belgium, Tel: (32) 2 663 0600, Fax: (32) 2 663 0640

Asia Pacific: Rockwell Automation, Level 14, Core F, Cyberport 3, 100 Cyberport Road, Hong Kong, Tel: (852) 2887 4788, Fax: (852) 2508 1846

Publication 1762-IN019A-EN-P - August 2009

PN-51822

Copyright © 2009 Rockwell Automation, Inc. All rights reserved. Printed in Malaysia.

