

FLEXIDOME HD 1080p RD

www.boschsecurity.com



BOSCH
Invented for life



HD ONVIF



- ▶ 1/2.7-inch Day/Night CMOS with progressive scan
- ▶ Choice of high performance lenses
- ▶ Local Storage for flexible recording options
- ▶ Motorized automatic back focus
- ▶ High-impact, ruggedized enclosure

FlexiDomeHD 1080p Day/Night IP cameras are progressive scan CMOS cameras that use the Bosch-designed Dinion digital imaging technology. The camera uses the latest CMOS-based HD sensor for a sharper, more detailed picture with a 16:9 image format.

Features such as multicasting, internet streaming and iSCSI recording are fully supported.

The FlexiDomeHD 1080p camera delivers the highest standards of performance and reliability in any security and surveillance scenario, day or night.

System overview

1080p HD Camera

The FlexiDomeHD camera is designed to stream a high resolution 1080p video image in true HD format (16:9). The camera now brings the unmatched Dinion Image performance to HD-standard video.

Functions

Outstanding image quality

With a 1/2.7-inch CMOS HD sensor, the FlexiDomeHD Day/Night IP camera delivers outstanding image quality. The Bosch designed digital video processing system optimally handles the HD image format without

compromise. Image performance and color reproduction are superb even under challenging lighting conditions.

Flexible lens choice

The camera comes with a choice of tele, mid-range, and ultra wide angle lenses. Each lens is specifically matched to the sensor to ensure full resolution even in the corners. The 1.8 to 3 mm optically corrected ultra wide angle lens provides outstanding performance without the need for de-warping software.

Day/Night switching

In night mode, the camera enhances low light viewing by switching the IR (infrared) filter out of the optical path and providing a monochrome image. The camera can switch from color to monochrome mode automatically by sensing the illumination level, manually via the alarm input, or remotely via a web browser.

Privacy masking

Four different privacy zones allow specific parts of a scene to be blocked. A mask for any part of the scene can be pre-programmed.

Tough design

The cast-aluminum housing, polycarbonate window, and hardened inner liner can withstand the equivalent of 55 kg (120 lbs) of force. The enclosure contains the full-featured camera and integral varifocal lens. Ideal for outdoor use, the cameras are protected against water and dust to IP 66 (NEMA -4X) standards. The camera enclosure provides the extra protection necessary for applications such as schools, banks, prisons, retail outlets and industrial buildings. Installation is quick and easy, as the camera comes completely assembled and ready to use. The camera uses Bosch designed lens and optics to deliver true HD resolution with different light levels. Using the proprietary pan/tilt/rotation mechanism, installers can select the exact field of view. Mounting options are numerous, including surface, wall, corner, and suspended ceiling mounting. The compact, sleek design and virtually flush-mount appearance complements any decor.

Efficient bandwidth and storage management

The cameras use H.264 (Main Profile) compression, bandwidth throttling, and multicasting capabilities to manage bandwidth and storage requirements efficiently, while delivering high image quality and resolution.

Bosch's innovative Quad-streaming feature enables the FlexiDomeHD to deliver three H.264 streams (a 1080p30 HD stream, a downscaled resolution stream, and a HD I-frame only stream) together with an M-JPEG stream. These four streams facilitate bandwidth-efficient viewing and recording options as well as integration with third-party video management systems.

FlexiDomeHD cameras offer unparalleled recording options. Attached to the network, they can use iSCSI targets directly without needing any recording software. The recording management capabilities of the system can be further enhanced by using the Bosch Video Recording Manager (VRM).

FlexiDomeHD supports local storage on a microSD card. This can be used for local alarm recording or for Automatic Network Replenishment (ANR) to improve the overall reliability of video recording.

Standard intelligence

With built-in video content analysis, the camera reinforces the Intelligence-at-the-Edge concept where edge devices become increasingly intelligent. The MOTION+ video motion analysis system that is built into all camera versions, is the perfect solution for applications where standard video content analysis features are required. This motion analysis algorithm is based on pixel change and includes object size filtering capabilities and sophisticated tamper-detection capabilities.

Advanced IVA version

The hardware-enhanced version of the camera upgrades the video content analysis features of the camera with the more advanced Intelligent Video Analysis (IVA). This version contains such features as idle object, line crossing, flow detection, crowd detection etc.

ONVIF conformance

The camera conforms to the ONVIF (Open Network Video Interface Forum) specification which guarantees interoperability between network video products regardless of manufacturer. ONVIF conformant devices are able to exchange live video, audio, metadata and control information. They are automatically discovered and connected to network applications such as video management systems.

Unsurpassed flexibility

There are many ways to access the camera's video: on a PC using a web browser, with the Bosch Video Management System (VMS), or with the Bosch Video Client. The bundled Bosch Video Client PC surveillance software offers a user-friendly interface to support easy installation and configuration. It also provides easy live viewing of multiple cameras, playback, forensic search and export.

Cost effective, simple installation

Three power options, PoE (Power-over-Ethernet), 24 VAC and 12 VDC are available. Using PoE makes installation easier and more cost-effective, as cameras do not require a local power source. To increase system reliability, the camera can be simultaneously connected to both PoE and 12 VDC/24 VAC supplies. Additionally, uninterruptible power supplies (UPS) can be used, which will allow continuous operation, even during a power failure.

For trouble-free network cabling, the cameras support Auto-MDIX which allows the installer to use straight or cross-over cables.

Automatic back focus

An automatic motorized back focus adjustment ensures the camera is focused accurately for both day and night operation.

Intuitive user interface

The FlexiDomeHD camera has a very intuitive user interface that allows fast and easy configuration over IP. An auto-focus lens wizard can be activated either from the PC or through the camera buttons. This makes it easy for the installer to choose the workflow that suits best for setting field-of-view and focus with 1:1 pixel mapping.

Easy Upgrade

Remotely upgrade the camera whenever new firmware becomes available. This ensures up-to-date products, thus protecting investment with little effort.

Access Security

Various security levels are available for accessing the network, the camera and the data channels. As well as password protection with three levels, 802.1x authentication using a RADIUS (Remote Authentication Dial In User Service) server is supported. To secure Web browser access, use HTTPS with a SSL certificate stored in the camera. For total data protection, the video and audio communication channels can be independently AES encrypted with 128-bit keys by installing the optional encryption site license.

Bosch Video Client surveillance software

The bundled Bosch Video Client PC surveillance software offers a user-friendly interface to support easy installation and configuration. A wizard allows the configuration of multiple cameras simultaneously using an auto detection device. Multiple cameras can be monitored in one screen and video clips on the SD card can be archived and searched in a single application.

Typical applications

- Prisons and correctional facilities
- Traffic monitoring (air, land and sea)
- Hotels, bars and nightclubs
- Commercial and government buildings
- City surveillance and safety
- Border control

Certifications and approvals

HD Standards

Complies with the SMPTE 274M-2008 Standard in:

- Resolution: 1920x1080
- Scan: Progressive
- Color representation: complies with ITU-R BT.709
- Aspect ratio: 16:9
- Frame rate: 25 and 30 frames/s

Complies with the 296M-2001 Standard in:

- Resolution: 1280x720
- Scan: Progressive
- Color representation: complies with ITU-R BT.709
- Aspect ratio: 16:9
- Frame rate: 25 and 30 frames/s

* Chapters 7 and 8 (mains voltage supply requirement) are not applicable to the camera. However, if the system in which this camera is used needs to comply with this standard, then any power supplies used must comply with this standard.

| Region | Certification |
|--------|---------------|
| Europe | CE |
| USA | UL |
| | FCC |
| Canada | CSA |

Installation/configuration notes

Ordering chart

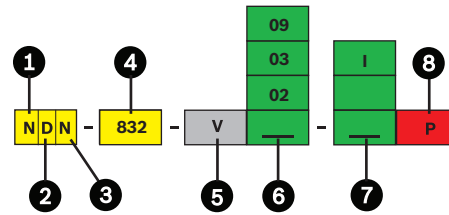

| | | | |
|---|-----------------------------|---|--|
| 1 | N: Network camera | 5 | Varifocal lens, auto iris |
| 2 | D: Dome | 6 | 02: 1.8 to 3 mm lens * 03: 3.8 to 13 mm lens 09: 9 to 40 mm lens |
| 3 | N: Day/Night | 7 | --: Motion+ I: IVA enabled |
| 4 | 832:FlexiDomeHD performance | 8 | P: PoE |

*optically corrected ultra wide angle lens

Electro Magnetic Compatibility

| | |
|-----------|---|
| Emission | EN55022 Class B FCC Part 15 Class B |
| Immunity | EN50130-4 (PoE, +12 VDC, 24 VAC)* EN50121-4 |
| Safety | EN60950-1 UL60950-1 (2nd edition) CAN/CSA-C 22.2 No. 60950-1 |
| Vibration | Camera with lens as per IEC60068-2-6 (5 m/s ² , operational) |

Dimensions

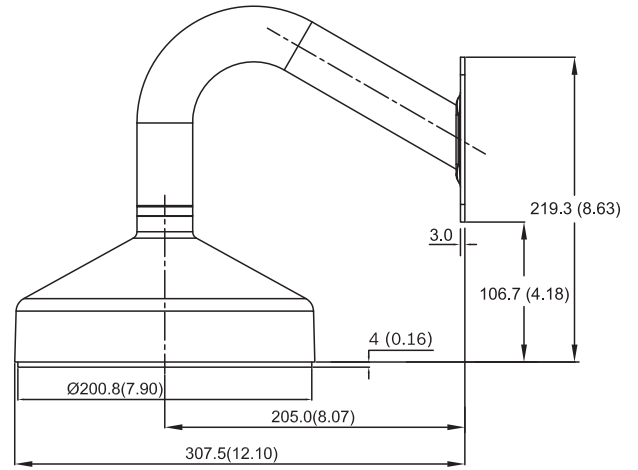
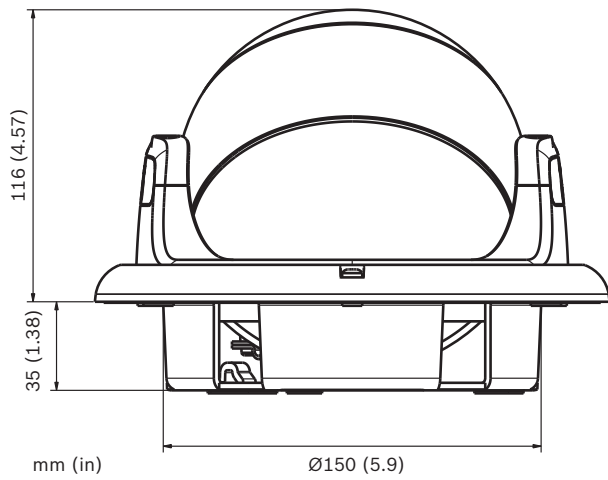
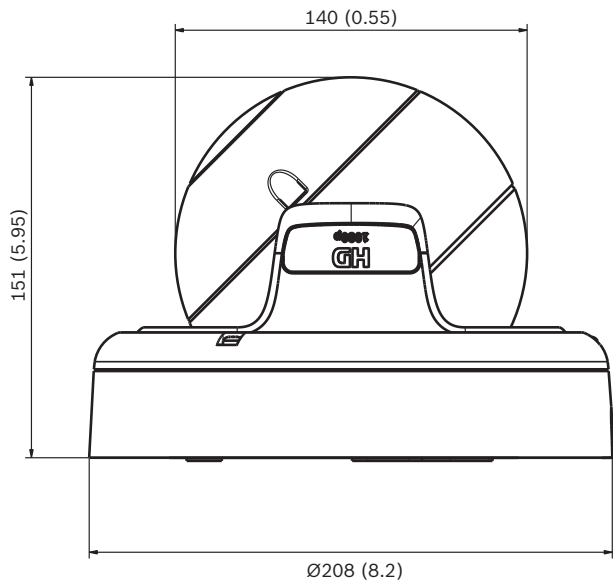

VDA-832FHD-WMT Wall mount dimensions

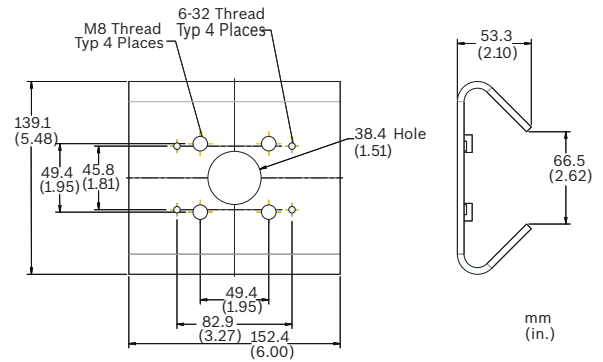

LTC 9213/01 Pole Mount Adapter dimensions

Mounting brackets (not included)

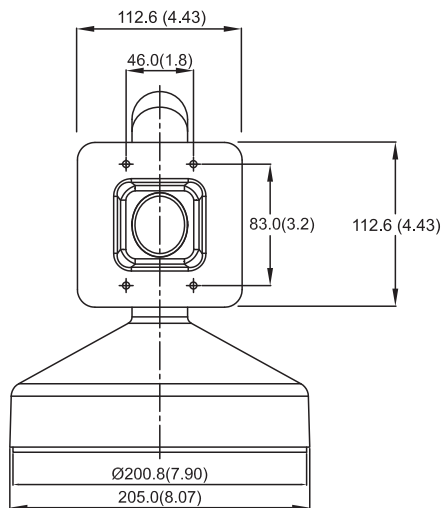

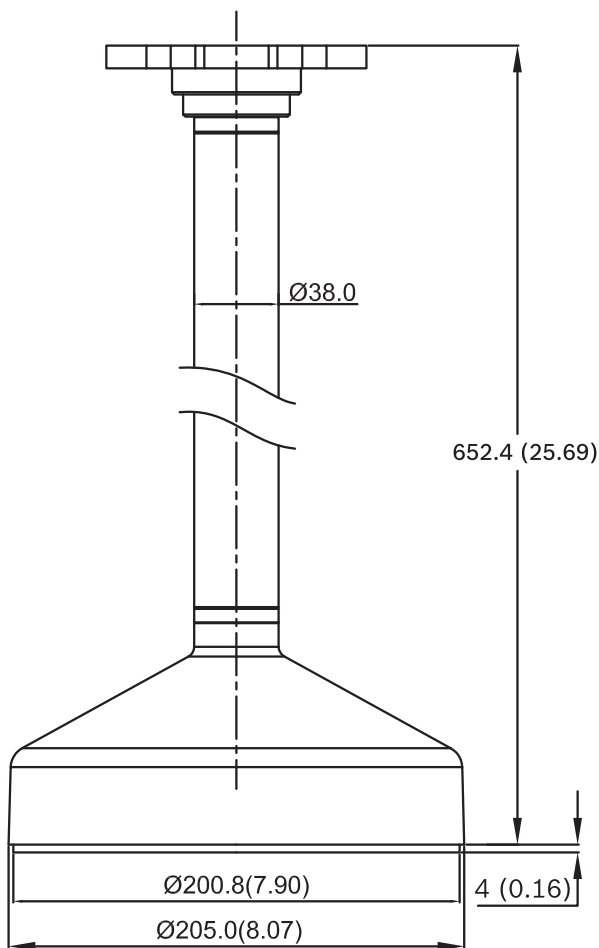
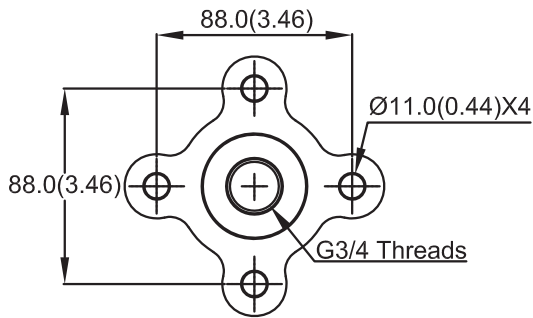

VDA-832FHD-PMT Pipe mount dimensions

Parts included

| Quantity | Components |
|----------|--|
| 1 | NDN-832 Series FlexiDomeHD Day/Night IP Camera |
| 1 | Quick Install Guide and Safety Instructions |
| 1 | Optical disk with Bosch Video Client, manuals, and system requirements |

Technical specifications

Electrical

| | |
|---------------------------------|---|
| Power Supply | 24 VAC \pm 10% 50/60 Hz 12 VDC \pm 10% Power-over-Ethernet 48 VDC nominal |
| Current Consumption | 0.8 A 1 A IVA (12 VDC) 0.7 A 0.8 A IVA (24 VAC) 0.25 A 0.3 A IVA (PoE 48 VDC) |
| Power Consumption Heater on | 9.6 W 11 W IVA (12 VDC) 13.4 W 15.8 W IVA (24 VAC) 12.2 W 13.4 W IVA (PoE 48 VDC) |
| Power Consumption Heater off | 4.8 W 6 W IVA (12 VDC) 8.4 W 10.8 W IVA (24 VAC) 7.2 W 8.4 W IVA (PoE 48 VDC) |

Sensor

| | |
|---------------|-----------------|
| Type | 1/2.7-inch CMOS |
| Active Pixels | 1920 x 1080 |

Video

| | |
|--|--|
| Video compression | H.264 (ISO/IEC 14496-10); M-JPEG, JPEG |
| Streaming | Four individually configurable streams in H.264 and M-JPEG, configurable frame rate and bandwidth. |
| Two independently configurable H.264 streams | Stream 1: H.264 Main Profile (MP) 1080p 25/30, H.264 Main Profile (MP) 720p 25/30 or H.264 MP Standard Definition (SD) Stream 2: Copy of stream 1 (when 1080p), H.264 Main Profile (MP) 720p 25/30 (when stream 1 is 720p) or H.264 MP Standard Definition (SD) |
| Two additional streams | M-JPEG stream and High Definition (HD) I-frame only stream. |
| HD Resolution (H x V) | 1080p: 1920 x 1080 720p: 1280 x 720 |
| 480p Resolution (H x V) | Encoding: 704 x 480 Displayed: 854 x 480 |
| 240p Resolution (H x V) | Encoding: 352 x 240 Displayed: 432 x 240 |
| Overall IP Delay | Min. 120 ms, Max. 240 ms |
| GOP structure | IP, IBP, IBBP |

Sensitivity (3200 K, scene reflectivity 89%, F1.2)

| | |
|------------------------------|---|
| Minimum illumination (30IRE) | Color: 0.22 lx (0.022 fc) Monochrome: 0.05 lx (0.005 fc) |
|------------------------------|---|

| | |
|------------------------|---|
| Day/Night | Color, Mono, Auto |
| White Balance | ATW (2500 to 10000K), ATWhold and manual |
| Shutter | Auto (1/50 [1/60] to 1/150000) automatic Fixed selectable |
| Backlight compensation | On/off |
| Contrast enhancement | On/off |
| Sharpness | Sharpness enhancement level selectable |
| Dynamic Range | Digital WDR: 76 dB |
| Privacy Masking | Four independent areas, fully programmable |
| Video Motion Analysis | Motion+ or IVA option |

Audio

| | |
|-----------------------|----------------------------------|
| Standard | G.711, 8kHz sampling rate AAC |
| Signal-to-noise ratio | > 50 dB |
| Audio Streaming | Full duplex / half duplex |

Input/output

| | |
|----------------------|--|
| Audio | 1 x mono line in, 1 x mono line out |
| • connector | 3.5 mm stereo jack |
| • signal line in | 12 kOhm typical, 1 Vrms max |
| • signal line out | 1 Vrms at 1.5 kOhm typical, |
| Alarm | 2 inputs |
| • activation voltage | +5 VDC to +40 VDC (+3.3 VDC with DC-coupled 22 kOhm pull-up resistor) |
| Relay | 1 output |
| • voltage | 30 VAC or +40 VDC Maximum 0.5 A continuous, 10VA |
| Data port | RS-232/422/485 |

Local Storage

| | |
|------------------|---|
| Memory card slot | Supports SDHC and SDXC microSD cards up to 2 TB |
| Recording | Continuous recording, ring recording, alarm/events/schedule recording |

Software Control

| | |
|--------------------|--|
| Unit Configuration | Via web browser or Configuration Manager |
| Software update | Flash ROM, remote programmable |

Network

| | |
|------------|--|
| Protocols | RTP, RTSP, Telnet, UDP, TCP, IP, HTTP, HTTPS, FTP, DHCP, IGMP V2/V3, ICMP, ARP, SMTP, SNTP, SNMP, 802.1x, UPnP |
| Encryption | TLS 1.0, SSL, AES (optional) |
| Ethernet | STP, 10/100 Base-T, auto-sensing, half/full duplex, RJ45 |
| PoE supply | IEEE 802.3at compliant |

Optical

| | |
|----------------------|--|
| Varifocal lens | Manual zoom and focus adjustment |
| Iris control | Automatic iris control |
| Viewing angle | |
| 1.8 to 3 mm | Wide 115 x 84° (H x V) Tele 87° x 57° (H x V) |
| 3.8 to 13 mm | Wide: 87° x 48° (H x V) Tele: 26° x 14.1° (H x V) |
| 9 to 40 mm | Wide: 37° x 20° (H x V) Tele: 8.1° x 5.1° (H x V) |

Mechanical

| | |
|--------------------|------------------------------|
| Dimensions (D x H) | 208 x 151 mm (8.2 x 5.95 in) |
| Weight | 2200 g (4.85 lb) |

Environmental

| | |
|-----------------------------|----------------------------------|
| Operating Temperature | -50°C to +55°C (-58°F to 131°F) |
| Operating Temperature (IVA) | -50°C to +50°C (-58°F to 122°F) |
| Storage Temperature | -30°C to +70°C (-22°F to +158°F) |
| Operating Humidity | 20% to 93% RH |
| Storage Humidity | up to 98% RH |
| Vandal Resistance | Ik10 |
| Ingress Resistance | IP66, NEMA 4x |

Ordering information

HD Dome 1080p

1/2.7-inch CMOS, IP Dome Camera, 1080p HD, Motion +, 1.8 -- 3 mm lens

Order number **NDN-832V02-P**

HD Dome 1080p

1/2.7-inch CMOS, IP Dome Camera, 1080p HD, IVA enabled, 1.8 -- 3 mm lens

Order number **NDN-832V02-IP**

HD Dome 1080p

1/2.7-inch CMOS, IP Dome Camera, 1080p HD, Motion +, 3.8 -- 13 mm lens

Order number **NDN-832V03-P**

HD Dome 1080p

1/2.7-inch CMOS, IP Dome Camera, 1080p HD, IVA enabled, 3.8 -- 13 mm lens

Order number **NDN-832V03-IP**

HD Dome 1080p

1/2.7-inch CMOS, IP Dome Camera, 1080p HD, Motion +, 9 -- 40 mm lens

Order number **NDN-832V09-P**

HD Dome 1080p

1/2.7-inch CMOS, IP Dome Camera, 1080p HD, IVA enabled, 9 -- 40 mm lens

Order number **NDN-832V09-IP**

Accessories

VDA-832FHD-WMT

Wall mount bracket for HD FlexiDomes

Order number **VDA-832FHD-WMT**

VDA-832FHD-PMT

Pendant pipe mount bracket for HD FlexiDomes

Order number **VDA-832FHD-PMT**

LTC 9213/01 Pole Mount Adapter

Pole mount adapter with stainless steel straps, light gray finish

Order number **LTC 9213/01**

S1460 Service/Monitor Cable

2.5 mm connector to BNC for analog and IP cameras, 1 m

Order number **S1460**

VJT-XTC XF

VideoJet XTC XF, H.264 video transcoder

Order number **VJT-XTCXF**

Represented by:

Americas:

Bosch Security Systems, Inc.
130 Perinton Parkway
Fairport, New York, 14450, USA
Phone: +1 800 289 0096
Fax: +1 585 223 9180
security.sales@us.bosch.com
www.boschsecurity.us

Europe, Middle East, Africa:

Bosch Security Systems B.V.
P.O. Box 80002
5617 BA Eindhoven, The Netherlands
Phone: + 31 40 2577 284
Fax: +31 40 2577 330
emea.securitysystems@bosch.com
www.boschsecurity.com

Asia-Pacific:

Robert Bosch (SEA) Pte Ltd, Security Systems
11 Bishan Street 21
Singapore 573943
Phone: +65 6571 2808
Fax: +65 6571 2699
apr.securitysystems@bosch.com
www.boschsecurity.asia

China:

Bosch (Shanghai) Security Systems Ltd.
201 Building, No. 333 Fuquan Road
North IBP
Changning District, Shanghai
200335 China
Phone +86 21 22181111
Fax: +86 21 22182398
www.boschsecurity.com.cn

America Latina:

Robert Bosch Ltda Security Systems Division
Via Anhanguera, Km 98
CEP 13065-900
Campinas, Sao Paulo, Brazil
Phone: +55 19 2103 2860
Fax: +55 19 2103 2862
al.securitysystems@bosch.com
www.boschsecurity.com