

Thermo-Trex® 200-HD Single Conductor Cable

- UL Recognized
- CSA
- Max Conductor Temp 200°C (392°F)
- Cold Temp Rating -60°C
- 600 V
- Zero Halogen

Thermo-Trex® 200-HD is the superior replacement for standard silicone rubber motor lead (SRML) cable. Our new and improved cable is specially designed to meet the demand for a heat resistant, flexible cable that offers better cut-through and abrasion resistance than traditional SRML products. Flexibility is achieved by using finely stranded, tinned copper conductors and a specially woven high-density fabric jacket impregnated with moisture resistant finishing compounds. High heat resistance allows the Thermo-Trex® 200-HD to withstand continuous temperatures up to 392°F (200°C). The high-density fabric jacket adds protection against cut-through and abrasion.

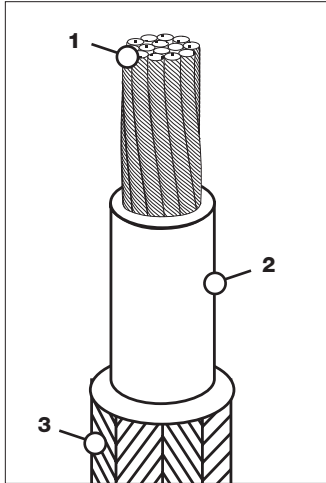

FEATURES & BENEFITS

- 1. FLEXIBLE, TINNED COPPER STRANDING** – Increased flexibility for easier installation.
- 2. SILICONE RUBBER INSULATION** – Provides resistance to heat, moisture and chemicals.
- 3. WOVEN HIGH DENSITY FABRIC JACKET** – Superior abrasion and cut-through resistance.
- 4. STAINLESS STEEL OVERBRAID** – Optional

APPLICATIONS

- Conveyors
- Generators
- Crane Hoists
- Pumps
- Kiln Fans
- Replacement for Std. SRML
- Furnaces
- Control Panels
- Motor Operated Valves

ORDERING INFORMATION (MINIMUM PURCHASE MAY BE REQUIRED IF PRODUCT NOT STOCKED)

PART NO.			AWG SIZE	CONDUCTOR STRANDING	AMPACITY ¹	NOMINAL O.D. (IN)	WT. (LBS) PER 1000'
BLACK	WHITE	RED					
441018BLK	441018WHT	441018RED	18	7/26	27	0.14	13
441016BLK	441016WHT	441016RED	16	7/24	37	0.15	16
441014BLK	441014WHT	441014RED	14	7/22	51	0.162	21
441012BLK	441012WHT	441012RED	12	19/25	66	0.182	31
441010BLK	441010WHT	441010RED	10	19/23	90	0.238	52
441008BLK	441008WHT	441008RED	8	54/25	125	0.294	85
441006BLK	441006WHT	441006RED	6	84/25	167	0.365	125
441004BLK	441004WHT	441004RED	4	133/25	226	0.399	168
441002BLK	441002WHT	441002RED	2	133/23	305	0.474	267
441001BLK	441001WHT	441001RED	1	259/25	362	0.537	321
441100BLK	441100WHT	441100RED	1/0	259/24	422	0.592	403
441200BLK	441200WHT	441200RED	2/0	259/23	492	0.638	493
441300BLK	441300WHT	441300RED	3/0	259/22	574	0.687	605
441400BLK	441400WHT	441400RED	4/0	259/21	671	0.747	745
441250BLK	441250WHT	441250RED	250	427/22	756	0.834	948
441350BLK	441350WHT	441350RED	350	427/21	947	0.944	1273
441500BLK	441500WHT	441500RED	500	427/19	1202	1.074	1722

NOTE: (1) Based on single conductor in free air, 200°C conductor temperature, 40°C ambient temperature per IEEE STD 835.

Portable Cords
 Power Cables (600 Volt to 35 kV)
 Welding Cables
 VFD/Servo Motor Cables
 Reeling Cables
 Control Cables/Instrumentation
 Bus Cables
 Flat Festoon Cables
 Retractable Coil Cables
 Chemical & Temp. Resistant Cables
 High Temperature Cables
 Igniter Cables
 Thermocouple Extension Wires
 Engineered Custom Cables