

## INSTRUCTIONS FOR USE AND MAINTENANCE FOR CONTACTORS

IEC-EN 60947-4-1  
VDE 0660

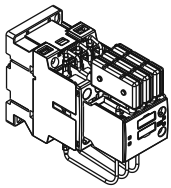

CMC 12B

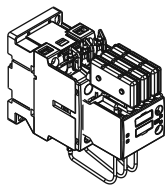

CMC 20B

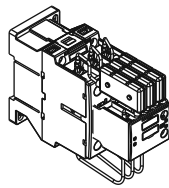

CMC 32B

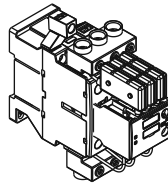

CMC 40B

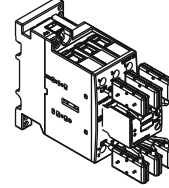

CMC 75B, CMC 85B

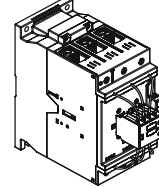

CMC 150D

### TECHNICAL DATA

The contactor conform to the recommendations IEC-EN 60947-4-1. For the rated data see the rating plate on the contactor body side.

#### WARNING:

**HAZARDOUS VOLTAGE CAN CAUSE ELECTRICAL SHOCK AND BURNS. DISCONNECT POWER BEFORE PROCEEDING WITH ANY WORK ON THIS EQUIPMENT.**



**WHEN THE SYSTEM VOLTAGE IS APPLIED AND THE LOAD IS CONNECTED, DO NOT OPERATE THE CONTACTOR BY PRESSING DOWN THE POSITION INDICATOR.**

**MANUAL OPERATION NOT PERMITTED FOR FUNCTION TESTING.**



**SWITCH ONLY ONTO DISCHARGED CAPACITORS. DO NOT REMOVE PRECHARGING RESISTORS, AS THIS WOULD CAUSE THE CONTACTS TO BE DAMAGED IN SWITCHING OPERATIONS UNDER LOAD.**

#### COIL CIRCUIT

The rated coil voltage is marked on the coil. The excitation voltage should not deviate from the value of rated voltage more than +10% or -15%. A voltage drop of more than 15% during the closing action is not permissible because it might cause burning of contactor.

#### MOUNTING

The contactors CMC 12B, CMC 20B, CMC 32B and CMC 40B have possibility of snap-on fastening to 35mm mounting rail to DIN EN 50022, or screw mounting to plane surface using two M4 screws. The contactors CMC 75B and CMC 85B have possibility of snap-on fastening to 35mm and 75mm mounting rail to DIN EN 50022, or screw mounting to plane surface using two M4 or M5 screws. The protection degree of contactors CMC 12B to CMC 150D is IP20 to IEC 60529 which mean that contactor should be mounted in dry and clean rooms. Mount the contactor on a vertical plane surface so that the terminal markings are in normal position for reading. Connect the contactor by using single wire or multi wire conductors: 1-2,5mm<sup>2</sup> single wire conductor; 0,75 - 1,5 multi wire conductor for auxiliary contacts and 1,5-6mm<sup>2</sup> for main contacts for CMC 12B; 2,5-10mm<sup>2</sup> for CMC 20B and CMC 32B; 6-25 mm<sup>2</sup> for CMC 40B; 16-35 mm<sup>2</sup> for CMC 75B and CMC 85B; 16-95 mm<sup>2</sup> for CMC 150D.

#### VERY IMPORTANT NOTE:

**For single compensation air coils or 3-phase reactors (coils with magnetic core and air gap) are not necessary. When the contactor is used for group (central) compensation we recommend to use appropriate 3-phase filter circuit reactors (coils with magnetic core and air gap). At single compensation the power of selected contactor is according to capacitors rated power. At group and central compensation the power of selected contactor has to be one step higher than capacitor's rated power (if you don't use reactors). During exploitation, current value must not exceed the declared values. Use only HRC fuses gG type for each step for short circuit protection. Use only halogen free connection wires.**

#### OPERATION

Observe operating voltage (see rating plate of magnet coil). Contact endurance: 2x10<sup>5</sup> make/break operations for CMC 12B; 1,5x10<sup>5</sup> for CMC 20B; 1x10<sup>5</sup> for CMC 32B - CMC 150D. Switching frequency: 240/h (1 make/break operation/15s) for CMC 12B. Switching frequency: 120/h (1 make/break operation/30s) for CMC 20B. Switching frequency: 100/h (1 make/break operation/30s) for CMC 32B - CMC 150D. Through the use of quick-discharge resistors, the danger of complete polarity reversal in the event of rapidly recurring closure can be excluded.



**Before switching the contactor in the circuit, The capacitor must be discharged (the voltage at the terminal must be < 50 V).**

#### MAINTENANCE

Remove dust with compressed air. Foreign bodies on the magnet pole faces causes humming. If necessary clean the pole faces carefully. Do not use a chemical substances or sharp object for cleaning. If there is still hum, replace the contactor (it has worn out).

### DIMENSION DRAWINGS (mm)

### Drilling plan (mm)

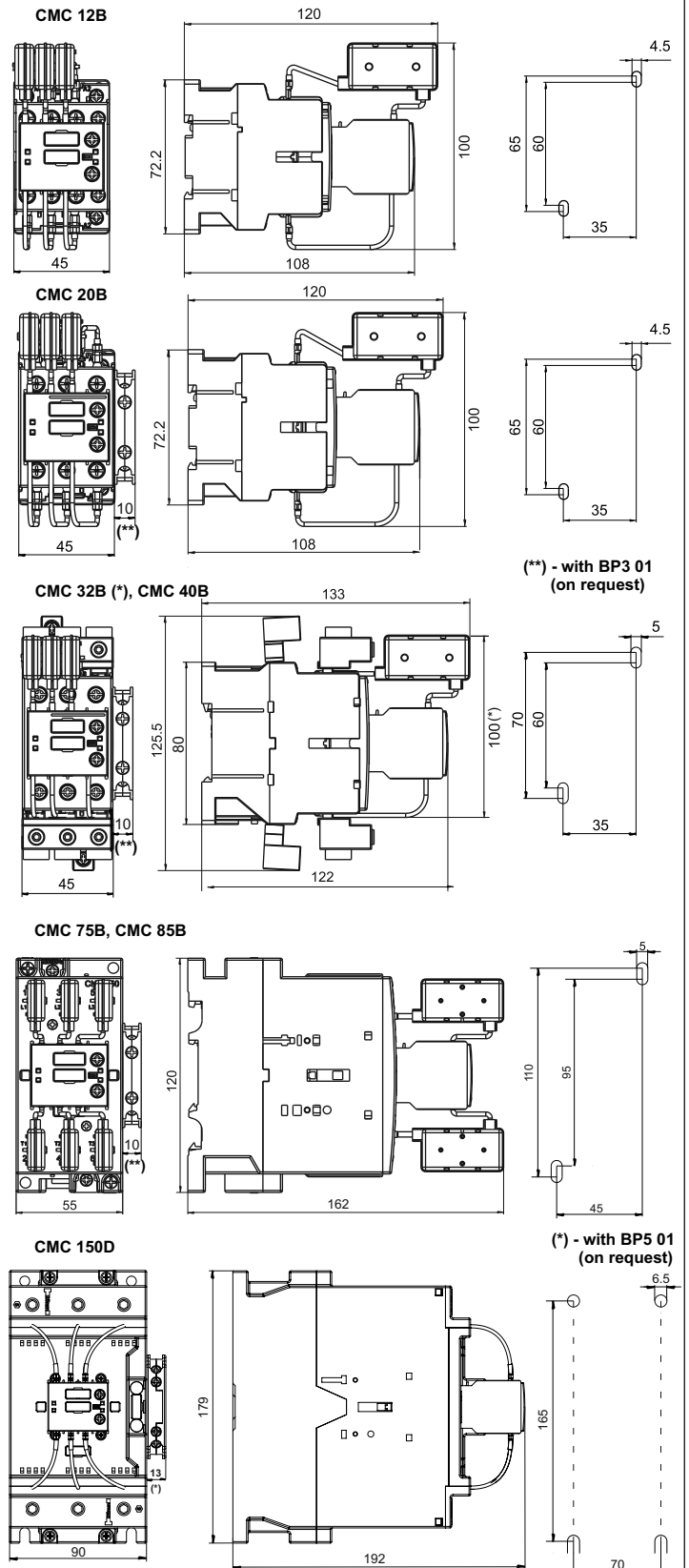

**POSSIBLE INSTALLATION POSITION**

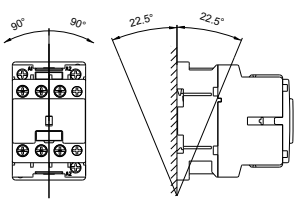

CMC 12B, CMC 20B,  
CMC 32B, CMC 40B  
CMC 75B, CMC 85B  
CMC 150D

A= 60 - CMC 12B, CMC 20B,  
CMC 32B, CMC 40B  
A= 75 - CMC 75B, CMC 85B,  
A= 110 - CMC 150D

Mounting, of a contactor, steps: A,B and C.

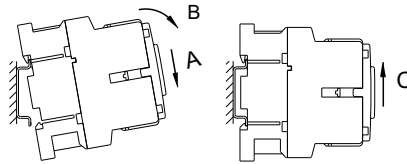

Unmounting, of a contactor, steps: 1, 2 and 3.

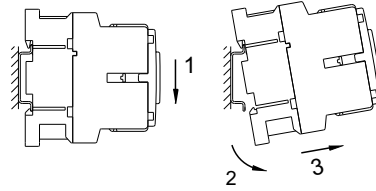

**REPLACEMENT OF THE COIL**

CMC 12B; CMC 20B;  
CMC 32B; CMC 40B;

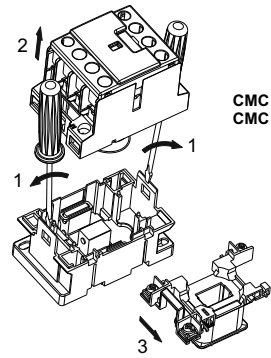

Unscrew pos.1  
Lift the upper  
part pos.2  
Replace the coil  
pos.3

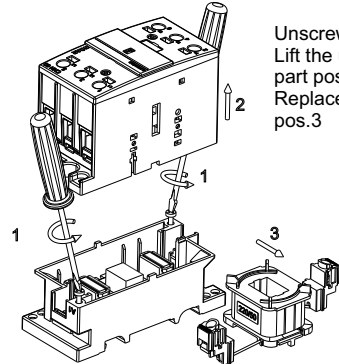

CMC 75B; CMC 85B

<p>Step 1: Loosen the four screws ~ 10mm.</p>	<p>Step 2: Separate the top case and coil from the bottom case.</p>
<p>Step 3: Disconnect the coil.</p>	<p>Step 4: Connect the two coil connectors and replace the voltage plate if necessary.</p>
<p>Step 5: Before closing the case after installing the coil over the core, insert the two coil wires in their slots.</p>	<p>Step 6: Close the bottom case with the top case and tighten the four screws.</p>

**CONTROL DIAGRAM**

With permanent button "TK"

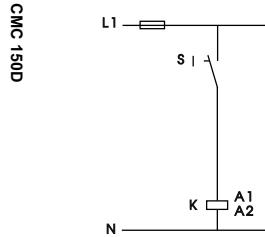

CMC 150D

**CONNECTION DIAGRAMS AND TERMINAL MARKINGS FOR SINGLE COMPENSATION**

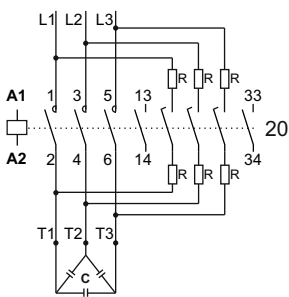

CMC 12B

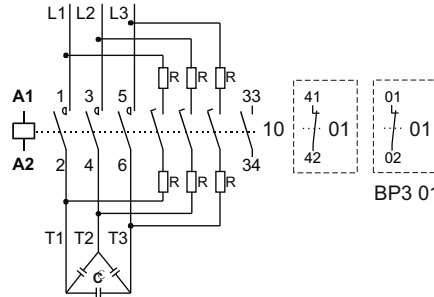

CMC 20B; CMC 32B; CMC 40B;  
CMC 75B; CMC 85B

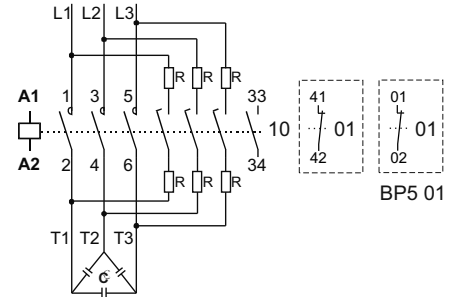

CMC 150D

**CONNECTION DIAGRAM for GROUP (CENTRAL) COMPENSATION**

380/400 V / 50Hz

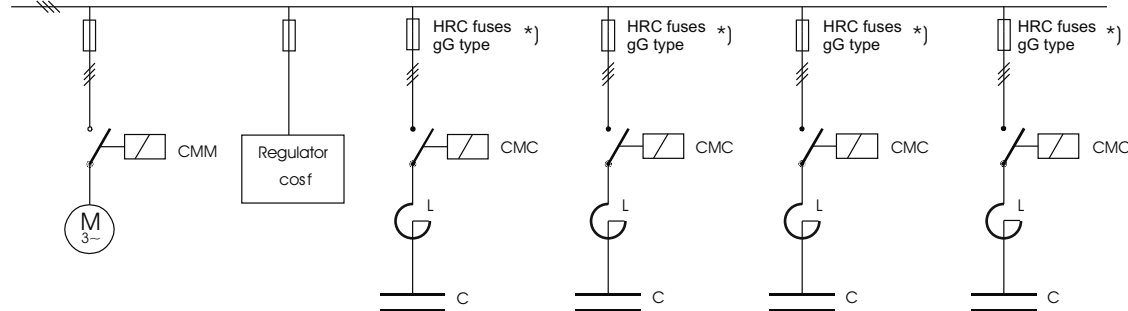

- \*)The backup fuses for each step (HRC, gG) should be scaled for 1,6 to 1,8 times of the Ie(A)/AC-6b.

**CIRCUTOR SAT: 902 449 459 (SPAIN) / (+34) 937 452 919 ( Out of Spain)**

Vial Sant Jordi, s/n  
08232 - Viladecavalls (Barcelona)  
Tel: (+34) 937 452 900 - Fax: (+34) 937 452 914  
e-mail : sat@circutor.com

**M061A01-03-23A**