

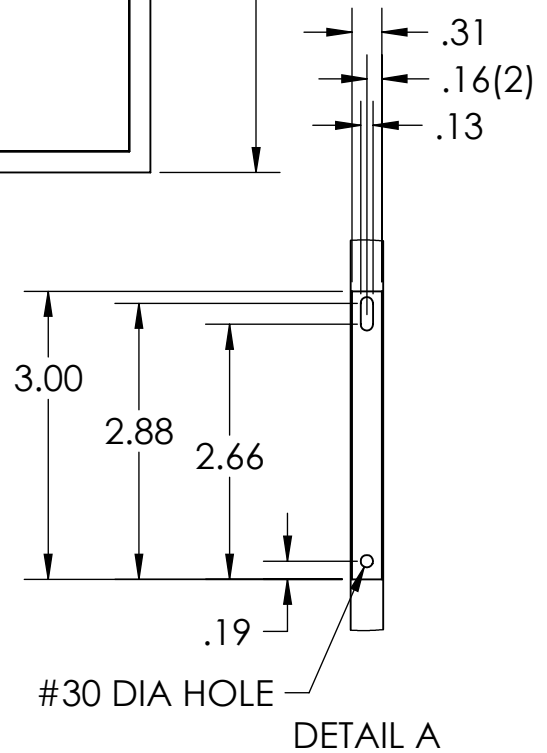

NOTES:

1. SEE SPECIFICATION SHEET P/N 89115124.
2. MATERIAL: .031 EXTRUDED POLYETHYLENE FLANGE +/- 1/32
3. PLASTIC PULL: RESEARCH PRODUCT #10-2452



PROPRIETARY AND CONFIDENTIAL

THE INFORMATION CONTAINED IN THIS DRAWING IS THE SOLE PROPERTY OF HOFFMAN ENCLOSURES. ANY REPRODUCTION IN PART OR AS A WHOLE WITHOUT THE WRITTEN PERMISSION OF HOFFMAN ENCLOSURES IS PROHIBITED.

PART NO. 89068420		E	UPDATE PART AND DRAWING.	ECO-163524	2/2/15	IJA				
MATERIAL SEE NOTES		REV.	DESCRIPTION	ECO/PDP	DATE	BY				
FINISH NA		 Pentair Technical Products 2100 Hoffman Way Anoka, Minnesota, 55303-7504, U.S.A. Phone(763)421-2240 Fax(763)421-1556								
TOLERANCE UNLESS NOTED							SCALE	NONE	TITLE <h1 style="text-align: center;">FILTER, AIR N28</h1>	
ONE PLACE (.X) ± .1							DRAWN	FHH		
TWO PLACE (.XX) ± .03							CHECKED	---		
THREE PLACE (.XXX) ± .015		APPROVED	---							
HOLE DIA ± .003		DATE	4/8/11	SIZE						
ANGLES ± 2°		DO NOT SCALE DRAWING		DRAWING NO. 89068420						
 THIRD ANGLE PROJECTION		SHEET 1 OF 1								