

THIS COPY IS PROVIDED ON A RESTRICTED BASIS AND IS NOT TO BE USED IN ANY WAY DETRIMENTAL TO THE INTERESTS OF PANDUIT CORP.

PART NO.	LABEL "A" +/- .062	LINER WIDTH "C" +/- .062	MATERIAL	ROLL LENGTH
T038X000C1C-BK	0.380 [9.7]	0.63 [16.0]	WHITE NYLON CLOTH	18'
T038X000C2C-BK	0.380 [9.7]	0.63 [16.0]	YELLOW NYLON CLOTH	18'
T050X000C1C-BK	0.500 [12.7]	0.85 [21.6]	WHITE NYLON CLOTH	18'
T050X000C2C-BK	0.500 [12.7]	0.85 [21.6]	YELLOW NYLON CLOTH	18'
T075X000C1C-BK	0.750 [19.1]	1.13 [28.7]	WHITE NYLON CLOTH	18'
T075X000C2C-BK	0.750 [19.1]	1.13 [28.7]	YELLOW NYLON CLOTH	18'
T100X000C1C-BK	1.000 [25.4]	1.13 [28.7]	WHITE NYLON CLOTH	18'
T100X000C2C-BK	1.000 [25.4]	1.13 [28.7]	YELLOW NYLON CLOTH	18'

NOTES:
1. MILLIMETER ARE IN [].

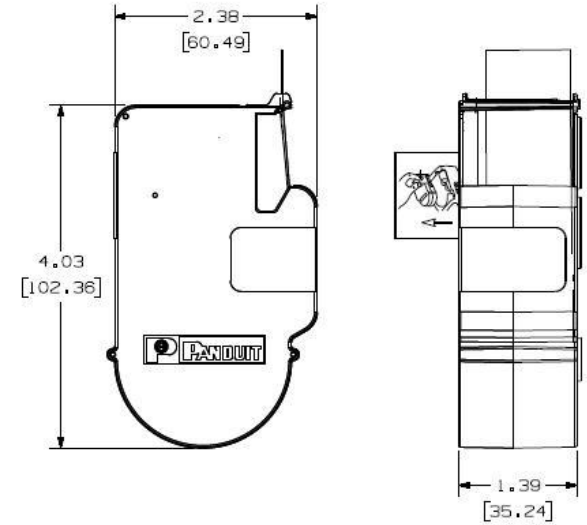
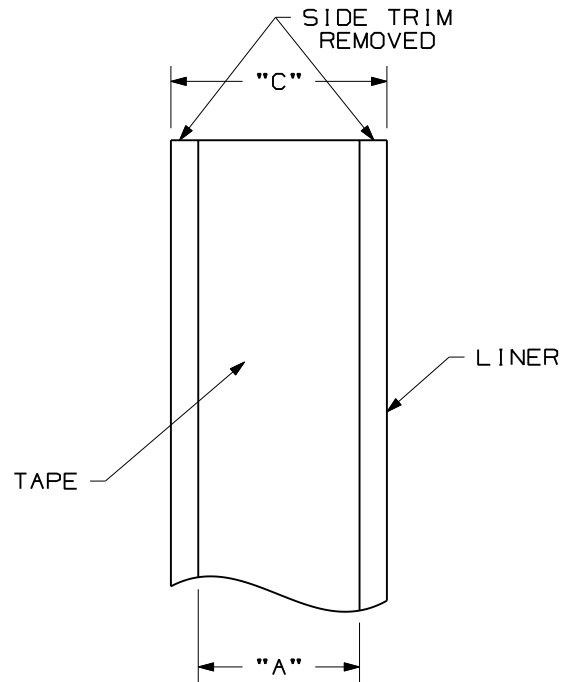

CAD FILENAME/LAYERS 100743SM_DC_C10748/01B

PANDUIT CORP. TINLEY PARK, ILLINOIS

CUSTOMER DRAWING
P1 CONTINUOUS
NYLON CLOTH TAPE

UNLESS OTHERWISE SPECIFIED,
DIMENSIONAL TOLERANCES ARE:
(.X) ± .12 (.XXX) ± .020
(.XX) ± .062 ANGLES ±

UNLESS OTHERWISE SPECIFIED,
ALL DIMENSIONS ARE GIVEN
IN INCHES, THIRD ANGLE PROJECTION.

1	5/12/09	RVU		ADD T038X000C1C-BK, T075X000C1C-BK, T038X000C2C-BK AND T075X000C2C-BK. INCORRECT TOLERANCES.	5926	R				DRAWN BY RVU	MAT'L: GMNYLC - 39W SEE TABLE	SCALE NTS	
0	10/17/08	RVU		DRAWING RELEASE.	5567	R			DATE 10/17/08			DRAWING NO. C10748	DWG A SIZE
REV	DATE	BY	CHK	DESCRIPTION	ECN	R	CUST	SUP	CHK'D				