

Opticom® Wall Mount Enclosures

specifications

Wall mount enclosures shall be constructed of steel material. Enclosures shall provide cable bend radius protection. Enclosures offer optional discrete locking capability between service and user segments.



technical information

Dimensions:	FWME2: WxHxD=12 x 10.18 x 2.32 in. (304.8 x 258.6 x 59.1mm) FWME4: WxHxD=16.11 x 12.25 x 3.52 in. (409.2 x 311.0 x 89.4mm) FWME8: WxHxD=16.11 x 20.25 x 3.52 in. (409.2 x 514.2 x 89.4mm)
Splicing tray and holder capacity:	FWME2: Holds (1) FSTHS which accommodates up to (2) FSTK FWME4: Holds (1) FST6H4 which accommodates up to (4) FST6 FWME8: Holds (2) FST6H4 which accommodates up to (4) FST6 each
HD Flex™ Cassette and holder capacity:	FWME2: Not usable FWME4: Holds (4) FLEX-OPTI-1RU holders which accommodates (2) HD Flex™ cassettes each FWME8: Holds (8) FLEX-OPTI-1RU holders which accommodates (2) HD Flex™ cassettes each
Packaging:	Includes accessory kit and labels

key features and benefits

Improved strain relief clip	Easier to install and align fiber with grommet
Spooling area	Manages and organizes fiber slack
Rubber grommet	Offers dust/debris protection and helps secure cable to enclosure
Improved latch	Provides improved closure
Optional keyed lock	Provides added security
Works with most Mini-Com® LC, SC, and ST modules and Opticom®, HD Flex™ cassettes	Offers flexibility for a variety of applications
Flush mounted latch	Minimizes box depth from wall
Optional splicing tray and holder	Allows splicing within patching enclosures

applications

Opticom® Wall Mount Enclosures are designed to manage and organize fiber distribution in areas where space is limited. They can also be used to manage cable from outside the facility. Enclosures can be used as an interconnect or cross-connect in any

telecommunications room and can use any standard FAP or FMP series adapter panel. Opticom® Enclosures are completely modular and can manage both fiber and copper cables.

Opticom® Wall Mount Enclosures

Max 48 fibers (2 FAP):	FWME2
Max 24 fibers (2 FSTK):	
Max 96 fibers (4 FAP):	FWME4
Max 48 fibers (4 FST6):	
Max 192 fibers (8 FAP):	FWME8
Max 96 fibers (8 FST6):	

Adapter Panels

Blank panel:	FAPB
---------------------	------

LC Adapter Panels

6 duplex LC:	FAP6WAQDLCZ
12 duplex LC:	FAP12WAQDLCZ

SC Adapter Panels

3 duplex SC:	FAP3WBUDSCZ
6 duplex SC:	FAP6WBUDSCZ

Splice Tray

FWME4, FWME8	
Holder:	FST6H4
Splice tray:	FST6

FWME2	
Holder:	FSTHS
Splice tray:	FSTK

Door Locks

User side:	FELU
Service side:	FELS

Wall Mount Enclosures

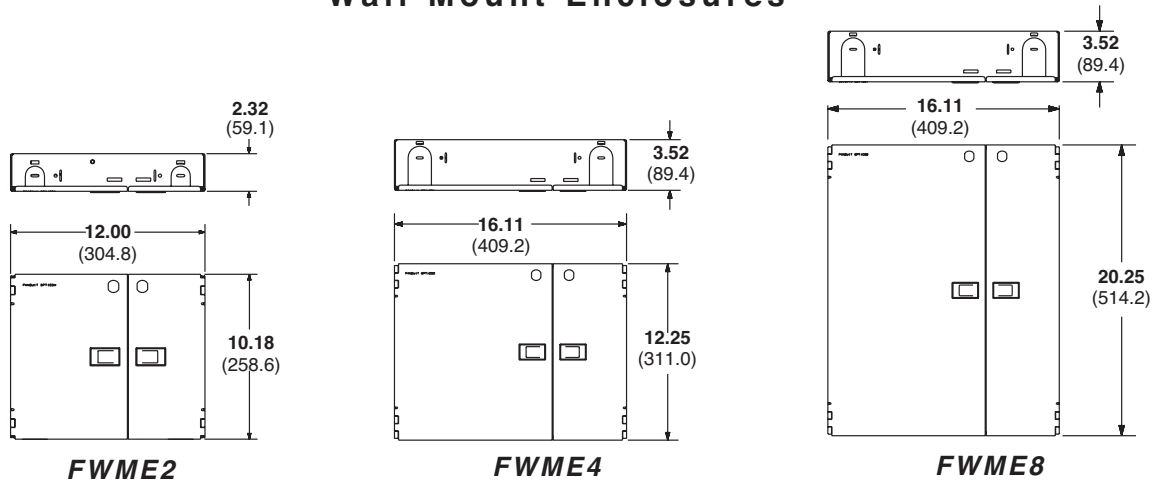

Adapter Panels



Splice Trays

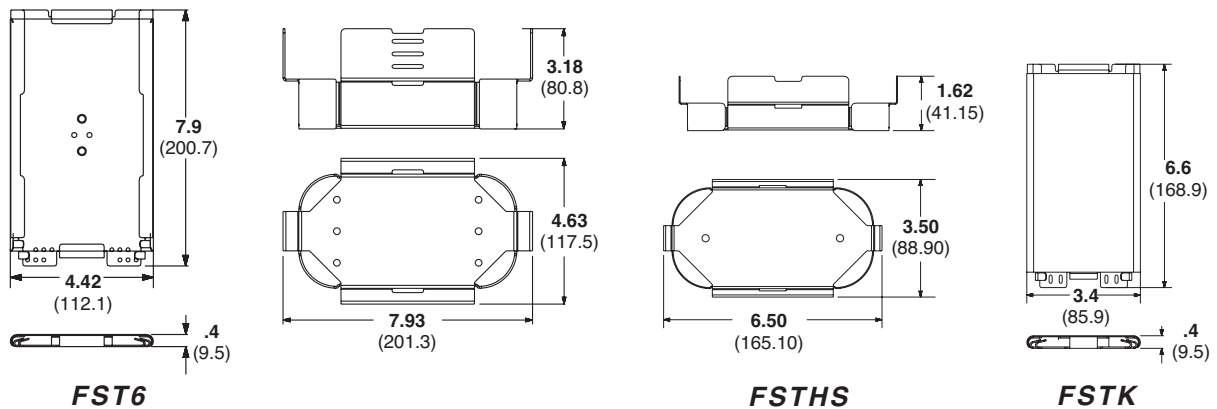

Dimensions are in inches. (Dimensions in parenthesis are metric).

WORLDWIDE SUBSIDIARIES AND SALES OFFICES

PANDUIT US/CANADA
 Phone: 800.777.3300

PANDUIT EUROPE LTD.
 London, UK
 Phone: 44.20.8601.7200

PANDUIT SINGAPORE PTE. LTD.
 Republic of Singapore
 Phone: 65.6305.7575

PANDUIT JAPAN
 Tokyo, Japan
 Phone: 81.3.6863.6000

PANDUIT LATIN AMERICA
 Guadalajara, Mexico
 Phone: 52.33.3777.6000

PANDUIT AUSTRALIA PTY. LTD.
 Victoria, Australia
 Phone: 61.3.9794.9020

For a copy of Panduit product warranties, log on to www.panduit.com/warranty



For more information
Visit us at www.panduit.com
 Contact Customer Service by email: cs@panduit.com
 or by phone: 800.777.3300

© 2021 Panduit Corp.
 ALL RIGHTS RESERVED.
 FBSP108--WW-ENG
 5/2021