

SmartStruxure™ Lite Solution

Suitcase (SSL-CASE)

The suitcase is the ideal demo tool for the SmartStruxure Lite solution. It covers a wide range of applications, and segment specific visualisations.



Get Control. Get Efficient. Get Value.

SmartStruxure Lite solution Suitcase Features



The suitcase enables you to demo the SmartStruxure Lite solution using fully mounted products and uploadable pre-programmed Building Expert databases.

SmartStruxure Lite solution to go

The suitcase is perfect for tradeshows, as well as meetings with end-customers, engineering firms, partners and branches. The suitcase is easy to carry, with luggage-style wheels and telescopic handle.

Demo applications

The suitcase includes demonstrations for multiple applications, including:

- HVAC control with the SE8000
- Lighting control with an EnOcean light switch and light relay
- Lux level sensing with the SE8000
- Occupancy detection with the SE8000's PIR motion sensor, and with an SED-WDS-P ZigBee Pro door & window contact switch
- Energy metering simulated through the MPM
- Comfort and energy efficiency automation based on schedule and occupancy events

Demo visualisations

After upload and commissioning of the suitcase database, Building Expert offers multiple visualizations of applications, through Dashboards and Section maps, for multiple segments, including:

- Education
- Healthcare
- Hotels
- Offices
- Retail

Commissioning

Upon reception, the suitcase requires commissioning before being ready to demo.

Commissioning includes:

- Download of the Suitcase commissioning demo tool (The Exchange)
- Upload of database, configuration, and images, to the MPM
- Upload of Lua4RC script and standby image to the SE8000
- Pairing of ZigBee Pro and EnOcean devices



AT A GLANCE

Software

- StruxureWare™ Building Expert

Multi-Purpose Management devices (MPM)

- MPM-UN

Room Controllers

- SE8000 with PIR motion sensor for HVAC applications, occupancy detection, and ambient lux level readings

End-devices

- ZigBee Pro door & window contact switch for occupancy applications
- EnOcean (902MHz or 868MHz) devices for lighting control applications

Lighting

- LED strip

Connectivity to PC/Laptop

- Ethernet cable and Wi-Fi connection to the suitcase's router

Accessories

- Ethernet cable
- USB to micro USB cable
- Universal travel adaptor (model dependent)

SmartStruxure Lite solution Suitcase Features

Suitcase contents

The suitcase contains all components necessary for use.

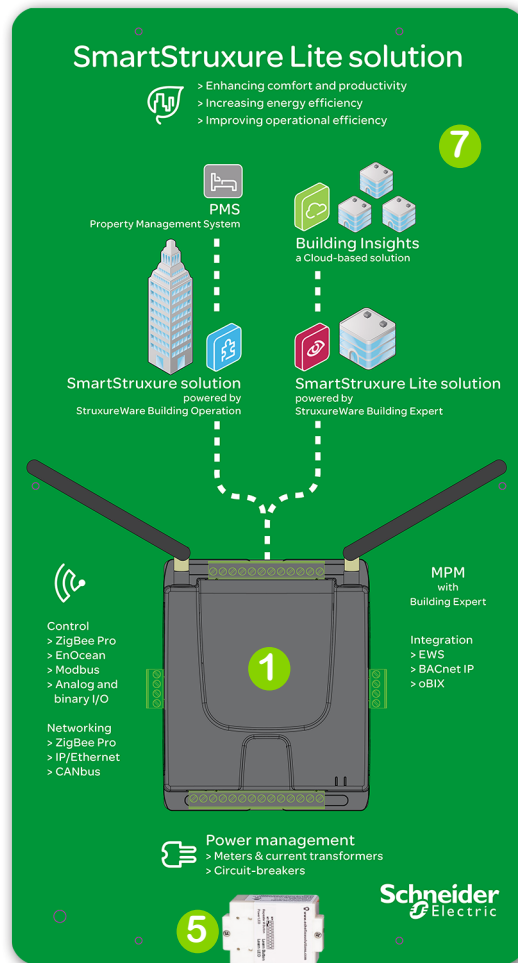

Mounted products

- MPM-UN
 - NAM/LAM (902MHz): MPM-UN-EI4-5045
 - EMEA/APAC (868MHz): MPM-UN-DI4-5045
- SE8350U5B11 for fan coils and zone control, with VCM8000V5045P ZigBee Pro communication module.
- SED-WDS-P-5045 ZigBee Pro door & window contact.
- EnOcean light switch
 - NAM/LAM (902MHz): SED-1RS-U-5045
 - EMEA/APAC (868MHz): LSS10020049
- EnOcean light relay (model specific to the suitcase to provide power to the LED light)
 - NAM/LAM (902MHz)
 - EMEA/APAC (868MHz)
- LED light strip
- Wi-Fi router (hidden under right side panel)

Accessories

- Ethernet cable (5ft Cat6 flat/slim)
- USB to micro USB cable (6ft flat/slim)
- EMEA/APAC model only: Universal travel adaptor (Schneider Electric branded)
- Commissioning instructions



SmartStruxure Lite solution Suitcase Specifications

Specifications

SSL-CASE

Dimensions

559mm (L) x 356mm (W) x 229mm (H)

22.0in (L) x 14.0in (W) x 9.0in (H)

Power Requirements

110V-240V

Operating Conditions

0 °C - 50 °C (32 °F - 122 °F)

0% - 95% R.H. non-condensing

Storage Conditions

-30 °C - 50 °C (-22 °F - 122 °F)

0% - 95% R.H. non-condensing

THE SUITCASE IS A DEMONSTRATION PRODUCT AND IS TO BE ONLY USED FOR DEMONSTRATION PURPOSES.

FOR SPECIFICATIONS AND CERTIFICATIONS OF THE INDIVIDUAL PRODUCTS MOUNTED IN THE SUITCASE, CONSULT THEIR RESPECTIVE SPECIFICATIONS DOCUMENTATION"

Dimensions

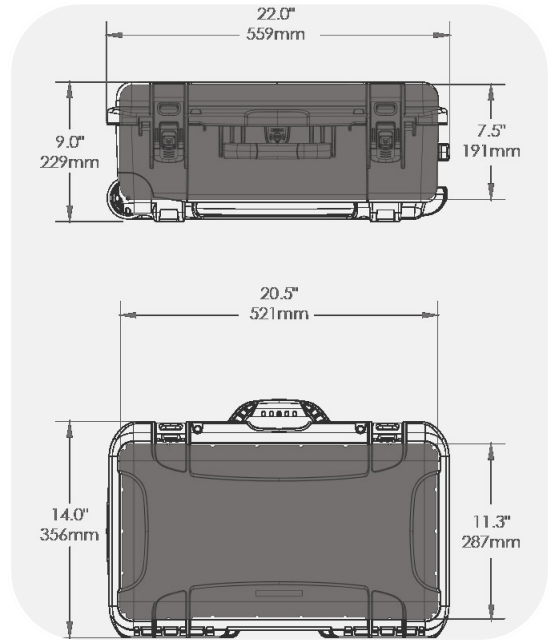

Part numbers

SSL-CASE

part numbers

Description

EnOcean frequency

Region

SSL-CASE-EI4-BE1

SmartStruxure Lite suitcase: MPM-UN, SE8300, ZigBee Pro door-window switch, 2 EnOcean 902MHz

902MHz

NAM/LAM

SSL-CASE-DI4-BE2

SmartStruxure Lite suitcase: MPM-UN, SE8300, ZigBee Pro door-window switch, 2 EnOcean 868MHz

868MHz

EMEA/APAC

All brand names, trademarks and registered trademarks are the property of their respective owners. Information contained within this document is subject to change without notice.